

ACCESSORIES
Model WDG1R
Table Top Wedge Mount

The WDG1R is a tabletop enclosure for mounting any RACK-UP module. All steel construction.



Front



Rear



With Product Installed
(RU-SH1 available separately)

ACCESSORIES
Model WDG1R
Table Top Wedge Mount

Installation/Operation



EN55103-1 E1-E5; EN55103-2 E1-E4
Typical Performance reflects product at publication time exclusive of EMC data, if any, supplied with product. Specifications are subject to change without notice.

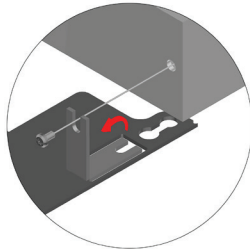

NOTE: When installing a RACK UP product that is in a plastic box start by removing the screws from the back of the RACK UP. Bend the tabs on the mounting unit up at a 90° angle. Secure the unit to the mounting chassis using the screws. Continue to Step 3.

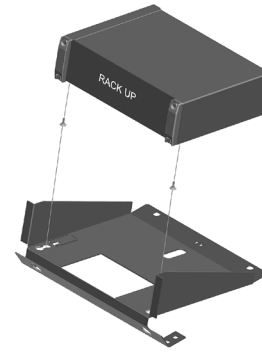

STEP #1

Start the screws into the bottom of the RACK-UP but do not install them all the way. Place the RACK-UP onto the chassis. The screw heads will pass through the rear position in the cutout.

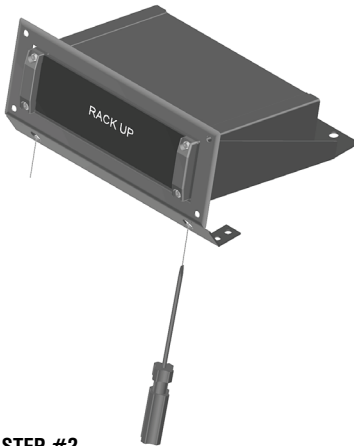

STEP #2

Slide the unit forward until the screws are seated in the forward position of the cutout. Tighten the screws to secure the unit in the chassis.

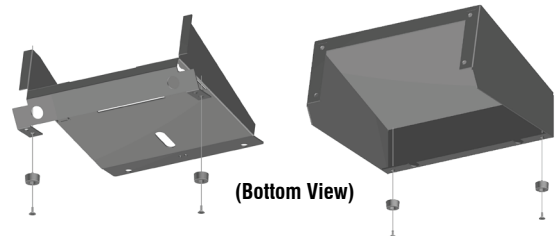

NOTE: If the unit will not be permanently mounted to a surface skip Step 3. Instead install the included feet using the 6-32 screws. Install the feet in the locations shown on the above drawing. Continue to Step 4.

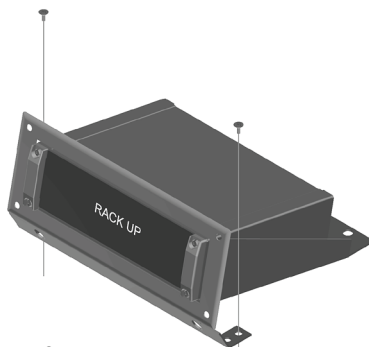

STEP #3

Secure the chassis to the mounting surface with screws. (Screws not included)

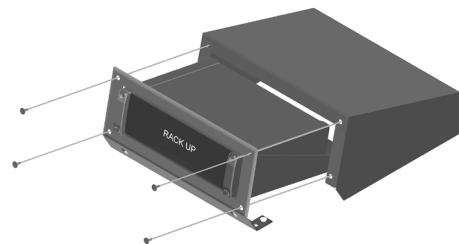

STEP #4

Slide the top cover toward the chassis. Once seated secure the top cover to the chassis with the four included screws.