

VGA KVM | Over IP

EXT-VGAKVM-LAN

User Manual
Release A5



Important Safety Instructions

GENERAL SAFETY INFORMATION

1. Read these instructions.
2. Keep these instructions.
3. Heed all warnings.
4. Follow all instructions.
5. Do not use this product near water.
6. Clean only with a dry cloth.
7. Do not block any ventilation openings. Install in accordance with the manufacturer's instructions.
8. Do not install or place this product near any heat sources such as radiators, heat registers, stoves, or other apparatus (including amplifiers) that produce heat.
9. Do not defeat the safety purpose of the polarized or grounding-type plug. A polarized plug has two blades with one wider than the other. A grounding type plug has two blades and a third grounding prong. The wide blade or the third prong are provided for your safety. If the provided plug does not fit into your outlet, consult an electrician for replacement of the obsolete outlet.
10. Protect the power cord from being walked on or pinched particularly at plugs, convenience receptacles, and the point where they exit from the apparatus.
11. Only use attachments/accessories specified by the manufacturer.
12. To reduce the risk of electric shock and/or damage to this product, never handle or touch this unit or power cord if your hands are wet or damp. Do not expose this product to rain or moisture.
13. Unplug this apparatus during lightning storms or when unused for long periods of time.
14. Refer all servicing to qualified service personnel. Servicing is required when the apparatus has been damaged in any way, such as power-supply cord or plug is damaged, liquid has been spilled or objects have fallen into the apparatus, the apparatus has been exposed to rain or moisture, does not operate normally, or has been dropped.
15. Batteries that may be included with this product and/or accessories should never be exposed to open flame or excessive heat. Always dispose of used batteries according to the instructions.

Warranty Information

Gefen warrants the equipment it manufactures to be free from defects in material and workmanship.

If equipment fails because of such defects and Gefen is notified within two (2) years from the date of shipment, Gefen will, at its option, repair or replace the equipment, provided that the equipment has not been subjected to mechanical, electrical, or other abuse or modifications. Equipment that fails under conditions other than those covered will be repaired at the current price of parts and labor in effect at the time of repair. Such repairs are warranted for ninety (90) days from the day of reshipment to the Buyer.

This warranty is in lieu of all other warranties expressed or implied, including without limitation, any implied warranty or merchantability or fitness for any particular purpose, all of which are expressly disclaimed.

1. Proof of sale may be required in order to claim warranty.
2. Customers outside the US are responsible for shipping charges to and from Gefen.
3. Copper cables are limited to a 30 day warranty and cables must be in their original condition.

The information in this manual has been carefully checked and is believed to be accurate. However, Gefen assumes no responsibility for any inaccuracies that may be contained in this manual. In no event will Gefen be liable for direct, indirect, special, incidental, or consequential damages resulting from any defect or omission in this manual, even if advised of the possibility of such damages. The technical information contained herein regarding the features and specifications is subject to change without notice.

For the latest warranty coverage information, refer to the Warranty and Return Policy under the Support section of the Gefen Web site at www.gefen.com.

PRODUCT REGISTRATION

Please register your product online by visiting the Register Product page under the Support section of the Gefen Web site.

Contacting Gefen Technical Support

Gefen, LLC
c/o Customer Service
20600 Nordhoff St.
Chatsworth, CA 91311

Telephone: (818) 772-9100
(800) 545-6900

Fax: (818) 772-9120

Email: support@gefen.com

Visit us on the Web: www.gefen.com

Technical Support Hours: 8:00 AM to 5:00 PM Monday - Friday, Pacific Time

VGA KVM over IP is a trademark of Gefen, LLC.

Important Notice

Gefen, LLC reserves the right to make changes in the hardware, packaging, and any accompanying documentation without prior written notice.

Operating Notes

- The VGA KVM over IP is compatible with the DVI KVM over IP and the HD KVM over IP, which allows these products to be connected within a single system. Note that HDCP content cannot be used when using these products in tandem.
- CAT-5 or CAT-6 cables should not exceed 330 feet (100 meters) between the Sender / Receiver unit and the network.
- By default, all Sender and Receiver units are set to channel 0.
- This product does **not** support HDCP or dual link resolutions.
- By default, the source device will use the EDID from the display (or other sink device) which is connected the Receiver unit. See [EDID Management](#) for more information.
- If terminating network cables in the field, please adhere to the TIA/EIA568B specification. See the [Network Cable Diagram](#) for details.



IMPORTANT: The use of a Gigabit switch with 8K “jumbo frame” capability is required when connecting the VGA KVM over IP to a network.

The following table (continued on next page) details the IP and IP port use of the VGA KVM over IP. Each “X” in the table, below, represents that no specified IP port is required.

	Type	Sender ↔ Receiver	Description
Link Manager	TCP	6751 ← X	msg_channel, ast_heartbeat
	UDP / MC	X → 3246	ast_heartbeat multicast port Use the “multicast stream” multicast IP
	UDP / MC	3333 → 3334 3334 ← 3333	“Name Service” Use 225.1.0.0 multicast IP 3333 listen for query; 3334 for reply
	Type	Sender ↔ Receiver	Description
Video over IP	UDP / MC	3344 ← X	control channel
	TCP	3344 ← X	control channel
	TCP	3240 ← X	TCP unicast mode only
	UDP	X → 3245	UDP unicast mode only (unicast mode default mode uses UDP, not TCP)
	UDP / MC	X → 3245	multicast mode only

	Type	Sender ↔ Receiver	Description
i2S over IP	TCP	1234 ↔ X	control channel
	UDP / MC	X → 1235	data streaming for both unicast and multicast mode
	Type	Sender ↔ Receiver	Description
USB over IP	TCP	6000 ↔ X	USB over IP data
	TCP	6755 ↔ X	vhub_heartbeat USB over IP-specific
	Type	Sender ↔ Receiver	Description
Serial over IP	TCP	X → 6752	type 1
	TCP	6752 ↔ X	type 2
	Type	Sender ↔ Receiver	Description
IR over IP	TCP	18771 ↔ X	upstream IR over IP data
	UDP / MC	X → 18770	downstream IR over IP data
	TCP	18770 ↔ X	IR over IP data (TCP unicast mode only)

Features and Packing List

Features

- Extends VGA, USB, RS-232, bi-directional stereo analog audio, and IR over IP, using a Gigabit Local Area Network
- Any combination of HDMI, DVI, and VGA Senders and Receivers can be used
- Supports resolutions up to 1920 x 1200 (WUXGA)
- Built-in Web interface for each Sender and Receiver unit provides intuitive control of all features
- Supports 256 Senders and a total of just over 65,000 Receiver units, depending on the network bandwidth and number of ports of your network switch
- USB 2.0 data rates up to 480 Mbps and backward-compatibility with USB 1.1
- Three-port Gigabit Ethernet switch built into the Receiver unit
- Switch between all available Sender units using the built-in Web interface
- Mode button on Sender for sharpness or motion optimization of image
- Field-upgradable firmware via web server interface
- Locking power supply connectors
- 1U tall, half-rack width enclosures are rack-mountable using EXT-RACK-1U
- Surface mounting brackets included

Packing List

The *VGA KVM over IP* ships with the items listed below. If any of these items are not present in the box when you first open it, immediately contact your dealer or Gefen.

- 1 x VGA KVM over IP (Sender unit)
- 1 x VGA KVM over IP (Receiver unit)
- 1 x 6 ft. VGA cable (M-M)
- 1 x 6 ft. USB cable (A-B)
- 1 x 6 ft. DB-9 cable (M-F)
- 2 x Mounting rack with screws
- 2 x 5V DC power supplies
- 1 x Quick-Start Guide

Table of Contents

01 Getting Started

Sender Unit Layout.....	2
Front.....	2
Back.....	3
Receiver Unit Layout.....	4
Front.....	4
Back.....	5
Installation.....	6
Using a Direct Connection.....	6
Local Area Network (LAN) Connection.....	8
Supplementary Connections.....	10
Sample Wiring Diagram.....	11

02 Operating the VGA KVM over IP

Basic Operation.....	14
Displaying the IP Address.....	14
Setting the IP Mode.....	17
Setting the Video Channel.....	18
Enabling or Disabling Video over IP.....	19
Unicast and Multicast Modes.....	20
Configuring Unicast Mode.....	20
Switching between Sender units in Unicast mode.....	22
Configuring Multicast Mode.....	25
Using RS-232.....	27
RS-232 under Unicast Mode.....	29
RS-232 under Multicast Mode.....	29
USB Control.....	30
USB under Unicast Mode.....	30
USB under Multicast Mode.....	32
EDID Management.....	36
Using the Internal VGA EDID.....	36
Using the Downstream EDID.....	37
Audio Connections.....	38
Using VGA Sources.....	40
Setting the Video Mode.....	41
Performing a Factory Reset.....	42
Sender Unit.....	42
Receiver Unit.....	42

03 Appendix

Upgrading the Firmware.....	45
17 Channels or Less	47
Developer Notes.....	49
Network Cable Diagram	50
Rack Tray Installation	51
Specifications	52

VGA | Over KVM | IP

01 Getting Started

Sender Unit Layout

Front



ID	Name	Description
1	Power	This LED glows steady blue when the unit is connected to an AC outlet and the unit is powered ON.
2	Link	This LED glows steady green when the Sender unit and Receiver unit are connected and passing video.
3	Mode	Press this button to switch between Graphic Mode and Video Mode. Graphic Mode optimizes still images. Video Mode is best used for optimizing video. See Setting the Video Mode for details.
4	Reset	Press this button to reset the unit. See Performing a Factory Reset for instructions on restoring the Sender unit to factory-default settings.

Back

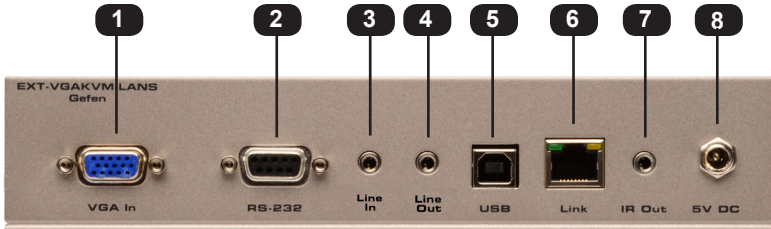

ID	Name	Description
1	VGA In	Connect the included VGA cable from this connector to the VGA source.
2	RS-232	Connect the included RS-232 cable from this port to an RS-232 device. See Using RS-232 for details.
4	Line In	Connect a 3.5mm mini-stereo cable from the Line Out jack on the multimedia PC to this jack.
5	USB	Connect a USB cable from the computer to this USB port.
4	Line Out	Connect a 3.5mm mini-stereo cable from this jack to the Line In jack of a multimedia PC.
6	LAN	Connects the Sender unit to the network (or directly to the Receiver unit) using an Ethernet cable.
7	IR Out	Connect an IR Blaster cable (Gefen part no. EXT-2IREMIT) from this jack to the VGA source to control the source from the viewing location.
8	5V DC	Connect the included 5V DC locking power supply to this power receptacle.

Receiver Unit Layout

Front



ID	Name	Description
1	Power	This LED glows steady blue when the unit is connected to an AC outlet and the unit is powered ON.
2	Link	This LED glows steady green when the Sender and Receiver units are connected using Ethernet cable and successfully passing video.
3	IR	This IR sensor receives signals from the source IR remote control.
4	Reset	Press this button to reset the unit. See Performing a Factory Reset for instructions on restoring the Receiver unit to factory-default settings.
5	Switch	Switches the video channel when using multiple Receiver units on a network. See Setting the Video Channel for details.
6	Mic In	Connect a microphone to this jack. If the microphone has a 1/4" jack, use a 1/4"-to-3.5mm adapter to connect the microphone to the Receiver unit.
7	Line Out	Connect a 3.5mm mini-stereo cable from this jack to a pair of powered speakers. See Audio Connections for details on connecting audio source and speakers.
8	USB	Connect up two USB devices to these USB ports.

Back

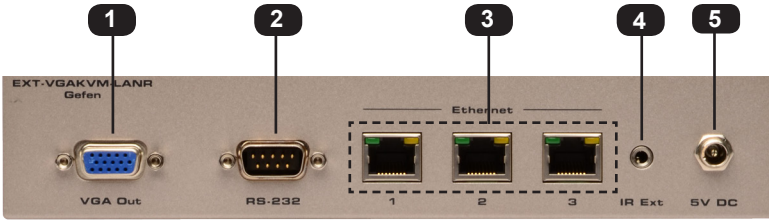

ID	Name	Description
1	VGA Out	Connect an VGA cable from this connector to the VGA display.
2	RS-232	Connect the included RS-232 cable from this port to an RS-232 device. See Using RS-232 for details.
3	LAN	Connects the Receiver unit to the network (or directly to the Sender unit) using an Ethernet cable. See the next page for installation instructions.
4	IR Ext	Connect an IR Extender cable (Gefen part no. EXT-RMT-EXTIRC or EXT-RMT-EXTIRN) to this port.
4	5V DC	Connect the included 5V DC locking power supply to this power receptacle.

Installation

The *VGA KVM over IP* Sender and Receiver units can either be connected over a Local Area Network (LAN) or they can be directly connected to one another.

Using a Direct Connection

By default, the *VGA KVM over IP* is shipped in *Auto IP* mode. In *Auto IP* mode, each Sender and Receiver unit assigns itself a unique IP address within the range of 169.254.x.x. *Auto IP* mode is only used when Sender and Receiver units are directly connected to one another. When connecting to a network, the *VGA KVM over IP* must be set to *DHCP* mode or *Static IP* mode. See [Setting the IP Mode](#) for more information.

1. Connect a CAT-5e (or better) cable from the **LAN** port on the Sender unit to the **LAN 1** port on the Receiver unit.

Figure 1.1 - Directly connecting the Sender and Receiver unit

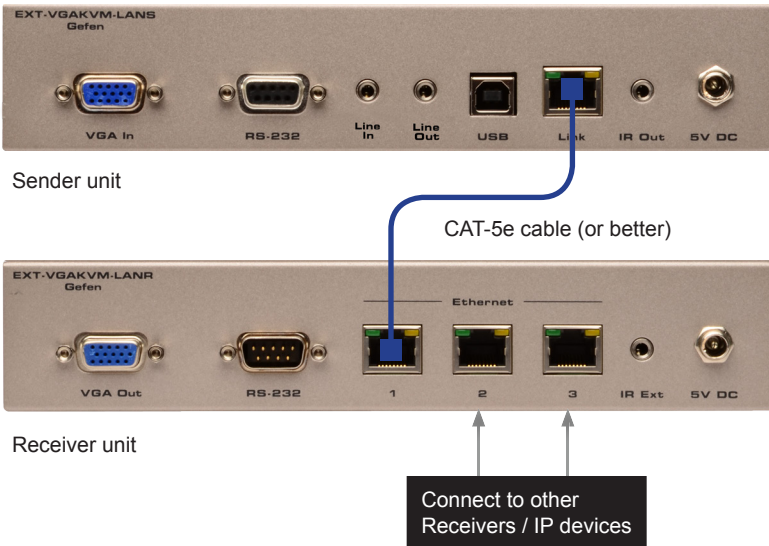

Although any **LAN** port on the Receiver unit can be used, using the **LAN 1** port makes it easy to identify which Ethernet cable is used to connect the Sender and Receiver unit. **LAN 2** and **LAN 3** ports can then be used for connecting additional devices or when daisy-chaining Receiver units.

2. Use the included VGA cable to connect the VGA source to the **VGA In** port on the Sender unit.
3. Connect a VGA cable from the VGA display to the **VGA Out** port on the Receiver unit.

4. See [Supplementary Connections](#) for instruction on connecting USB, IR, RS-232, and audio cables.
5. Connect the included 5V DC locking power supplies to the Sender unit and Receiver unit. Do not overtighten the locking connectors. Connect the included AC power cords from the power supplies to available electrical outlets.
6. After a few moments, the VGA source will be displayed.

Local Area Network (LAN) Connection



IMPORTANT: The use of a Gigabit switch with 8K "jumbo frame" capability is *required* when connecting the VGA KVM over IP to a network.

In order to connect the *VGA KVM over IP* to a Local Area Network (LAN), both the Sender and Receiver unit must first be set to *DHCP* mode or *static IP* mode. *DHCP* mode will use the DHCP server to automatically assign an IP address for each Sender and Receiver unit that is connected to the network. *Static IP* mode will allow the IP address for each Sender and Receiver unit to be configured manually. Contact your network administrator if necessary.

1. Follow the connection steps under [Using a Direct Connection](#).
2. Connect an Ethernet cable from one of the **LAN** ports on the Receiver unit to the network.

If *DHCP* mode will be used, connect the Receiver unit to a DHCP server.

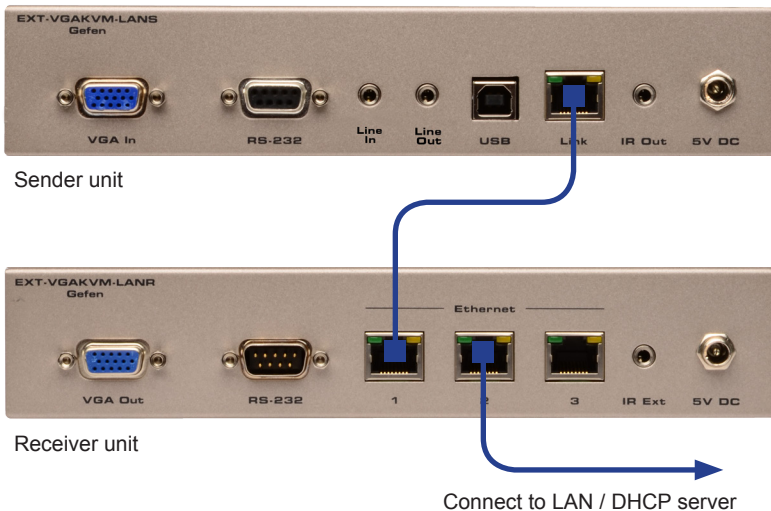

3. Access the Web interface for the Sender unit by entering its IP address in the address bar of the Web browser. If the IP address is not known, see [Displaying the IP Address](#)
4. Set the VGA KVM over IP to the desired network mode (DHCP or static). Refer to [Setting the IP Mode](#) for instructions on setting the network mode.
5. Repeat steps 3 and 4 for the Receiver unit.

6. Disconnect the cable between the Sender and Receiver unit.
7. Connect the cable from the Sender unit to the network.



Sender unit

←
Connect to LAN

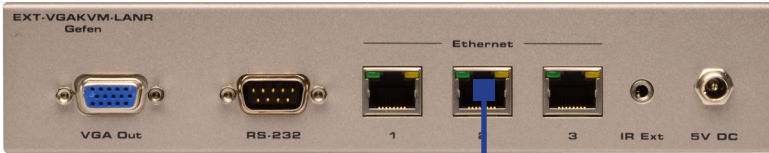

Receiver unit

←
Connect to LAN / DHCP server

Note that any **LAN** port on the Receiver unit can be used to connect to the LAN.

Supplementary Connections

► **USB (see [USB Control](#) for more information on using USB devices)**

1. Connect a USB cable from the computer to the **USB** port on the Sender unit.
2. Connect up to two USB devices to the Receiver unit.

► **IR**

3. Connect a Gefen IR Emitter (Gefen part no. EXT-2IREMIT) to the Sender unit and attach it to the IR sensor on the device to be controlled.
4. Connect an IR Extender (Gefen part no. EXT-RMT-EXTIRC or EXT-RMT-EXTIRN) to the Receiver unit if the IR sensor will not be within line-of-site for proper IR control.

► **Audio (see [Audio Connections](#) for more information on using audio devices)**

7. Connect a 3.5mm mini-stereo cable from the **Line In** jack on the Sender unit to an audio source.
8. Connect a pair of powered speakers (or another audio output device) to the **Line Out** jack on the Receiver unit.
9. Connect a microphone to the Mic In jack on the Receiver unit.
10. Connect a pair of powered speakers (or another audio output device) to the **Line Out** jack on the Sender unit.

► **RS-232**

11. Connect the included RS-232 cable from the PC or automation system to the **RS-232** port on the Sender unit.
12. Connect an RS-232 cable from the Receiver unit to the RS-232 device to be controlled.

Sample Wiring Diagram

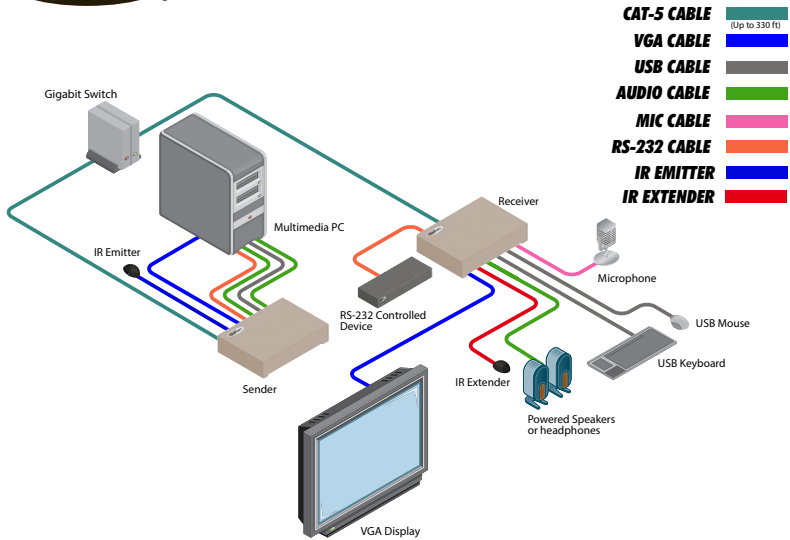
**EXT-VGAKVM-LAN**

VGA | **Over** **KVM** | **IP**

02 Operating the VGA KVM over IP

Basic Operation

Displaying the IP Address

If the IP address(es) of a Sender and/or Receiver unit are not known, then use the following procedure to display the IP address of any Sender or Receiver unit on the network.

1. Press and release the **Switch** button on the front panel of the Receiver unit. The current video channel will be displayed in the top-left corner of the screen.



In the example, above, the current video channel is set to 0.

2. Change the video channel number by pressing and releasing the **Switch** button to advance to the next video channel. Video channel numbers range from 0 to 255. Consecutively pressing the **Switch** button will cycle through all 256 channels.



3. After a few moments, the screen will go blank and the IP address of both the Sender and Receiver unit will be displayed in the lower-right corner of the screen.

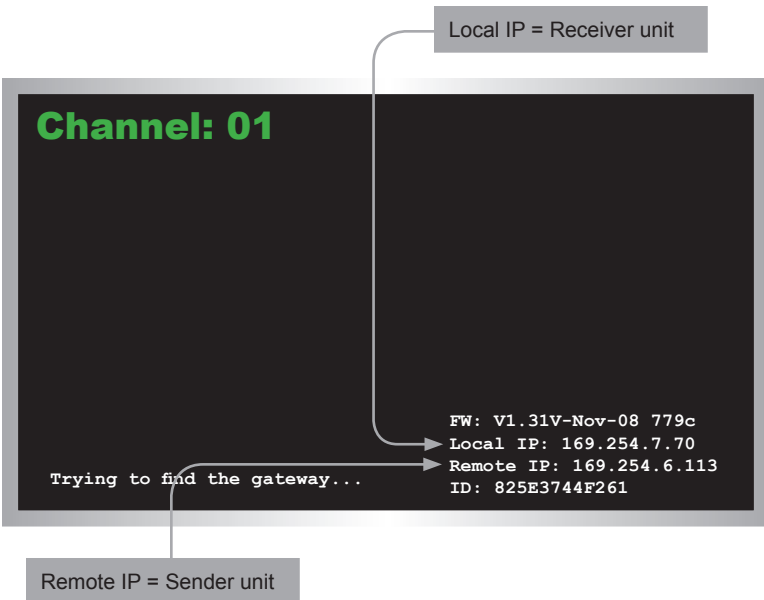

4. In order to return to the original video channel (without cycling through all 255 channels), access the Web interface for the Receiver unit. Refer to [Setting the Video Channel](#) for more information.

5. To upgrade the firmware to a limited number of channels, refer to [Upgrading the Firmware](#) for more information.

Setting the IP Mode

The VGA KVM over IP can be set to *Auto IP*, *DHCP*, or *Static IP* mode. By default, the VGA KVM over IP is shipped in *Auto IP* mode.

1. Access the Web interface by entering the IP address of the desired Sender or Receiver unit. Refer to [Displaying the IP Address](#) if necessary.
2. Click the **Network** tab. The current IP Mode will be highlighted within the **IP Setup** window group. In the illustration below, *Auto IP* button is highlighted.

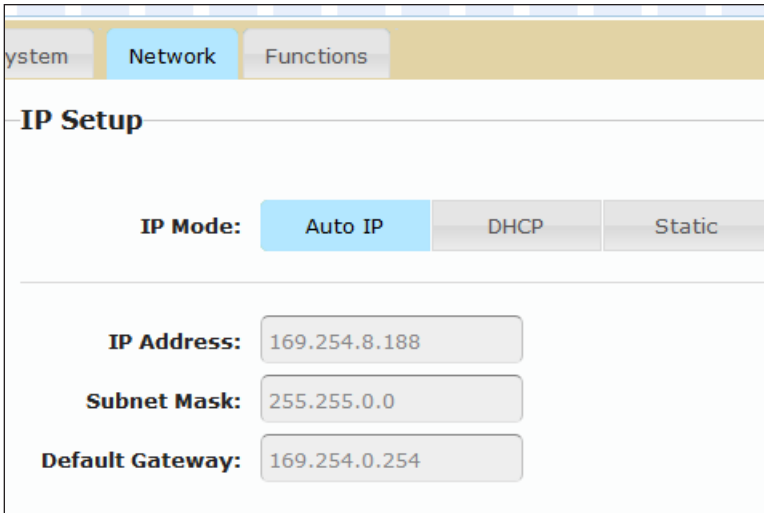

The screenshot shows a web interface with three tabs: 'System', 'Network', and 'Functions'. The 'Network' tab is selected and highlighted in blue. Below the tabs is the 'IP Setup' section. Under 'IP Mode', there are three buttons: 'Auto IP' (highlighted in blue), 'DHCP', and 'Static'. Below this, there are three input fields: 'IP Address' with the value '169.254.8.188', 'Subnet Mask' with the value '255.255.0.0', and 'Default Gateway' with the value '169.254.0.254'.

3. Click the desired IP Mode button.
4. Click the **Save** button on the right-hand side of **IP Setup** window group.
5. Click the **Reboot** button near the bottom of the page.
6. Access the Web interface for the Receiver unit by entering its IP address.
7. Repeat steps 2 - 5 for each Sender and Receiver to be changed.

Setting the Video Channel

In order a Sender and Receiver unit to communicate with one another, they must both be set to the same channel. This is similar to changing the channel on a cable or satellite box in order to view a different program. By default, all Sender and Receiver units are set to channel 0.



NOTE: When connecting Sender and Receiver units, it is highly recommend that the video channel for each unit is set to a channel other than 0. This will allow for the addition of future Sender and/or Receiver units without causing video channel conflicts.

1. Access the Web interface by entering the IP address of the desired Sender or Receiver unit. Refer to [Displaying the IP Address](#) if necessary.
2. Click the **Network** tab. The current channel is displayed within the **Network Mode** window group.
3. Click the **Channel Selection** drop-down list and select the desired channel. Channel numbers can range from 0 to 255.

The screenshot shows a web interface with two main sections: 'Network Mode' and 'Channel Setup'. In the 'Network Mode' section, there are two tabs: 'Multicast' and 'Unicast', with 'Unicast' being the active tab. A 'Save' button is located on the right side of this section. The 'Channel Setup' section contains a 'Channel Selection' dropdown menu currently showing '1'. A mouse cursor is pointing at the dropdown arrow. A 'Save' button is also present at the bottom right of the 'Channel Setup' section.

4. Click the **Save** button on the right-hand side of **Network Mode** window group.
5. The following message will be displayed, at the top of the page, indicating that the casting mode has been applied to the Sender or Receiver unit.

Success: New casting mode applied.

6. Access the Web interface of the next unit (Sender or Receiver) by entering its IP address.
7. Repeat steps 2 - 5 for each Sender and Receiver to be changed.

Enabling or Disabling Video over IP

This feature is useful for masking video. Disabling the video on the Sender unit will mask the video on all connected Receiver units (*multicast mode* only). To mask the video on selected Receiver units, disable the video on the desired Receiver units.

1. Access the Web interface by entering the IP address of the desired Sender or Receiver unit. Refer to [Displaying the IP Address](#) if necessary.
2. Click the **Functions** tab.
3. Check the **Enable Video over IP** box to enable video. Uncheck this box to disable video.

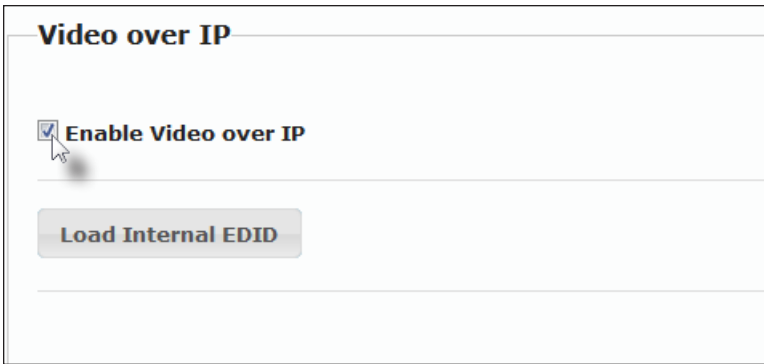

4. Click the **Save** button within the **Video over IP** group.
5. Click the **Reboot** button at the bottom of the page.
6. Repeat steps 1 through 5 for each Sender and/or Receiver unit in the system.

Unicast and Multicast Modes

Configuring Unicast Mode

The term *unicast* is used to describe a configuration where information is sent from one point to another point. It is possible to have multiple Sender and Receiver units connected in a system. However, in unicast mode a Sender unit can communicate with only one Receiver unit at a time. In *unicast* mode, the VGA KVM over IP functions similar to a VGA KVM switcher.



NOTE: The VGA KVM over IP Sender unit and Receiver units shipped from the factory in *unicast mode*.

The illustration, below, shows 3 Sender units (S1, S2, and S3) and 2 Receiver units (R1 and R2) on a network, operating in *unicast* mode. The video channels are notated in blue.

Figure 2.1 - Unicast mode: A Sender unit can communicate with only one Receiver unit at a time.

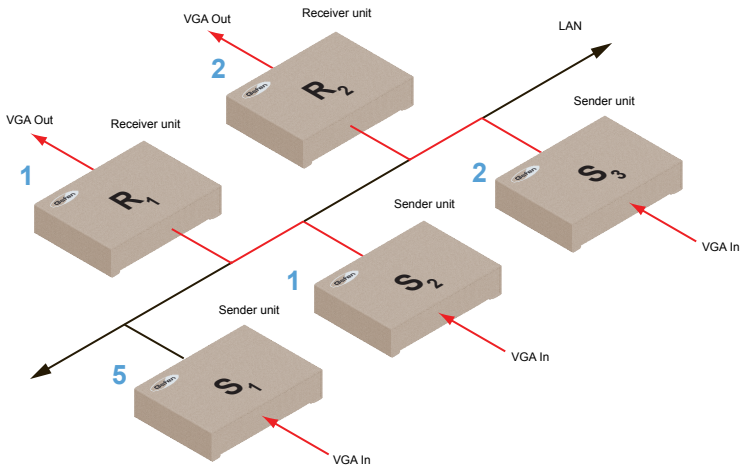

1. Access the Web interface for each Sender and Receiver unit that will be using *unicast mode*. In this example, we will start with Receiver unit R1.
2. Click the **Network** tab.



TIP: In *unicast mode*, the VGA KVM over IP behaves as a VGA KVM Switcher.

- Click the **Unicast** button under the **Network Mode** group. When selected, the **Unicast** button will be highlighted in blue.



- Click the **Save** button in the lower-right corner of the **Network Mode** group.
- The following message will be displayed, at the top of the page, indicating that the casting mode has been applied to the Sender or Receiver unit.

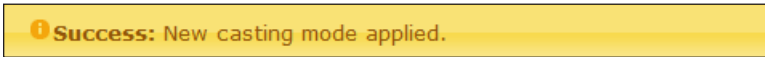

- Click the **Reboot** button near the bottom portion of the page to apply the changes.

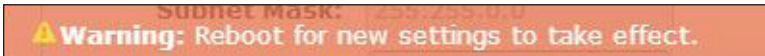

- Repeat steps 1 - 6 in order to configure the Sender unit to *unicast* mode.

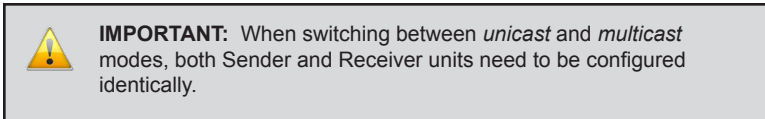

Switching between Sender units in Unicast mode

When multiple Sender and Receiver unit are used in unicast mode, the VGA KVM over IP behaves as a switcher. In *unicast* mode, a Sender unit can communicate with only one Receiver unit at a time.

In the example below, we will switch Receiver unit R1 to receive the VGA source on Sender unit S1.

Figure 2.2 - Unicast mode: Receiver unit R1 is connected to Sender unit S2.

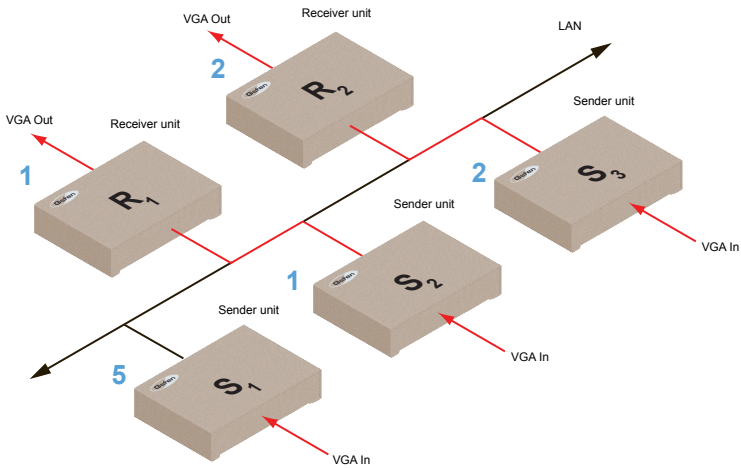

1. Access the Web interface for Receiver unit R1.
2. Click the **Network** tab and change the video channel. Refer to [Setting the Video Channel](#) if necessary.
3. Click the **Save** button.
4. The following message will be displayed, at the top of the page, indicating that the casting mode has been applied to the Sender or Receiver unit.

Success: New casting mode applied.

5. Receiver unit R1 is now receiving the VGA source on Sender unit S1, as shown on the next page.

Figure 2.3 - Unicast mode: Receiver unit R1 is now connected to Sender unit S1.

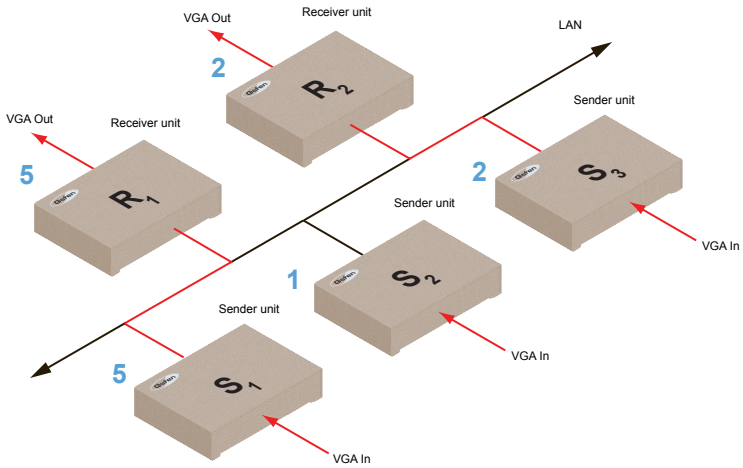

Note that each of the Sender units in Figure 2.3 is assigned a unique channel number. However, if we were to change the video channel on Sender unit S1 to channel 1, this would have violated the *unicast* mode rule: A Sender unit can communicate with only one Receiver unit at a time.

Figure 2.4 - Unicast mode violation: Two Sender units (S1 and S2) using the same video channel.

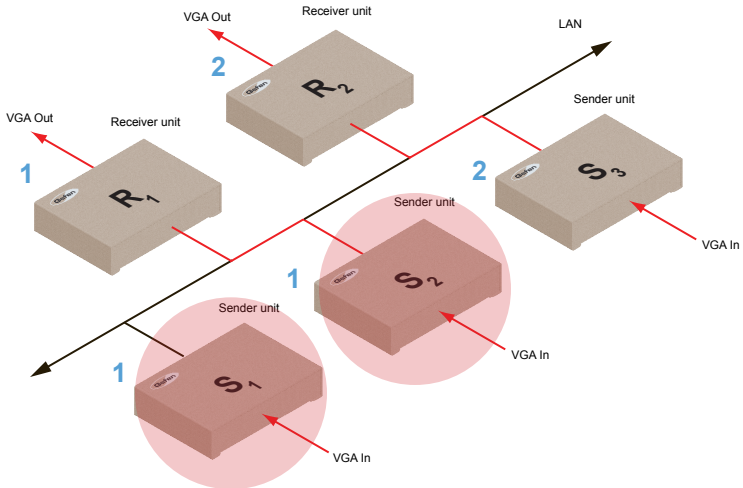

In order to solve the problem, in Figure 2.4, we would need to make sure that each of the Sender units is set to a unique channel number.

When using unicast mode, each of the Sender units must be assigned a unique channel and should never be changed. Use the Receiver unit to switch (channels) between Sender units.

The VGA KVM over IP can be used with up to 256 Sender units to provide switching capability between each Receiver unit. Up to 256 Receiver units are supported. Each Receiver unit can be set to receive video data from any one of 256 Sender units.



NOTE: In unicast mode, if an additional Sender unit is introduced into a system with the same channel as another Sender unit, then the Receiver unit will continue to receive A/V data from the Sender unit which was connected first.

Configuring Multicast Mode

The term multicast is used to describe a configuration where information is sent from one or more points to a set of other points. For example, a single Sender unit can transmit data to multiple Receiver units. In addition, if multiple Sender units are used, each Sender unit can transmit data to any Receiver that is not already receiving data from another Sender unit. In *multicast* mode, the VGA KVM over IP functions similar to a VGA KVM matrix.

The illustration, below, shows 3 Sender units (S1, S2, and S3) and 2 Receiver units (R1 and R2) on a network, operating in *multicast* mode. The video channels are shown in blue.

Figure 2.5 - Multicast mode: A Sender unit can communicate with multiple Receiver units.

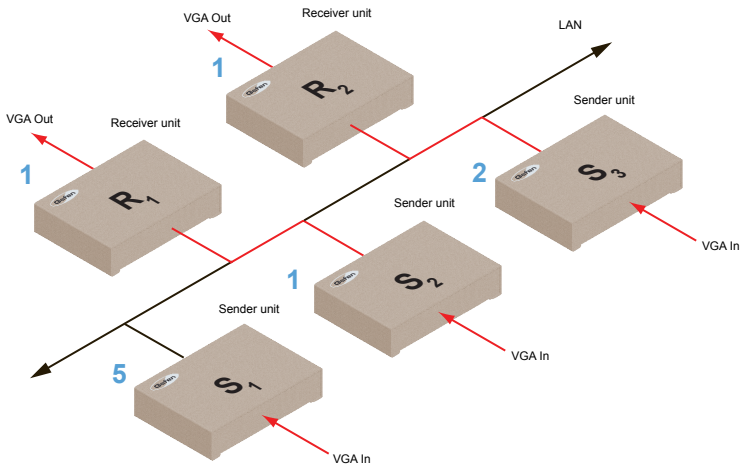

1. Access the Web interface for each Sender and Receiver unit that will be using *multicast mode*. In this example, we will start with Receiver S2.
2. Click the **Network** tab.



TIP: In *multicast mode*, the VGA KVM over IP behaves as a VGA KVM Matrix.

3. Click the **Multicast** button under the **Network Mode** group. When selected, the **Multicast** button will be highlighted in blue.



4. Click the **Save** button in the lower-right corner of the **Network Mode** group.

The following message will be displayed, at the top of the page, indicating that the casting mode has been applied to the Sender or Receiver unit.

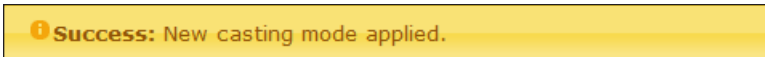

If a display is connected to the Receiver unit, then the message "Starting USB" will be displayed. For more information on using USB under multicast mode, refer to [USB under Multicast Mode](#).

5. Click the **Reboot** button near the bottom portion of the page to apply the changes.

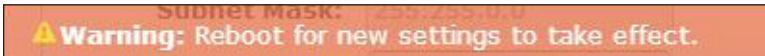

6. Repeat the steps above in order to configure the Sender unit to *multicast* mode.

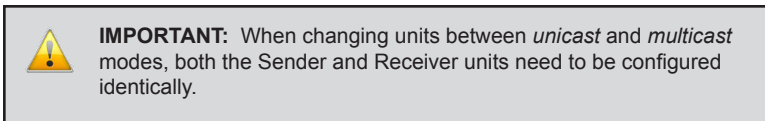

Using RS-232

The *VGA KVM over IP* supports RS-232 pass-through, allowing the control of remote RS-232 devices. The Sender and Receiver unit which are being used to pass-through the RS-232 data must be set to the same baud rate as the RS-232 host and client.

In the example below, the Gefen 4x1 VGA Switcher w/ Audio Decoding (Gefen part no. GTV-AUDDEC-N) has been connected to Receiver unit A. This is the RS-232 client. We want to control this product from Sender unit S3, using a laptop PC (RS-232 host). The channel numbers are listed in blue.

Figure 2.6 - Basic RS-232 connection

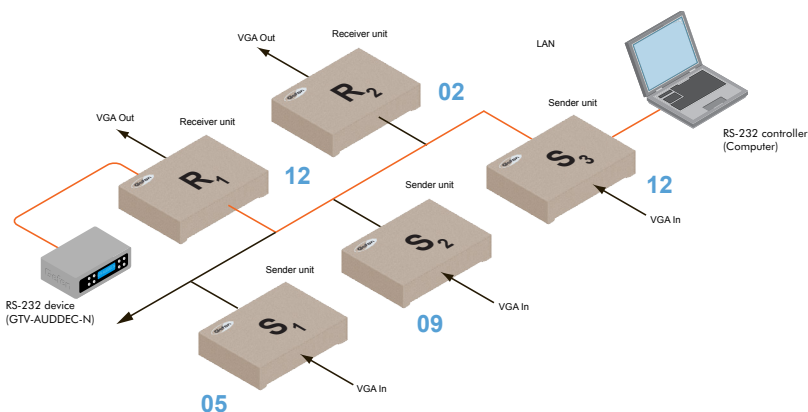

As shown in the User Manual for the Gefen 4x1 VGA Switcher w/ Audio Decoding, the following settings are used:

Table 2.1 - RS-232 settings for the Gefen 4x1 VGA Switcher w/ Audio Decoding

Description	Setting
Baud rate	19200
Data bits	8
Parity	None
Stop bits	1
Hardware flow control	None

Confirm that the same RS-232 settings are assigned to both the Sender and Receiver units. Access the Web interface on both the Sender unit and Receiver unit to set the proper RS-232 settings.

In the example, on the following page, we will begin by setting up Sender unit S3.

1. Access the Web interface for the Sender unit.
2. Click the **Functions** tab.
3. Locate the **Serial over IP** group and change the RS-232 settings to match the settings of the RS-232 device that is being used. In this case, we need to use the settings from Table 2.1

Enable Serial over IP

Baudrate Setting for Type 2:

Baudrate: 19200

Data bits: 8

Parity: None

Stop bits: 1

4. Make sure that the **Enable Serial over IP** box is checked.



NOTE: If **Enable Serial over IP** is not checked, then RS-232 pass-through will be disabled.

5. Click the **Save** button in the lower-right corner of the **Serial over IP** group.
6. The following message will be displayed, at the top of the page, indicating that the new Serial over IP options have been applied.

Success: New Serial over IP options applied.

7. Click the **Reboot** button near the bottom portion of the page to apply the changes.

If the unit is not rebooted within a certain period of time, the “Reboot for new settings to take effect” will be displayed at the top of the page.

8. Repeat steps 1 through 6 for the Receiver unit.

RS-232 under Unicast Mode

In *unicast mode*, a Sender unit will be able to communicate with only one Receiver unit at a time.

Figure 2.7 - In unicast mode, the host can talk to only one RS-232 device at a time.

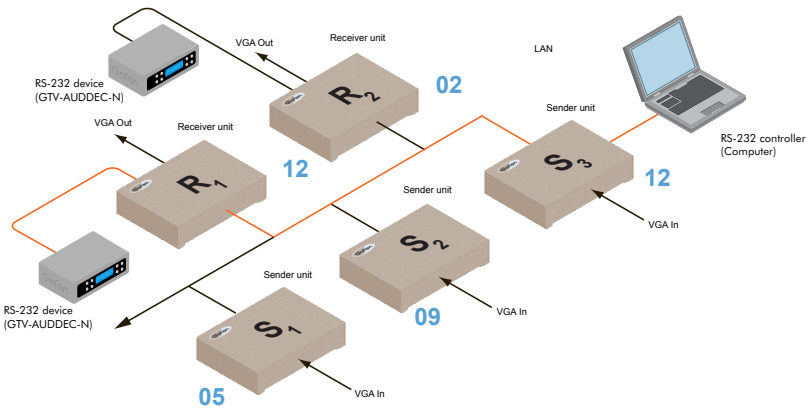

RS-232 under Multicast Mode

In *multicast mode*, a Sender unit can communicate with multiple Receiver units simultaneously.

Figure 2.8 - In multicast mode, the host can talk to multiple RS-232 devices.

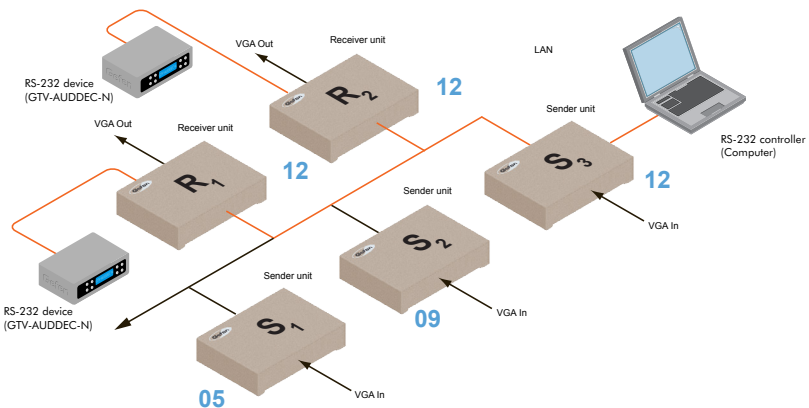

USB Control

USB under Unicast Mode

When connecting USB devices to the VGA KVM over IP, the functionality is similar to that of video and RS-232.



NOTE: By default, the VGA KVM over IP Sender and Receiver units are shipped in *unicast mode*.

As an example, we will start with our original diagram and connect a computer to Sender unit S2 and a keyboard and mouse device to Receiver unit R2. This will allow us to control the computer from the Receiver unit.

Figure 2.9 - Using USB devices under unicast mode.

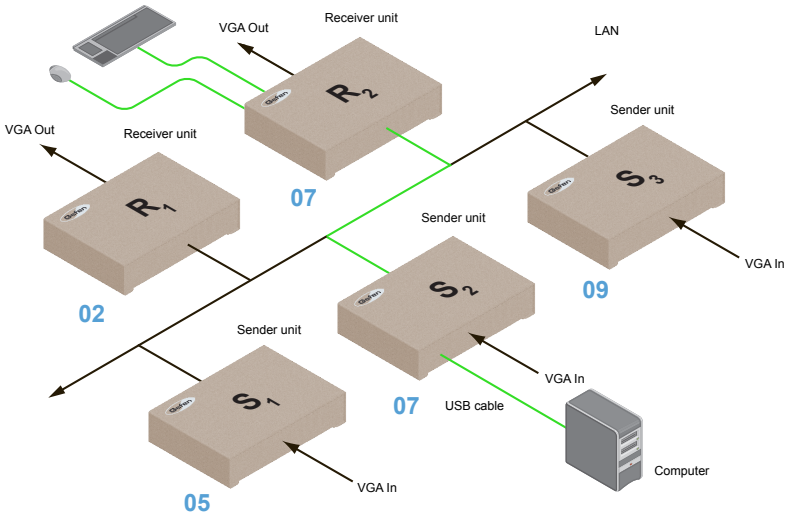

1. Make sure the desired Sender and Receiver units are set to *unicast mode*. Refer to [Configuring Unicast Mode](#) if necessary.
2. Access the Web interface for the Sender unit.
3. Click the **Functions** tab.

4. Locate the **USB over IP** group and make sure the **Enable USB over IP** box is checked. This is the default setting.

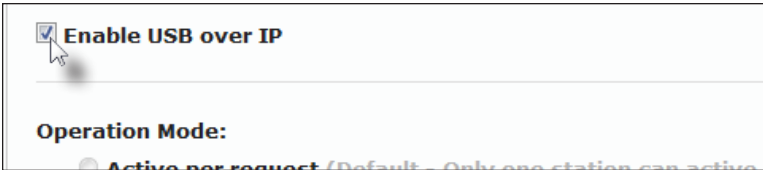

5. In *unicast* mode, the **Operation Mode** is automatically set to **Active on link** and cannot be changed.

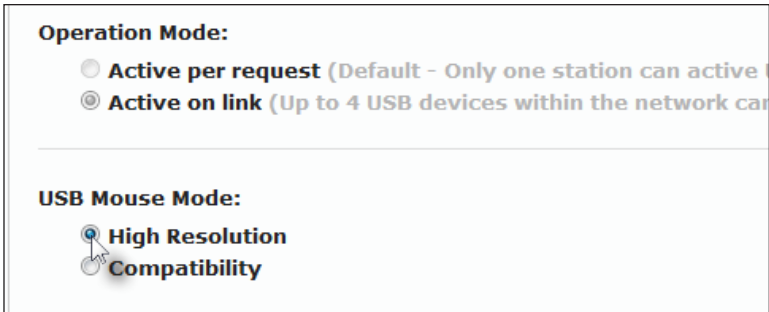

6. Make sure that the **USB Mouse Mode** is set to **High Resolution**. This is the default setting. Use **Compatibility** mode only if using additional KVM switchers or other devices within the system that cause the mouse to behave erratically.
7. Click the **Save** button within the **USB over IP** group.
8. Click the **Reboot** button at the bottom of the page.
9. Connect the USB host (e.g. computer) to the **USB** port on the Sender unit.
10. Connect a USB device (keyboard and/or mouse) to a USB port on the Receiver unit. Up to 4 USB devices can be connected per network in *unicast* mode.
11. The keyboard and mouse (or other USB device) can now be used from the Receiver unit.



IMPORTANT: When enabling or disabling USB over IP, the **Save** and **Reboot** buttons must be clicked to apply changes.

USB under Multicast Mode

When connecting USB devices to the VGA KVM over IP, the functionality is similar to that of video and RS-232. There are two USB modes available in multicast mode: *Active per request* mode and *Active on link* mode.

For an example, we'll begin with the last diagram and connect another keyboard and mouse device to Receiver R1. This will allow us to control the computer from two separate locations.

Figure 2.9 - Using USB devices under multicast mode.

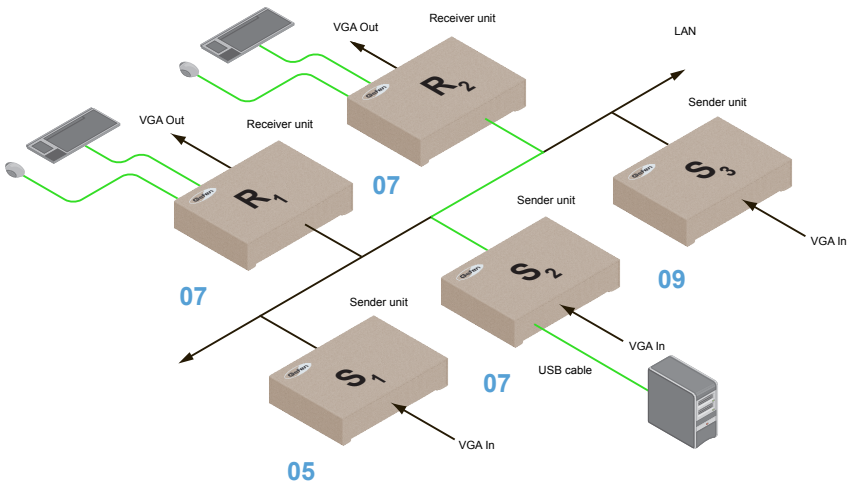

1. Make sure the desired Sender and Receiver units are set to *multicast* mode. Refer to [Configuring Multicast Mode](#) if necessary.
2. Access the Web interface for the Sender unit.
3. Click the **Functions** tab.
4. Locate the **USB over IP** group and make sure the **Enable USB over IP** box is checked. This is the default setting.

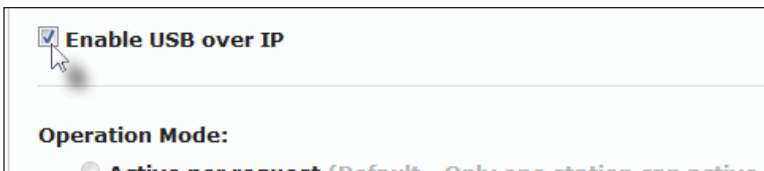

In *multicast* mode, the **Operation Mode** for both Sender and Receiver units are automatically set to **Active per request** mode.

Operation Mode:

- Active per request** (Default - Only one station can active)
- Active on link** (Up to 4 USB devices within the network can)

USB Mouse Mode:

- High Resolution**
- Compatibility**

Under *Active per request* mode, multiple USB devices may be present on one or more Receiver units. However, only one Receiver unit can have USB control at a time.

By default, the first Receiver unit connected to the system will have USB control. In the example, below, Receiver unit R2 currently has control (we arbitrarily connected Receiver unit R2 before Receiver unit R1).

Figure 2.10 - Receiver unit R2 currently has USB control.

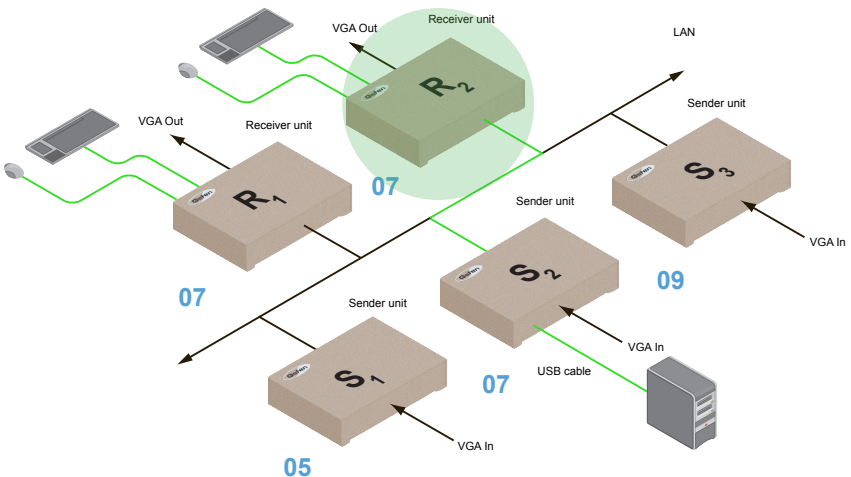

Now, let's look at an example of switching USB control between two Receiver units. Using the diagram, above, we want Receiver unit R1 to have USB control. To assign USB control to another Receiver unit, follow the steps on the next page.

Assigning USB control under Active per request mode

1. Press and hold the **Switch** button on the desired Receiver unit, for at least two seconds. In this example, we will depress the **Switch** button on Receiver unit R1.
2. The message “Starting USB” will appear on the connected display.

Figure 2.11 - Receiver unit R1 has USB control.

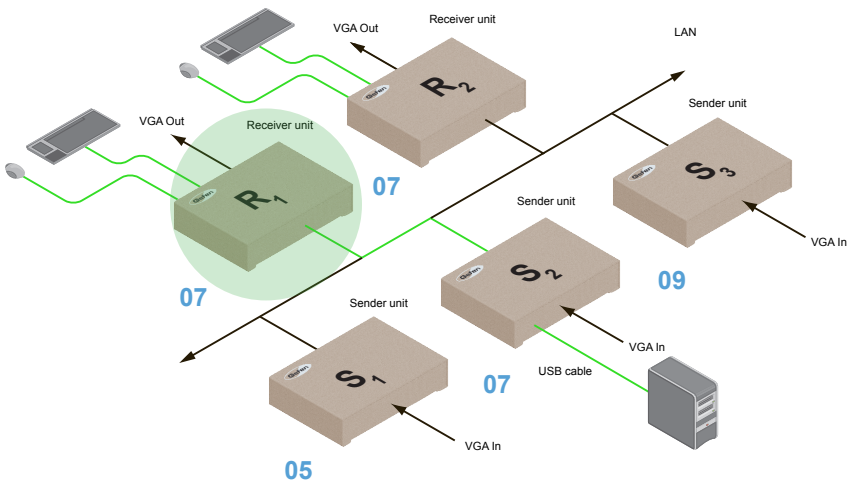

3. In order to assign USB control to a different Receiver unit, repeat steps 1 - 2



IMPORTANT: If switching between *Active per request* mode and *Active on link* mode, the **Save** and **Reboot** buttons must be clicked to apply changes.

Active on link mode

Under *Active on link* mode, a maximum of four USB devices can be used within a system. In the diagram, on the previous page, the system is already using the maximum number of USB devices (2 USB devices per Receiver). If we had two more Receiver units (making a total of four Receiver units), we could have connected a single USB device to each Receiver unit. To switch to *Active on link* mode, follow the instruction below.

1. Access the Web interface for the Sender unit.
2. Click the **Functions** tab.
3. Locate the **USB over IP** group and make sure the **Enable USB over IP** box is checked. This is the default setting.

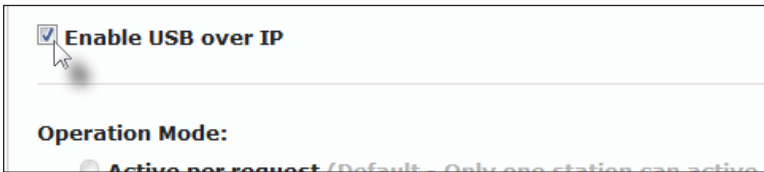

4. Click the **Active on link** radio button within the **USB over IP** group.

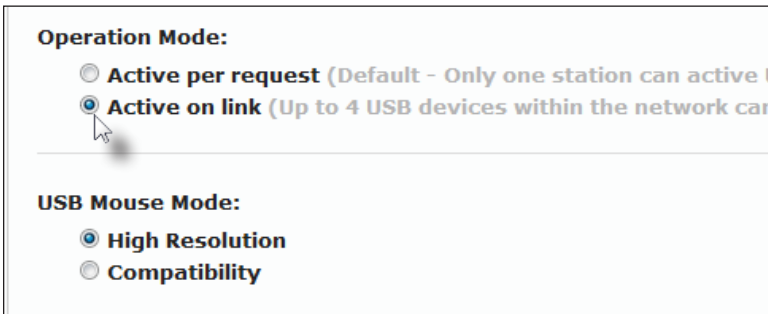

5. Click the **Save** button within the **USB over IP** group.
6. The following message will be displayed, at the top of the page, indicating that the new Serial over IP options have been applied.

Success: New USB options applied.

7. Click the **Reboot** button at the bottom of the page.
8. Repeat steps 2 - 6 for the Receiver unit.

EDID Management

The VGA KVM over IP features EDID Management. Before the source can send video (and/or audio) data, the source device (connected to each Sender unit) reads the EDID (Extended Display Identification Data) from the displays which are connected to each Receiver unit. The EDID contains information about what type of audio/video data can be sent by each source.

By default, the (downstream) EDID from the display, connected to the Receiver unit, is used. However, under certain circumstances, it may be desirable to use the internal EDID which is stored in the Sender unit.

Using the Internal VGA EDID

1. Access the Web interface for the Sender unit.
2. Click the **Functions** tab.
3. Click the **Load Internal EDID** button.



4. After a few moments, the following message will appear at the top of the page, indicating that the new Serial over IP options have been applied.

Success: New video mode applied.

Clicking the **Save** or **Reboot** button is not required for the changes to take effect.

Using the Downstream EDID

By default, the (downstream) EDID from the display, connected to the Receiver unit, is used. If the internal EDID is being used (see [Using the Internal VGA EDID](#)), then use the following procedure to revert to the downstream EDID.

1. Access the Web interface for the Receiver unit.
2. Click the **Functions** tab.
3. Make sure that the **Copy EDID of Connected Display** box is checked. This is the default setting. Click this box if it is not checked then click the **Save** button.



NOTE: Clicking the **Load Internal EDID** button, under the Sender unit, will override the status of the **Copy EDID of Connected Display** check box.

4. Click the **Save** button within the Video over IP group.
5. The following message will be displayed, at the top of the page, indicating that the new Serial over IP options have been applied.

Success: New video mode applied.

6. Click the **Reboot** button at the bottom of the page.
7. The Sender unit will now use the EDID of the downstream sink device.

Audio Connections

Audio works in both unicast and multicast modes. The only difference between the two modes is that the **Mic In** jack is automatically disabled, on all Receiver units, in *multicast* mode. To illustrate how audio works with the VGA KVM over IP, we will set up a microphone and some speakers.

1. Our computer has a **Line In** jack, as part of the sound card and we want to be able to access this jack from the Receiver unit. Therefore, connect the microphone to the **Mic In** jack on the Receiver unit.



2. In order to get the audio from the microphone into the computer, connect a 3.5mm-to-3.5mm mini-stereo cable from the **Line Out** jack on the Sender unit to the **Line In** jack on the computer.

 **WARNING: Do not** connect the mini-stereo cable from the **Line Out** jack on the Sender unit to the **Mic In** jack on the computer. Doing so will result in audio “clipping” and may cause damage to the computer’s sound card.

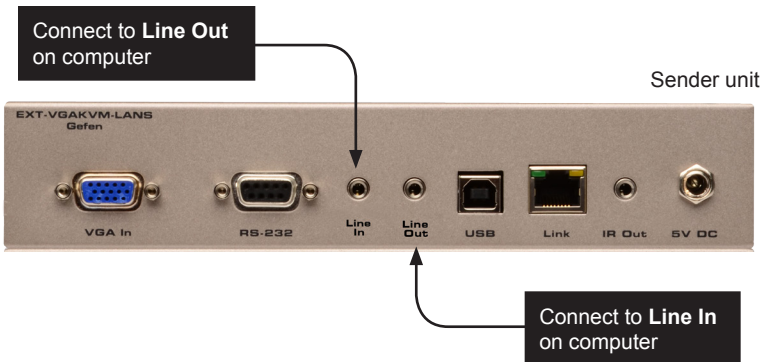

3. Connect another 3.5mm-to-3.5mm mini-stereo cable between the **Line Out** jack on the computer and the **Line In** jack on the Sender unit. Note that any audio device (e.g. MP3 player, etc.) can also be connected to the **Line In** jack on the Sender unit.

- Finally, we'll connect a set of powered computer speakers to the **Line Out** jack on the Receiver unit.

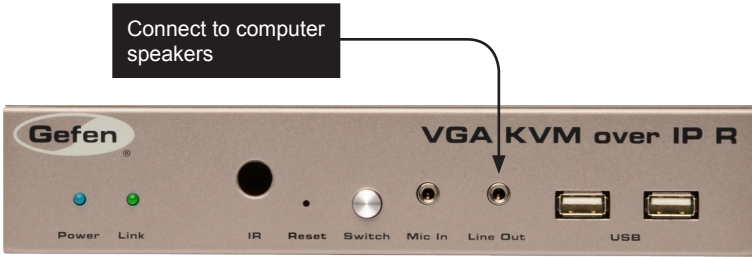

In the diagram below, the mouse and keyboard USB devices have been removed from Sender unit S2 and Receiver unit R2, for purposes of clarity. Arrowheads indicate the audio signal path.

Figure 2.12 - Speaker and microphone connections in unicast mode.

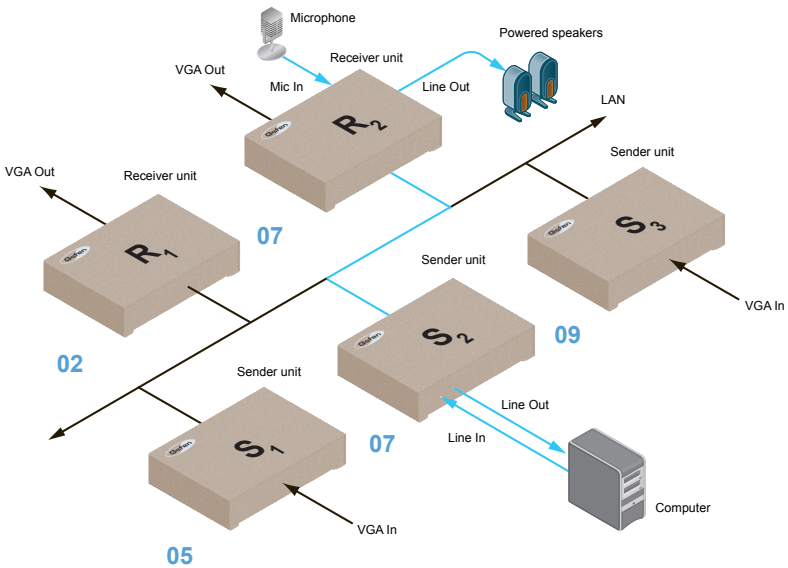
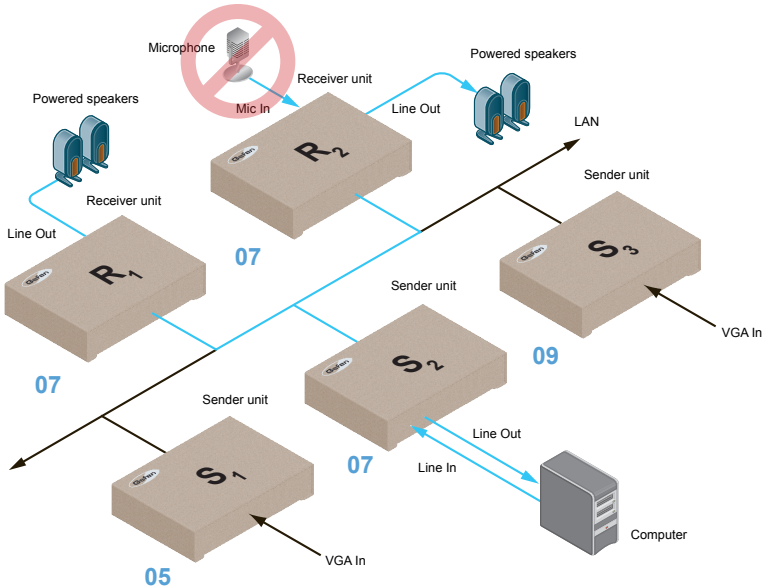

Figure 2.13 - The Mic In jack, on all Receiver units, is automatically disabled in multicast mode.



Using VGA Sources

The VGA KVM over IP will not pass content from HDCP sources such as Blu-ray players and Playstation® console systems.

If a 3.5mm mini-stereo cable is connected to the Line In jack on the Sender unit, then the VGA audio will be disabled on the Receiver unit. The **Line Out** jack, on the Receiver unit, will output audio from the source connected to the **Line In** jack on the Sender unit.

VGA audio cannot be output using the **Line Out** jack on the Receiver unit.

Setting the Video Mode

The *VGA KVM over IP* provides two video modes: Video Mode and Graphic Mode. Consecutively pressing the **Mode** button on the Sender unit will toggle between Video Mode and Graphic Mode.

► Video Mode

If the VGA signal is motion video, then press the **Mode** button on the front panel of the Sender unit until **Video Mode** is displayed. This mode will optimize the frame rate.

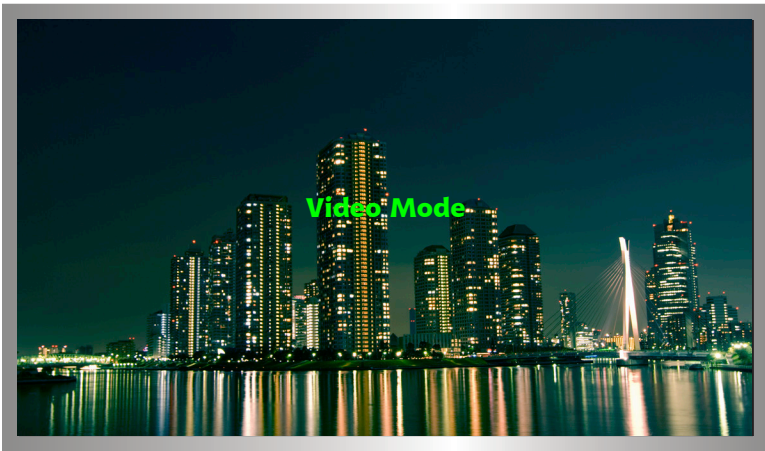

► Graphic Mode

If the VGA signal is a static image, then press the **Mode** button on the front panel of the Sender unit until **Graphic Mode** is displayed.

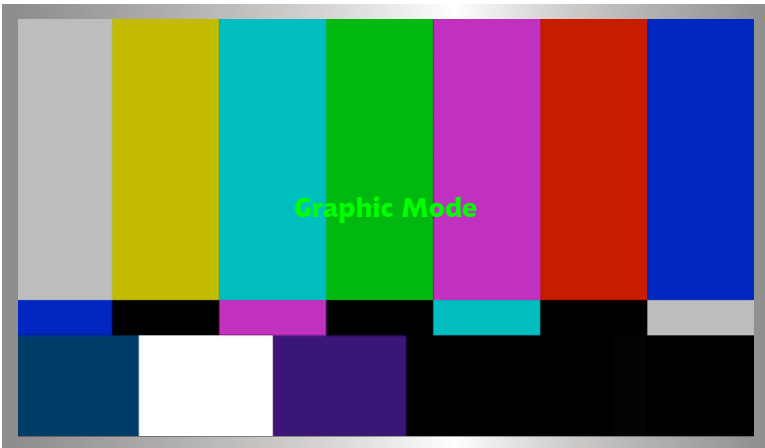

Performing a Factory Reset

To reset a VGA KVM over IP Sender and / or Receiver unit to factory-default settings, follow the instructions below.

Sender Unit



1. Disconnect the power from the Sender unit.
2. Press and hold the **Mode** button.
3. While continuing to press the **Mode** button, reconnect the power.
4. Continue holding the **Mode** button until *both* **Power** and **Link** indicators begin to flash.
5. Use the end of a paper clip or other sharp pointed device to press the **Reset** button.
6. After the **Power** LED indicator stops flashing, the unit will be ready for use.

Receiver Unit



1. Disconnect the power from the Sender unit.
2. Press and hold the **Switch** button.
3. While continuing to press the **Switch** button, reconnect the power.
4. Continue holding the **Switch** button until both **Power** and **Link** indicators begin to flash.
5. Use the end of a paper clip or other sharp pointed device to press the **Reset** button.
6. After the **Power** LED indicator stops flashing, the unit will be ready for use.

VGA | Over KVM IP

03 Appendix

Upgrading the Firmware

The following items are required to upgrade the firmware:

- Gefen VGA KVM over IP
- Computer (Mac or PC)
- Firmware files

1. Download the firmware for the VGA KVM over IP from the Gefen Web site.

To limit the number of channels to 17 or less, please refer to [17 Channels or Less](#) or go to page 47.

2. Extract both firmware files from the .ZIP file. The .ZIP file contains two files:

- ▶ TX_host_kernel_A511_webfwh_v[version]d.bin (Sender unit)
- ▶ RX_client_kernel_A511_webfwc_v[version]d.bin (Receiver unit)

3. Access the Web interface by entering the IP address of the Sender or Receiver unit. The order in which the Sender and Receiver units are upgraded does not matter. Refer to [Displaying the IP Address](#) if necessary.
4. Under the **System** tab, click the **Update Firmware** frame.
5. Click the **Browse...** button and select the firmware for the unit that is being upgraded: If upgrading the Sender unit, select the filename beginning with "TX". If upgrading the Receiver unit, select the filename beginning with "RX".

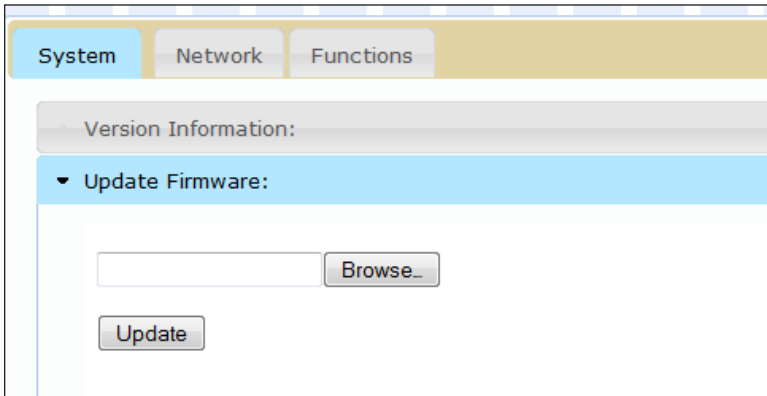

6. Click the **Update** button.
7. After a few moments, the Web interface will indicate that the upgrade process has been started.

▼ Update Firmware:

Firmware Update Progress:

```
firmware file name: TX_host_kernel_A511_webfwh_v1.28d
firmware file size: 4687041 bytes
Decompressing firmware...
Platform matched.
Start programming flash...
programming bootloader...
programming kernel...
```

Please wait... 4 %

- Once the firmware upgrade process has completed, the DVI KVM over IP will reboot.

▼ Update Firmware:

Firmware Update Progress:

```
firmware file name: TX_host_kernel_A511_webfwh_v1.28d
firmware file size: 4687041 bytes
Decompressing firmware...
Platform matched.
Start programming flash...
programming bootloader...
programming kernel...
programming rootfs...
programming rootfs patch...
programming parameters...
Programming completed
```

DONE. Rebooting...

- Repeat the process for each Sender and Receiver unit in the system.

17 Channels or Less

The following items are required to upgrade the firmware to a limited number of channels:

- Gefen VGA KVM over IP
- Computer (Mac or PC)
- Firmware files

1. Download the firmware for th VGA KVM over IP from the Gefen Web site.
2. Extract the firmware files from the .ZIP file. The .ZIP file contains two files:

▶ webfwc_131v-ch00XX

XX denotes the number of maximum channels

3. Access the Web interface by entering the IP address of the Receiver unit. Refer to [Displaying the IP Address](#) if necessary.
4. Under the **System** tab, click the **Update Firmware** frame.
5. Click the **Browse...** button and select the number of channels needed.

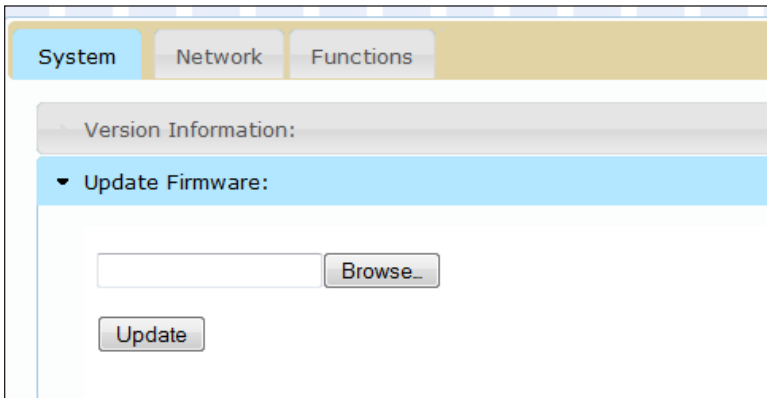

6. Click the **Update** button.
7. After a few moments, the Web interface will indicate that the upgrade process has been started.

▼ Update Firmware:

Firmware Update Progress:

```
firmware file name: TX_host_kernel_A511_webfwh_v1.28d
firmware file size: 4687041 bytes
Decompressing firmware...
Platform matched.
Start programming flash...
programming bootloader...
programming kernel...
```

Please wait... 4 %

8. Once the firmware upgrade process has completed, the VGA KVM over IP will reboot.

▼ Update Firmware:

Firmware Update Progress:

```
firmware file name: TX_host_kernel_A511_webfwh_v1.28d
firmware file size: 4687041 bytes
Decompressing firmware...
Platform matched.
Start programming flash...
programming bootloader...
programming kernel...
programming rootfs...
programming rootfs patch...
programming parameters...
Programming completed
```

DONE. Rebooting...

9. Repeat the process for each Receiver unit in the system.

Developer Notes

The following information is intended for developers that use the VGA KVM over IP product as part of their application.

To change the routing on the Sender and Receiver unit, the following URL needs to be issued:

```
http://IP/cgi-bin/query.cgi?callback=jQuery15101605335909232362_1370475364360&cache=false&nocache=1370480983843&cmd=astparam+s+multicast_ip+225.0.100.inpStr%3Bastparam+s+ch_select+inp%3Bast_send_event+-1+e_reconnect&wrap_type=multi_line
```

where:

ID	Name
IP	Receiver IP
inpStr	3-digit number of the Sender channel
inp	Sender channel

Example:

To change the Receiver at 192.168.2.100 to display Sender channel 2:

```
http://192.168.2.100/cgi-bin/query.cgi?callback=jQuery15101605335909232362_1370475364360&cache=false&nocache=1370480983843&cmd=astparam+s+multicast_ip+225.0.100.002%3Bastparam+s+ch_select+2%3Bast_send_event+-1+e_reconnect&wrap_type=multi_line
```

Network Cable Diagram

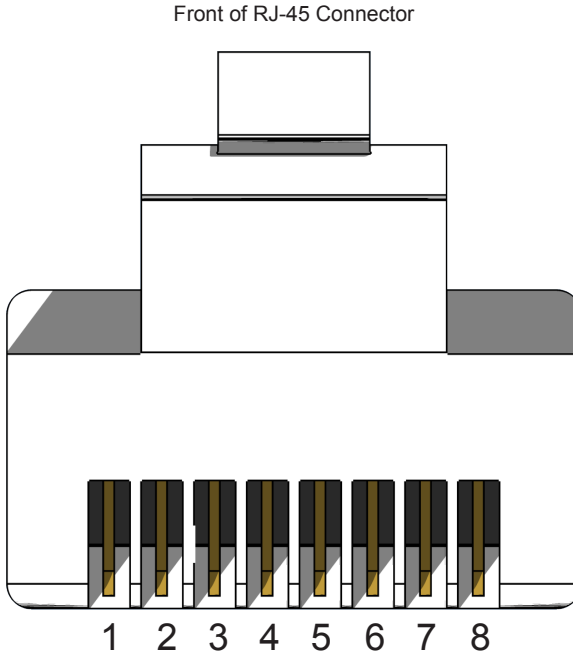

Gefen recommends the TIA/EIA-568-B wiring option. Use the table below when field-terminating cable for use with Gefen products.

Pin	Color	Description
1	Orange / White	TD+ (Transmit Data, positive differential signal)
2	Orange	TD- (Transmit Data, negative differential signal)
3	Green / White	RD+ (Receive Data, positive differential signal)
4	Blue	Unused
5	Blue / White	Unused
6	Green	RD- (Receive Data, negative differential signal)
7	Brown / White	Unused
8	Brown / White	Unused

Shielded (STP) CAT-5 or CAT-6 is recommended. However, unshielded (UTP) CAT-5 or CAT-6 is acceptable. CAT-5, CAT-5e, and CAT-6 cabling comes in stranded and solid core types. Gefen recommends using solid core cabling. CAT-6 cable is also recommended.

It is recommended to use one continuous run from one end to the other. Patch cable is not recommended.

Rack Tray Installation

The following illustrations provide instructions for installing the Sender and/or Receiver unit(s) in the *Gefen 1U Rack Tray* (Gefen part no. EXT-RACK-1U).

Step 1 Turn unit upside down.

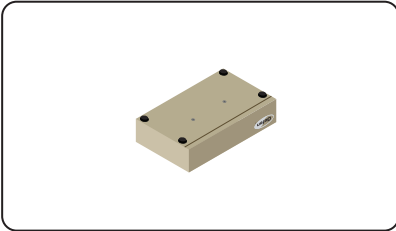

Step 2 Remove rubber feet.

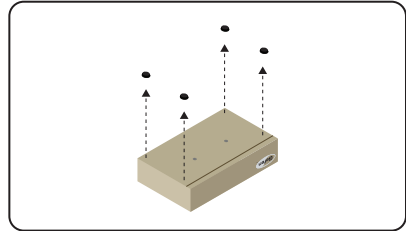

Step 3 Line up holes on unit and rack tray.

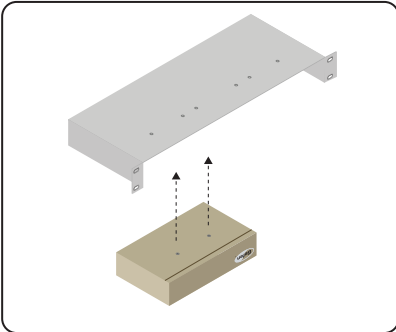

Step 4 Install countersink screws.

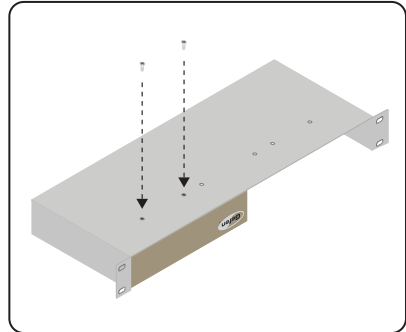

Step 5 Ensure the unit is installed securely.

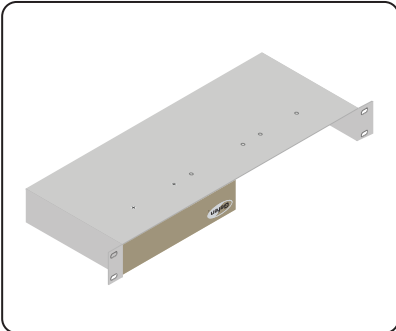

Step 6 Unit has been installed into rack tray.

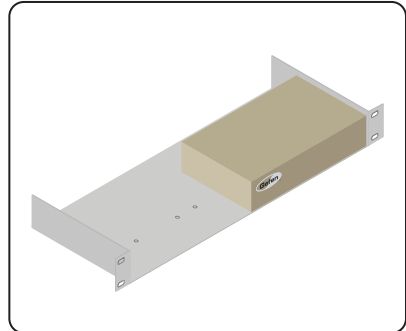

Specifications

Supported Formats

Resolutions (max.)	<ul style="list-style-type: none"> 1920 x 1200 (WUXGA)
--------------------	---

Electrical

Maximum Pixel Clock	<ul style="list-style-type: none"> 350 MHz
Link indicator (Sender / Receiver)	<ul style="list-style-type: none"> 1 x LED, green
Power indicator (Sender / Receiver)	<ul style="list-style-type: none"> 1 x LED, blue

Connectors

Video Input (Sender)	<ul style="list-style-type: none"> 1 x VGA HD-15, female
Video Output (Receiver)	<ul style="list-style-type: none"> 1 x VGA HD-15, female
Audio (Sender)	<ul style="list-style-type: none"> 1 x 3.5mm mini-stereo (Line In) 1 x 3.5mm mini-stereo (Line Out)
Audio (Receiver)	<ul style="list-style-type: none"> 1 x 3.5mm mini-stereo (Line Out) 1 x 3.5mm mini-stereo (Mic In)
USB (Sender)	<ul style="list-style-type: none"> 1 x Type B, female
USB (Receiver)	<ul style="list-style-type: none"> 2 x Type A, female
Ethernet (Sender)	<ul style="list-style-type: none"> 1 x RJ-45
Ethernet (Receiver)	<ul style="list-style-type: none"> 3 x RJ-45, shielded
IR Emitter (Sender)	<ul style="list-style-type: none"> 1 x 3.5mm mini-mono jack
IR Ext. (Receiver)	<ul style="list-style-type: none"> 1 x 3.5mm mini-stereo jack
RS-232 (Sender)	<ul style="list-style-type: none"> 1 x DB-9, female
RS-232 (Receiver)	<ul style="list-style-type: none"> 1 x DB-9, male

Control

Reset button (Sender)	<ul style="list-style-type: none"> 1 x Push button, tact-type
Mode button (Sender)	<ul style="list-style-type: none"> 1 x Push button, tact-type
Switch button (Receiver)	<ul style="list-style-type: none"> 1 x Push button, tact-type

Operational

Power Input (Sender / Receiver)	• 1 x 5V DC, locking
Power Consumption (Sender / Receiver)	• 10W (max.)

Physical

Dimensions (W x H x D) (Sender / Receiver)	• 8.4" x 1.7" x 4.5" (213mm x 43mm x 113mm)
Unit Weight (each unit)	• 2 lbs (0.9 kg)



Stretch it, Switch it, Split it, Control it.
Gefen's got it. ®

20600 Nordhoff St., Chatsworth CA 91311
1-800-545-6900 818-772-9100 fax: 818-772-9120
www.gefen.com support@gefen.com



This product uses UL or CE listed power supplies.