

Blackmagic Pocket Cinema Camera 4K



\$1,295

The Blackmagic Pocket Cinema Camera 4K features a 4/3 size sensor, 13 stops of dynamic range and dual native ISO up to 25,600 for HDR images and incredible low light performance. External controls give quick access to essential functions, while the large 5 inch touchscreen makes it easy to frame shots, focus accurately and change camera settings. Features include built in SD/UHS-II or CFast 2.0 recorders for Blackmagic RAW or ProRes recording as well as a USB-C expansion port for recording externally to disks, plus MFT lens mount, built-in microphones, XLR input, full sized HDMI, 3D LUT support, Bluetooth and more.

Camera Features

Effective Sensor Size

18.96mm x 10mm (Four Thirds)

Lens Mount

Active MFT mount.

Lens Control

Iris, focus and zoom on supported lenses.

Dynamic Range

13 Stops.

Dual Native ISO

400 and 3200

Shooting Resolutions

4096 x 2160 (4K DCI) up to 60 fps
 4096 x 1712 (4K 2.4:1) up to 75 fps
 3840 x 2160 (Ultra HD) up to 60 fps
 2880 x 2160 (2.8K Anamorphic) up to 80 fps
 2688 x 1512 (2.6K 16:9) up to 120 fps
 1920 x 1080 (HD) up to 120 fps

Frame Rates

Maximum sensor frame rate dependent on resolution and codec selected. Project frame rates of 23.98, 24, 25, 29.97, 30, 50, 59.94 and 60 fps supported.

Off-speed frame rates up to 60 fps in 4K DCI, 120 fps in 2.6K 16:9 and HD windowed.

Focus

Auto focus available using compatible lenses.

Iris Control

Iris wheel and touchscreen slider for manual iris adjustment on electronically controllable lenses, iris button for instant auto iris settings on compatible lenses.

Screen Dimensions

5" 1920 x 1080.

Screen Type

LCD capacitive touchscreen.

Metadata Support

Automatically populated lens data from electronic Micro Four Thirds lenses. Automatic recording of camera settings and slate data such as project, scene number, take and special notes.

Controls

Touchscreen menus on 5 inch screen. 1 x Power Switch, 1 x Record Button, 1 x Stills Button, 1 x Scroll Wheel with push integrated into handgrip, 1 x ISO Button, 1 x White Balance, 1 x Shutter Button, 3 x software configurable Fn buttons, 1 x High Frame Rate (HFR) Button, 1 x Zoom Button, 1 x Menu Button, 1 x Play Button, 1 x Focus Button and 1 x IRIS Button.

Connections

Total Video Inputs

None.

Total Video Outputs

1 x HDMI up to 1080p60

Analog Audio Inputs

1 x mini XLR analog switchable between mic with phantom power support and line level (up to +14dBu).
1 x 3.5mm Stereo Input. Can also be used for Timecode input.

Analog Audio Outputs

1 x 3.5mm headphone jack.

Computer Interface

USB Type-C for external drive recording, PTP camera control and software updates.

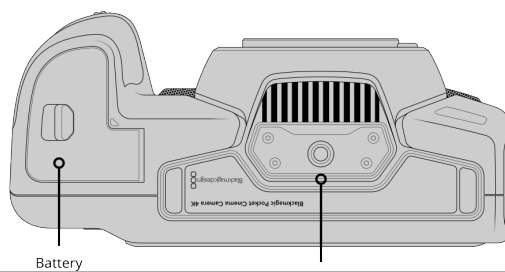
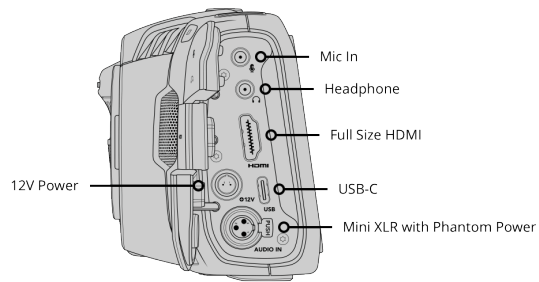
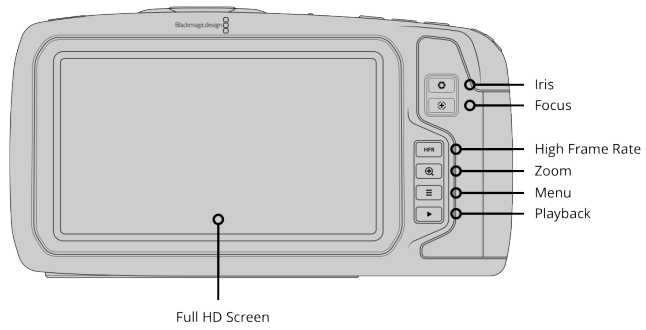
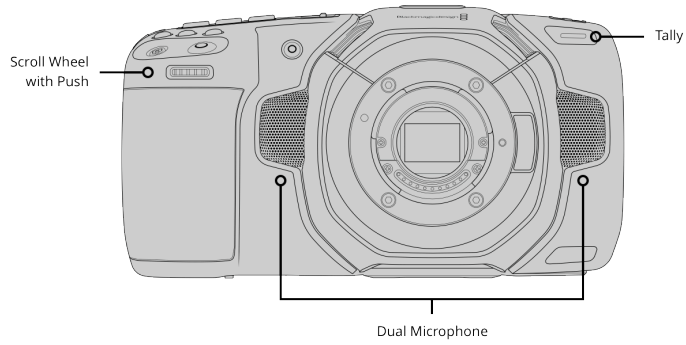
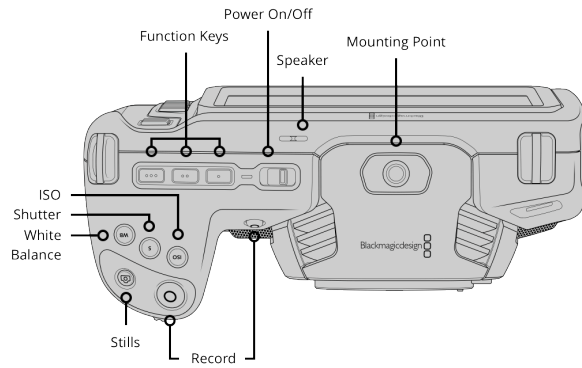

Audio

Microphone

Integrated stereo microphone.

Built in Speaker

1 x mono speaker.

Standards

SD Video Standards

None.

HD Video Standards

1080p23.98, 1080p24, 1080p25,
1080p29.97, 1080p30, 1080p50,
1080p59.94, 1080p60.

Ultra HD Video Standards

2160p23.98, 2160p24, 2160p25,
2160p29.97, 2160p30, 2160p50,
2160p59.94, 2160p60.

4K DCI Standards

4KDCIp23.98, 4KDCIp24, 4KDCIp25,
4KDCIp29.97, 4KDCIp30, 4KDCIp50,
4KDCIp59.94, 4KDCIp60.

Media

Media

1 x CFast card slot, 1 x SD UHS-II card slot, 1 x USB-C 3.1 Gen 1 expansion port for external media for Blackmagic RAW and ProRes Recording. Please refer to either the Manual or the Information Note at www.blackmagicdesign.com/support for compatible media.

Media Format

Can format media to ExFAT (Windows/Mac) or HFS+ (Mac) file systems.

Supported Codecs

Codecs

Blackmagic RAW Constant Bitrate 3:1,
Blackmagic RAW Constant Bitrate 5:1,
Blackmagic RAW Constant Bitrate 8:1,
Blackmagic RAW Constant Bitrate 12:1,
Blackmagic RAW Constant Quality Q0,
Blackmagic RAW Constant Quality Q5,
ProRes 422 HQ QuickTime,
ProRes 422 QuickTime,
ProRes 422 LT QuickTime,
ProRes 422 Proxy QuickTime.

Control

External Control

iPad control, Bluetooth control, USB PTP camera control

Storage Features

Storage Type

1 x CFast 2.0.
1 x SD UHS-II card.
1 x high speed USB-C expansion port for external media.

Storage Rates

Storage rates based on 30 frames per second.

4096 x 2160

Blackmagic RAW 3:1 - 135 MB/s
Blackmagic RAW 5:1 - 81 MB/s
Blackmagic RAW 8:1 - 51 MB/s
Blackmagic RAW 12:1 - 34 MB/s
Blackmagic RAW Q0 - 81 to 203 MB/s
*

Blackmagic RAW Q5 - 21 to 58 MB/s
**

Apple ProRes 422 HQ - 117.88 MB/s
Apple ProRes 422 - 78.63 MB/s
Apple ProRes 422 LT - 54.63 MB/s
Apple ProRes Proxy - 24.25 MB/s

4096 x 1712

Blackmagic RAW 3:1 - 108 MB/s
Blackmagic RAW 5:1 - 65 MB/s
Blackmagic RAW 8:1 - 41 MB/s
Blackmagic RAW 12:1 - 27 MB/s
Blackmagic RAW Q0 - 65 to 161 MB/s
*

Blackmagic RAW Q5 - 17 to 47 MB/s
**

*

Constant Quality setting Q0 storage rates quoted are indicative only, based on a 2:1 - 5:1 compression range.

**

Constant Quality setting Q5 storage rates quoted are indicative only, based on a 7:1 - 20:1 compression range.

Actual storage rates are entirely dependent on image subject matter.

3840 x 2160

Blackmagic RAW 3:1 - 127 MB/s
Blackmagic RAW 5:1 - 76 MB/s
Blackmagic RAW 8:1 - 48 MB/s
Blackmagic RAW 12:1 - 32 MB/s
Blackmagic RAW Q0 - 76 to 190 MB/s
*

Blackmagic RAW Q5 - 19 to 55 MB/s
**

Apple ProRes 422 HQ - 110 MB/s
Apple ProRes 422 - 73.6 MB/s
Apple ProRes 422 LT - 51 MB/s
Apple ProRes Proxy - 22.4 MB/s

2880 x 2160

Blackmagic RAW 3:1 - 96 MB/s
Blackmagic RAW 5:1 - 58 MB/s
Blackmagic RAW 8:1 - 36 MB/s
Blackmagic RAW 12:1 - 24 MB/s
Blackmagic RAW Q0 - 58 to 143 MB/s
*

Blackmagic RAW Q5 - 15 to 41 MB/s
**

2688 x 1512

Blackmagic RAW 3:1 - 63 MB/s
Blackmagic RAW 5:1 - 38 MB/s
Blackmagic RAW 8:1 - 24 MB/s
Blackmagic RAW 12:1 - 16 MB/s
Blackmagic RAW Q0 - 38 to 94 MB/s
*

Blackmagic RAW Q5 - 10 to 27 MB/s
**

1920 x 1080

Blackmagic RAW 3:1 - 33 MB/s
Blackmagic RAW 5:1 - 20 MB/s
Blackmagic RAW 8:1 - 13 MB/s
Blackmagic RAW 12:1 - 8 MB/s
Blackmagic RAW Q0 - 20 to 49 MB/s *
Blackmagic RAW Q5 - 5 to 14 MB/s **

Apple ProRes 422 HQ - 27.5 MB/s
Apple ProRes 422 - 18.4 MB/s
Apple ProRes 422 LT - 12.75 MB/s
Apple ProRes Proxy - 5.6 MB/s

Recording Formats

Blackmagic RAW 3:1, 5:1, 8:1, 12:1, Q0 and Q5 at 4096 x 2160, 4096 x 1712, 3840 x 2160, 2880 x 2160, 2688 x 1512 and 1920 x 1080 with film, extended video or video dynamic range. ProRes at 4096 x 2160, 3840 x 2160 and 1920 x 1080 with film, extended video or video dynamic range or custom 3D LUT.

Software

Software Included

Pocket Cinema Camera 4K
Operating System.
DaVinci Resolve Studio on SD Card.
Blackmagic Camera Setup.

Operating Systems



Mac 10.14 Mojave,
Mac 10.15 Catalina or later.



Windows 10.

Power Requirements

Power Supply

1 x External 12V power supply.

Battery Type

Canon LP-E6.

Power

12V-20V

External Power Input

1 x 2-pin locking connector.

Battery Life

Approximately 60 minutes
(recording at 24 fps without any
external USB-C device connected)

Accessories

Optional Accessories

Blackmagic Pocket Camera Battery Grip.

Physical Specifications



Environmental Specifications

Operating Temperature

0° to 40°C (32° to 104°F)

Storage Temperature

-20° to 45°C (-4° to 113°F)

Relative Humidity

0% to 90% non-condensing

What's Included

Blackmagic Pocket Cinema Camera 4K
Lens turret dust cap
30W power supply with locking connector and international adapters
LP-E6 battery
SD card with software and manual
Welcome card
DaVinci Resolve Studio with activation key

Warranty

Product Warranty

12 Month Limited Manufacturer's Warranty.

All items on this website are copyright Blackmagic Design Pty. Ltd. 2019, all rights reserved.
All trademarks are property of their respective owners. MSRP includes duties, but excludes sales tax and shipping costs.
This website uses remarketing services to advertise on third party websites to previous visitors to our site.
You can opt out at any time by changing cookie settings. [Privacy Policy](#)

Blackmagic Design Authorized Reseller