



CI820 PRODUCT SPECIFICATIONS

NOMINAL IMPEDANCE	16Ω
SENSITIVITY dB @ 2.83V/1M	86 dB
FREQUENCY RESPONSE	55 Hz - 22 kHz
RECOMMENDED POWER	10 - 80 Watts
TAP SELECTOR	Six-Position Rotary Switch or Transformer Bypass Position
TWEETER	1" (25.4 mm) Silk Dome
MIDRANGE	N/A
WOOFER	8.0" (203.2 mm) Polypropylene w/ Butyl Rubber Surround
ENCLOSURE MATERIAL	Drawn Steel Backcan w/ ABS Baffle
ENCLOSURE TYPE	Ported
INPUTS	Ceramic Terminal Connector
GRILLE	Painted Steel
COLOR OPTIONS	Black or White
DIMENSIONS	11.75" (298.5 mm) Diameter x 8.0" (203.2 mm) Depth
CUTOUT DIMENSIONS	10.5" (266.7 mm) Diameter
MOUNTING DEPTH	8.34" (211.8 mm)
WEIGHT	9 lbs
SHIPPING WEIGHT	10 lbs
INCLUDED ACCESSORIES	Tile Bridge, UL-Listed Flex Conduit Clamp, Paint Shield
OPTIONAL ACCESSORIES	Pre-Construction Bracket (AC-CI20-PCB), Tile Bridge (AC-CI20-TB)
REGULATORY - UL	UL1480 & 2043 Approved
REGULATORY - CE	Approved
RoHS	Approved

Description:

The CI620 is a 8" coaxial in-ceiling speaker in a steel backcan with a tuned front port.

Mounting hardware is included as well as a SpeedWing™ constant-tension fixed-wing mounting system. The CI820 also features a six-position tap switch enables 25-, 70.7- and 100-volt applications with a transformer bypass position into 16Ω.

Features:

- One 8 inch polypropylene woofer with butyl rubber surround
- One 1 inch silk dome tweeter
- Limited Lifetime Warranty
- Auto-Reset Overload Protection
- Absolute Phase Crossover Network
- Painted White Steel Grille
- Included Accessories: color-coded tile bridge, conduit clamp, paint shield
- Optional Accessories: pre-construction bracket (AC-CI20-PCB), tile bridge (AC-CI20-TB)
- UL 1480 & 2043 Approved

Applications:

Engineered for home theater or distributed audio applications where high-efficiency, added bass response and rapid installation are critical.

Transformer Taps:

70.7 V	OUTPUT	100 V	OUTPUT	25 V	OUTPUT
64 W	107.0 dB	64 W	107.0 dB	8 W	98.0 dB
32 W	104.0 dB	32 W	104.0 dB	4 W	95.0 dB
16 W	101.0 dB	16 W	101.0 dB	2 W	92.0 dB
8 W	98.0 dB	8 W	98.0 dB	1 W	89.0 dB
4 W	95.0 dB				

Warranty Information:

The CI820 comes with a limited lifetime warranty. Products not sold through an authorized dealer/distributor will not be supported by the factory warranty. Warranties are non-transferable.

Phase Technology:

8005 W 110th St
Suite 208
Overland Park, KS 66102
Phone: 913.663.5600
Toll Free: 855.663.5600
Fax: 913.663.3200
www.phasetech.com

Mechanical Drawings

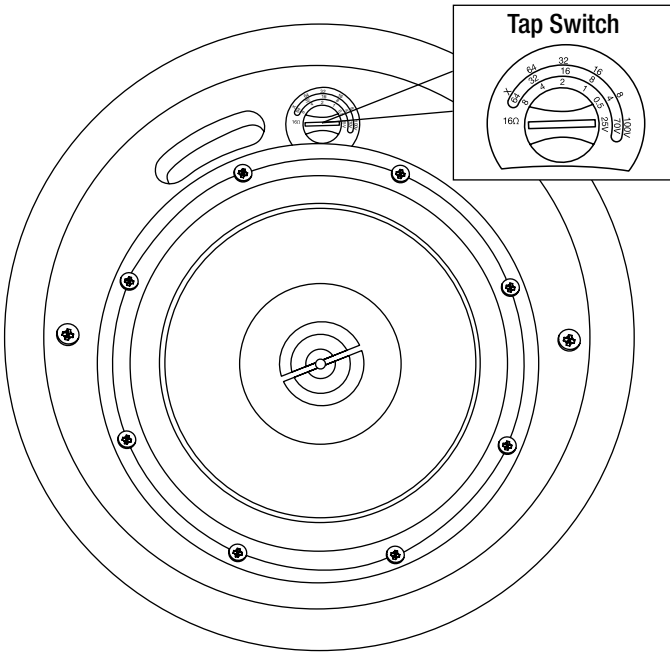
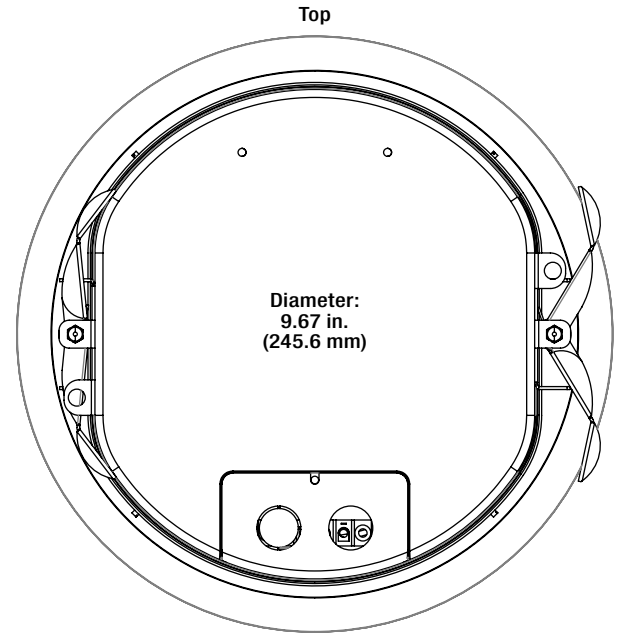
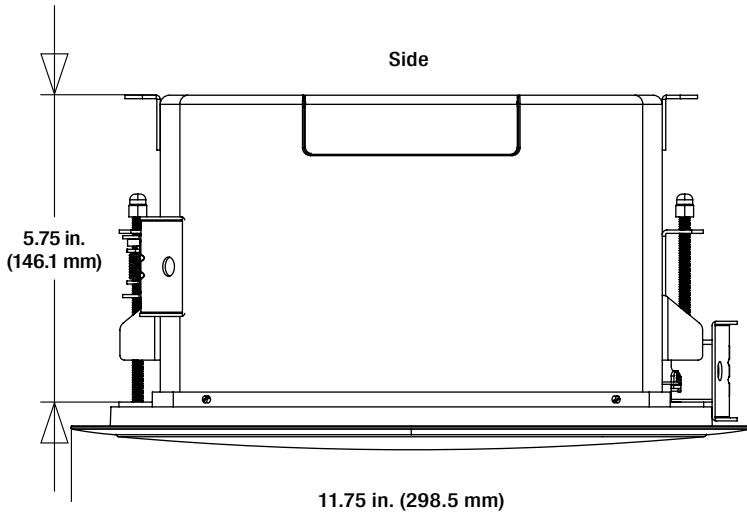

Included Accessories
Paint Mask

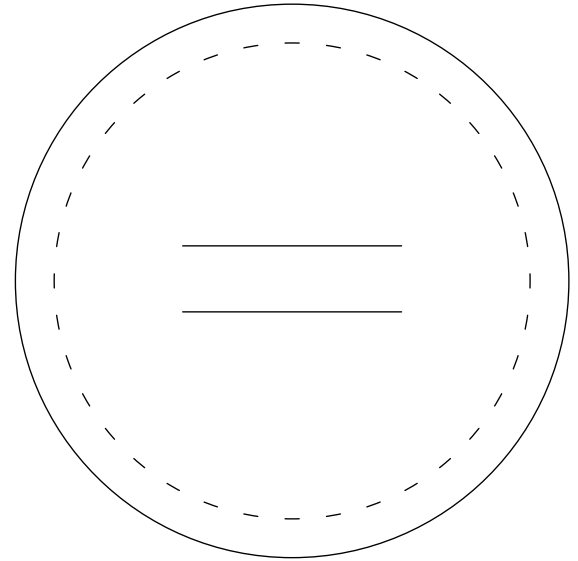

Optional Accessories

Pre-Construction Bracket (AC-CI20-PCB)

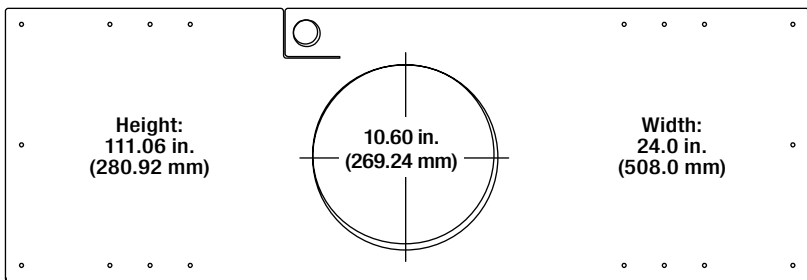

Tile Bridge (AC-CI20-TB)

