

datavideo



4K PTZ Camera
PTC-280

www.datavideo.com

4K PTZ Camera

Brand New 4K PTZ Camera Lineup

Live productions depend on high performance cameras and camera controllers.

Datavideo is introducing the 4K50/60p PTZ camera PTC-280, professional PTZ cameras help you capture your event. PTC-280 can be easily controlled via traditional RS-422 serial port, or IP remote control via DVIP (Datavideo proprietary protocol) or Sony VISCA over IP. This brand new 4K camera series supports dual streaming output for A/V market application, you can easily stream to Facebook (RTMPS), YouTube and dvCloud.





PTC-280



- 2160p50/59.94/60 PTZ camera
- 1/2.5" CMOS
- Excellent low light performance (0.5 Lux @ F1.8, AGC ON)
- 12x Optical Zoom, 16x Digital Zoom
- 4K Video inputs: HDMI 2.0, 3G-SDI, IP (H.264 & H.265)
- 2160p and 1080p (3G-SDI) Simultaneous video output
- RS-422 Serial Control
- DVIP (Datavideo Proprietary Protocol) Control
- Supports Sony VISCA via browser and VISCA over IP Protocol
- External audio input: 3.5mm audio in
- Friendly web UI via browser & app (iOS and Android)
- Dual streaming: 2160p and 720p simultaneously

PTC-280/ PTC-280W





0 1

IRID

RS-422

MIC IN/
LINE IN

3G-SDI

4K HDMI

F/W
UPGRADE
ONLY

DC 12V

DVIP

datavideo **PTC-280** 4K PTZ CAMERA

Various Control Options

Control real-time pan, tilt, and zoom camera movements with Datavideo PTZ View Assist APP, RMC-300A and RMC-180. With configurable preset positions supported.



PTZ View Assist



RMC-180



RMC-300A

Multiple Network Protocol with Dual Stream function

Support RTSP and RTMPS protocols, easy to stream directly to two different CDN platforms and Datavideo dvCloud as well.



Multiple simultaneous video outputs

Supports simultaneous HDMI 2.0 and IP output up to 2160p 50/60 and also 3G-SDI output up to 1080p60/50.



Broadcast quality 4K HDMI / 3G-SDI PTZ camera

Resolution is up to 2160p 50/60. 12x optical zoom for PTC-280 which giving you a perfect video.



Low Noise in low light CMOS effectively ensures high SNR of video quality.

Advanced 2D/3D noise reduction technology is also used to further reduce the noise while ensuring image sharpness.



Supports H.264/H.265 video compression

Support compression of resolution up to 3840x2160 with frame up to 59.94, 60fps and the second channel 1280x720p with 30fps compression. AAC, MP3 and PCM audio compression also supported.



Tally Light

Green and red lights tally to show the preview and program status for broadcast applications.



RS-422, DVIP and Ethernet Camera Control

RS-422 and ethernet to use DVIP or VISCA over IP commands to integrate with larger control systems.



White balance

Focus

IRIS

Monitoring



PTZ View Assist

Control up to four cameras with your Wireless Touch Screen



The camera control app is tailored for the Datavideo PTZ camera series. It can monitor the live streaming video from PTC-140 and PTC-280. The app can control up to 4 cameras simultaneously via DVIP, you can intuitively set up and recall the presets, and adjust white balance, focus, and IRIS. The app can decode the live streaming via RTSP (SRT and NDI steaming coming soon), easily monitor the live streaming video and set up the parameters promptly in one application. Datavideo provides iOS and Android versions, you can download on Google Play and App Store for free!



Mobile phone version available soon



Camera Control

Camera

Protocol

Position



Camera control via web UI APP control

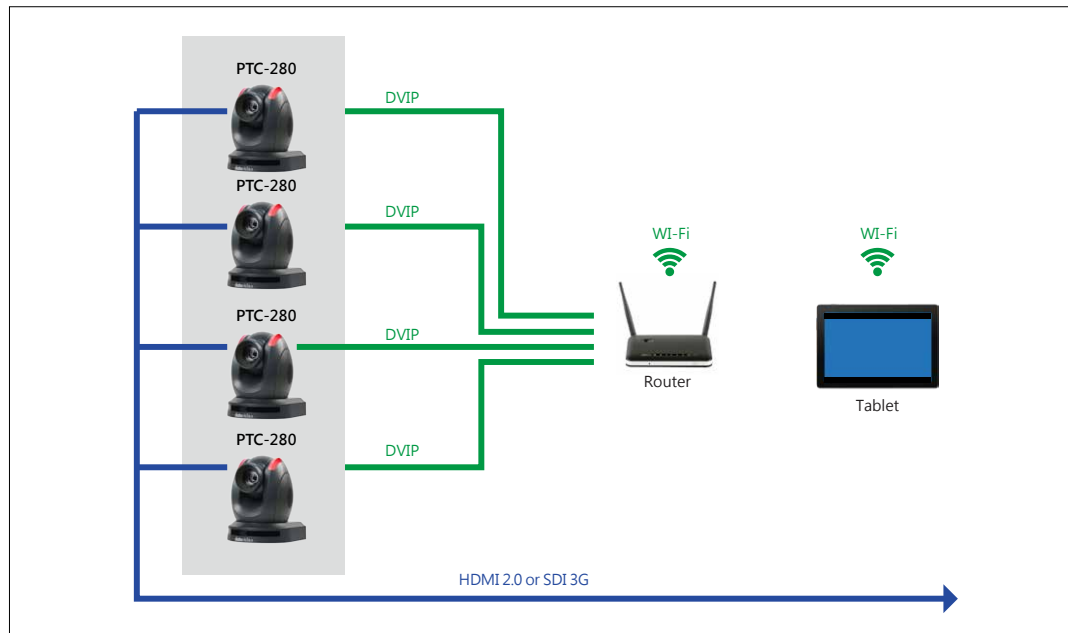

The camera control app is able to control datavideo PTZ cameras. Once you install the app on the tablet, easy to control the cameras in the same network!

Camera control via RS-422 up to 4 cameras

By using RMC-180 PTZ Camera Control Unit, you can simply RS-422 to control up to 4 PTZ cameras. With its ergonomic joystick and tactile button layout, the RMC-180 makes it easy to set up and control for any live video production.

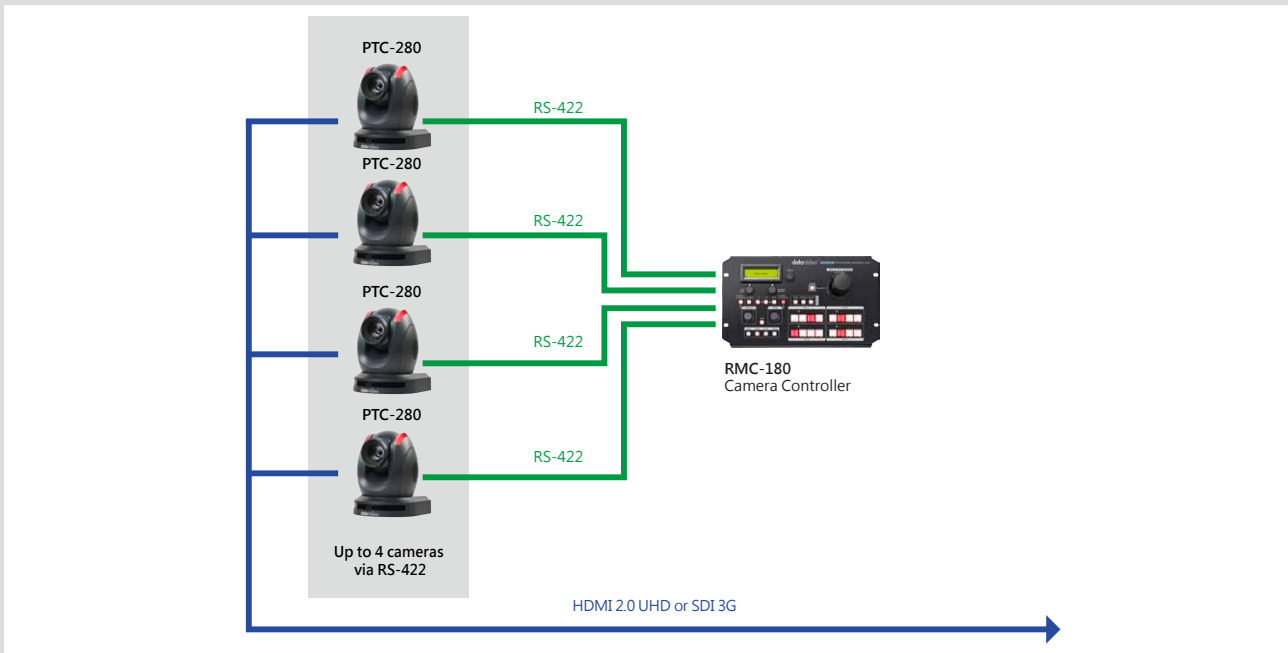

Camera control via RS-422 up to 8 cameras

By using RMC-300A Universal Remote Control Panel, you can simply RS-422 to control up to 8 PTZ cameras. With its combination of interface on 5" panel and hardware buttons, RMC-300A enable users to manage heavy EFP workflow without haste.

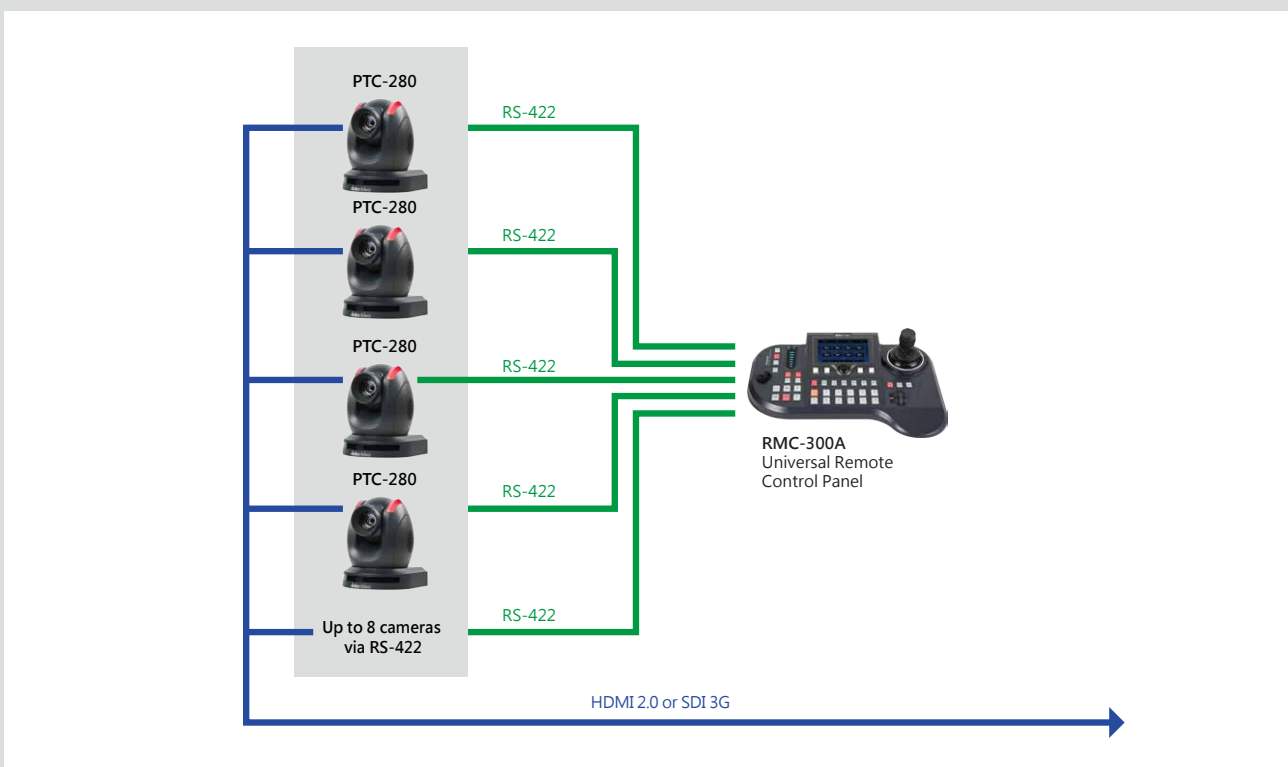

Camera control via DVIP or VISCA over IP up to 24 cameras

By using RMC-300A Universal Remote Control Panel with DVIP control protocol, you can simply RS-422 and DVIP to control up to 24 PTZ cameras. With its combination of interface on 5" panel and hardware buttons, RMC-300A enable users to manage heavy EFP workflow without haste.

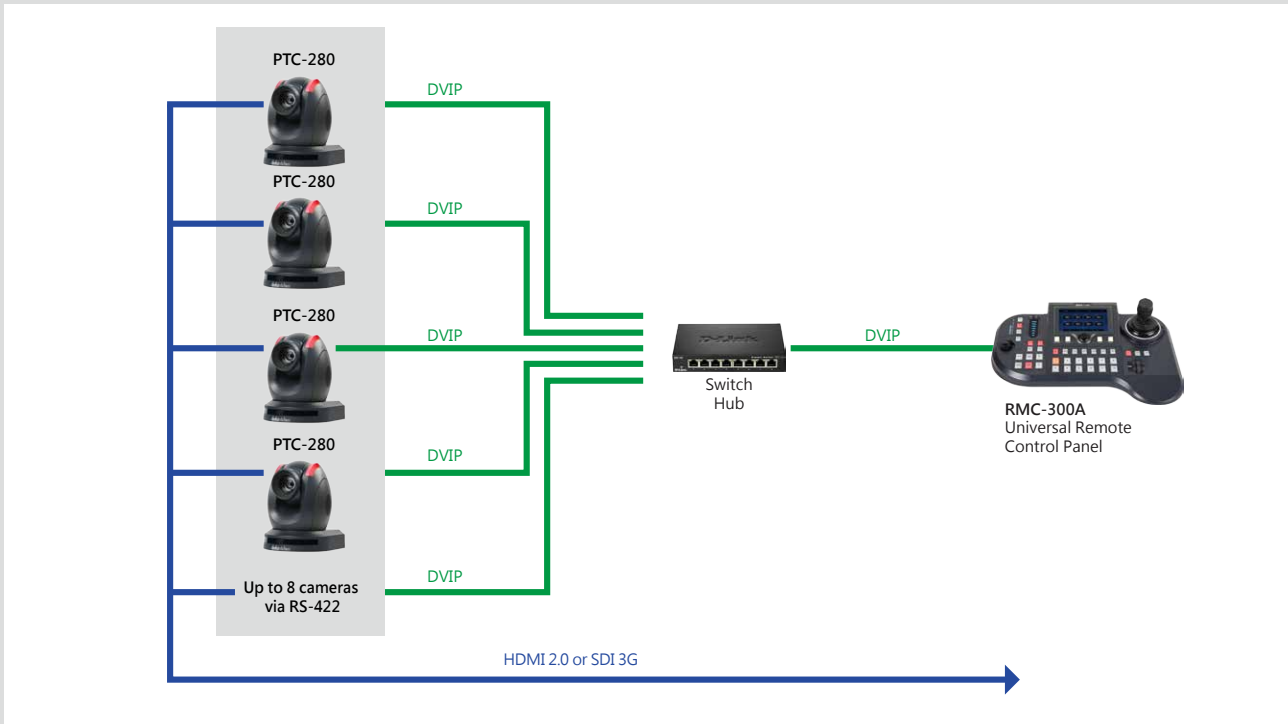

Chromakey

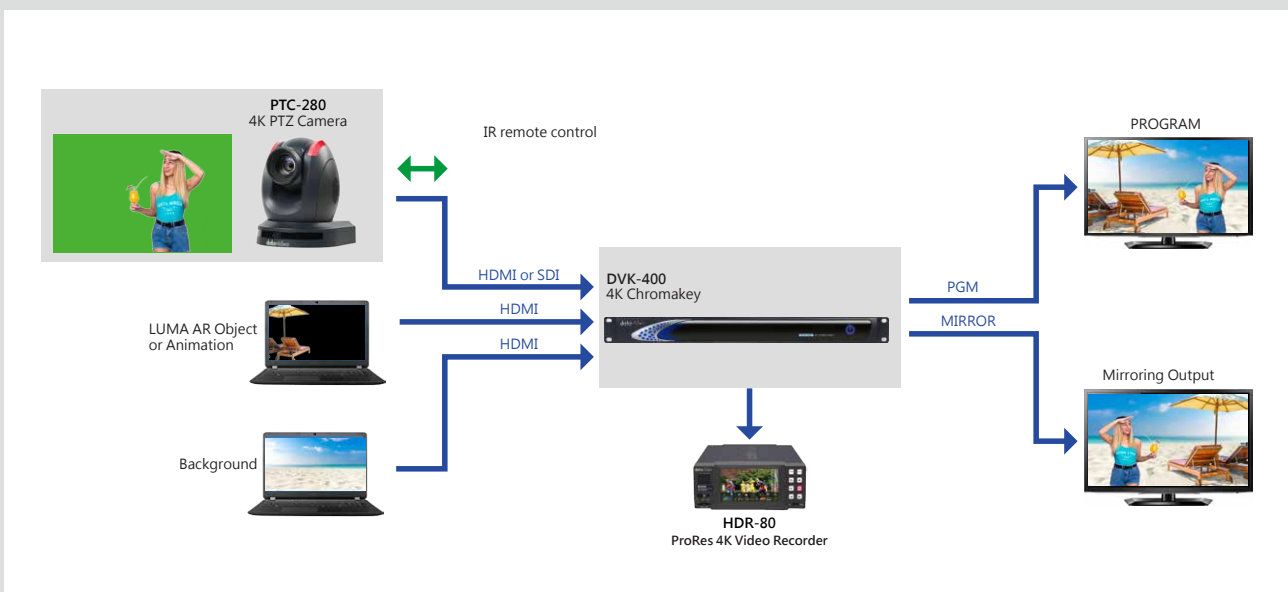

KMU-200

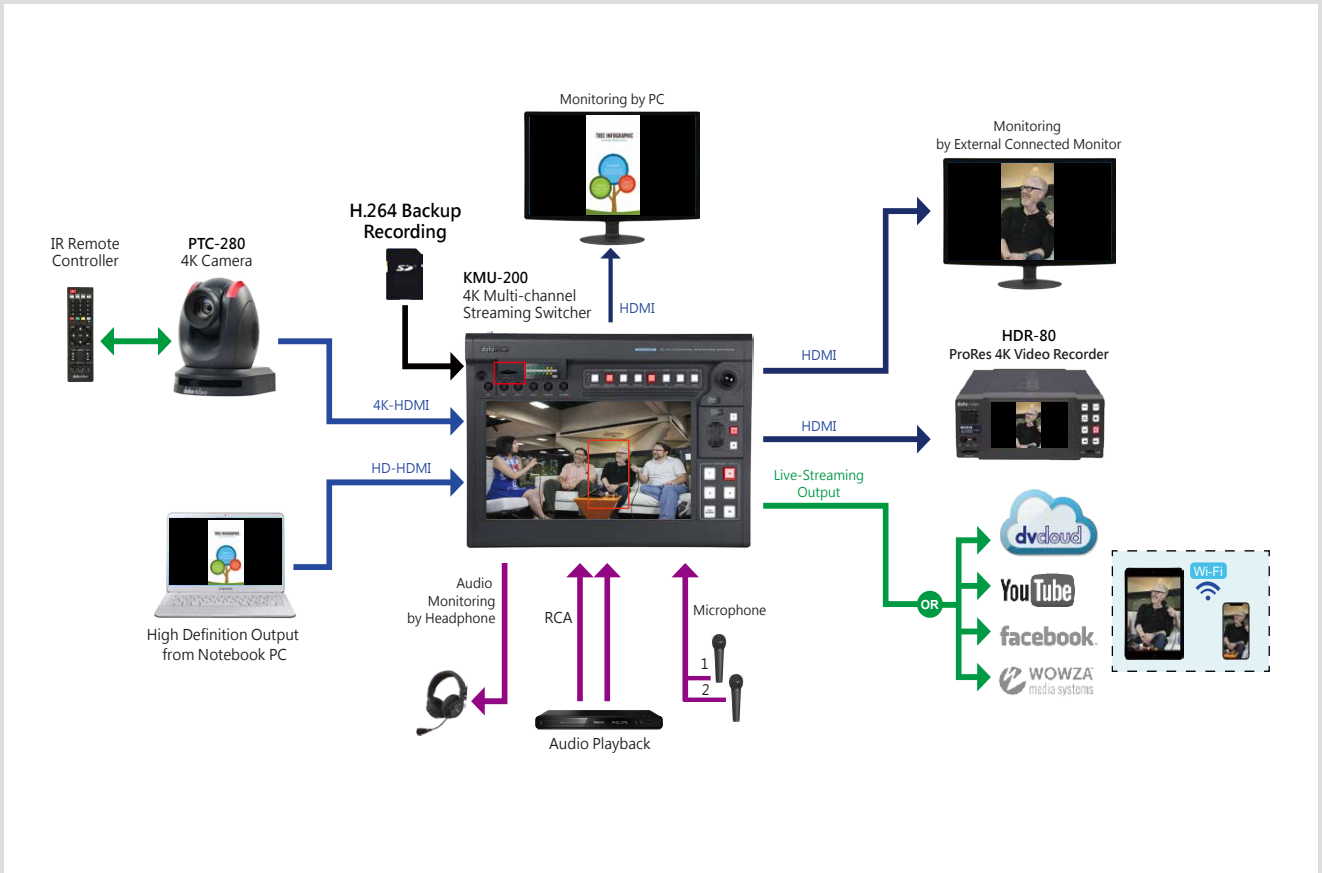

Related Products

Switcher Series



KMU-200
4K Multi-Channel Streaming Switcher

KMU-200 is an all-in-one solution for producing full HD virtual multi-camera video using a single 4K camera. By uses a large touch screen for operation , pinching and swiping, and control up to 4 cutouts of a 4K image and as if the footages comes from 4 different cameras.

Intro.



Video



Chremakeyer



DVK-400
4K Chromakey

DVK-400 is a professional broadcast grade live chromakey processor that works with resolutions up to 2160p60. This real-time chromakey processor provides 4:4:4 10-bit internal processing for the best results.

Intro.



Video



Camera Controller



RMC-300A
Universal Remote Control Panel

RMC-300A is a multi-functional Multi-camera Controller. It is able to control up to 12 PTZ and block cameras by Ethernet or up to 8 cameras by serial port RS-422 transmission.



RMC-180
PTZ Camera Controller

RMC-180 is a PTZ camera control unit, and it simple multi-camera control at your fingertips. With its ergonomic joystick and tactile button layout, the RMC-180 makes it easy to set up and control up to four Datavideo PTZ cameras.

Intro.



4K Recorder



HDR-80
ProRes 4K Dual Disk Recorder

HDR-80 is able to record video in resolutions up to 2160p60 using the available SDI and HDMI interfaces. With multiple HDMI and SDI inputs you can also record up to four 1080p sources at the same time, using the HDR-80 as an ISO recorder.

Intro.



Optional accessories



VP-929
HDMI 4K Repeater

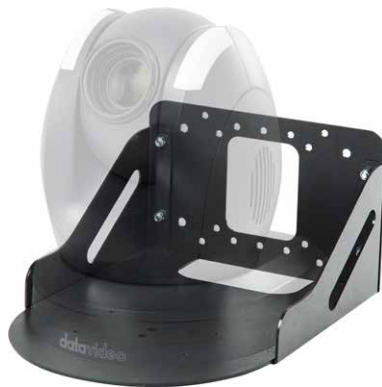

WM-1
Wall Mount



WM-1W
Wall Mount (White)

The WM-1 can be positioned upside-down or rightside-up to suit various applications. The three-piece design is sturdy, and easy to install onto any wall.

What's in the box accessories



IR remote control



Ceiling mount bracket



DC 12V Adaptor

Dimension

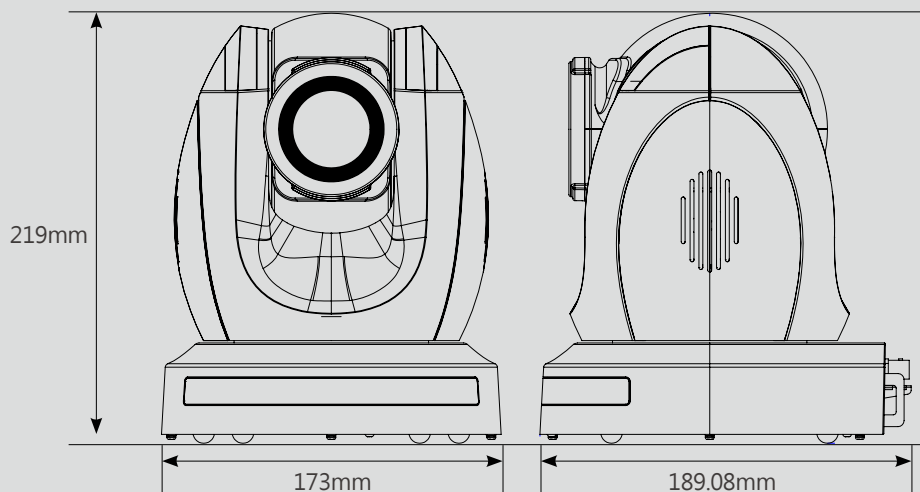

Model Name	PTC-280
Video format	2160p60/59.94/50/30/29.97/25 1080p60/59.94/50/30/29.97/25 1080i60/59.94/50 720p60/59.94/50 (2160p60/59.94/50 YUV 4:2:0 only)
Image Sensor	1/2.5" CMOS
Effective Pixels (approx.)	8.51Mega Pixels
S/N Ratio	≥55dB
Min. Illumination	0.5 Lux @ (F1.8, AGC ON)
Electronic Shutter	1/30s ~ 1/10000s
Zoom Ratio	12x Optical Zoom, 16x Digital Zoom
Gamma Control	Off / Normal
Iris Control	Auto / Manual
Digital Noise Reductions	2D/3D
HDR	TBC
On-Screen Display (OSD)	English/Simplified Chinese/Traditional Chinese
White Balance	Auto, Indoor, Outdoor, OnePush, Manual, VAR
AGC / Gain Control	Yes
Mirror / Flip Image	Yes
Focus Mode	Auto/Manual
Panning / Tilting Range	Pan: 300° , Tilt: +130° to -15°
Panning / Tilting Speed	Pan: 0.876°/s~43°/s Tilt: 0.693°/s ~21.32°/s
Preset	255
Focal Length	12x, f = 6.7mm ~125mm, F1.58 ~ F3.95
Field of View (Horizontal, Wide)	71°
Image Compensation	Back light compensation
Video Output	HDMI 2.0 x1 3G-SDI x1 10/100/1000M RJ45 x1
Audio Input	3.5 mm x1
Tally LED	Yes
Lens Filter	N/A
Control Protocol	Pelco-D, Pelco-P, VISCA, VISCA over IP DHCP, RTSP, RTMP (IP Cam), RTMPS, DVIP
Remote Control Interface and Transmit Distance	IR , Web UI , RS-422 , DVIP
Video Compression Format	H.264/H.265/MJPEG
Audio Compression Format	AAC
Audio Bitrate	96Kbps, 128Kbps, 256Kbps
HD IP Interface	----
Streaming Protocols	TCP/IP, HTTP, RTSP, RTMP(S), ONVIF, DHCP, Multicast
First Stream Supported Resolution	3840x2160 , 1920x1080 , 1280x720 , 1024x576 960x540 , 640x480 , 640x360
Second Stream Supported Resolution	1280x720 , 1024x576 , 720x576 (50Hz) , 720x480 (60Hz) 720x408 , 640x360 , 480x270 , 320x240
Video Bitrate	32Kbps ~ 50Mbps (Single Stream)
Video Bitrate Mode	VBR, CBR
Encoding Frame rate	50Hz: 1-50fps 60Hz: 1-60fps
POE	N/A
F/W Update	Via Web UI or USB 2.0
IR Control	Yes
Camera Control Unit	RMC-180, RMC-300A, RMC-300C
Tripod Mount	1/4-20 UNC
Optional Accessories	WM-1/ WM-10/ WM-11
Color	Dark Blue/White
Dimension (LxWxH)	173 (W) x 219 (H) x 189.08 (D)
Weight	2.8 kg
Operating Temp. Range	0~40 °C
Power	DC 12V



@DatavideoUSA @DatavideoAsia
@DatavideoEMEA @DatavideoIndia2016
@DatavideoTaiwan @Datavideojapan



@Datavideo
@Datavideo_EMEA
@Datavideo_Taiwan



@DatavideoUSA
@DVTWDVCN



@DatavideoUSA
@DatavideoEurope

Disclaimers of Product and Services

This brochure is intended as a guide only. We reserve the right to change specifications and availability without prior notice. While we strive for complete accuracy, be aware that it may contain errors and omissions. Prior to purchase, please check with your local Datavideo office or authorised distributor.

Ver.20210302