



hear
TECHNOLOGIES®

The personal monitor system artists and studios choose for its simplicity and high-quality sound. Whether or not you've ever used a personal monitor mixer, the simple layout of this powerful system makes getting the right mix a quick and effortless experience. Based in Gigabit Ethernet, this system platform is completely modular and infinitely expandable paving the way for an impressive range of future possibilities. Routing and submixing of up to 128 channels enables virtually unlimited configurations.

The Hear Back PRO System: Hub & Mixers

The Hear Back PRO system consists of two main components: the Hub and the Mixer. The modular Hub consists of 4 card slots, which can be populated with input and/or output cards – **Analog, ADAT, Dante, Waves SoundGrid, AES/EBU, Network, Virtual Mixer, or Word Clock** – for **over 840 different configurations** that fit to your exact needs.

Each Hub has the ability to supply signal and power to as many as 32 Mixers (8 per Network Card), each over a single standard CAT6* cable. And with the built-in HBUS In/Out ports, multiple Hubs can be daisy-chained together, allowing for truly unlimited system expansion.

The **Hear Back PRO** boasts many key advantages, including:

- Side-mounted card slot on Mixer for future expansion
- Large master knob controls overall main mix, AUX, and intercom levels independently
- Volume and panning control of all channels
- Direct and immediate visual feedback of all channels
- Support for sampling rates up to 192 kHz
- Selectable XLR or 1/8" Mixer AUX input
- Built-in intercom broadcasts the AUX source (mic, MP3 player, click, etc.)
- Intercom auto adjusts its own level so even the quietest message never goes unheard
- Modular I/O Hub card system lets you customize the system to match your configuration
- Supports secondary power supply to provide redundancy and power to up to 32 Mixers per Hub Mainframe
- USB port on Hub makes updating firmware for future features and upgrades a simple drag-and-drop operation
- HBUS In/Out connections allow daisy-chaining Hubs and a wireless access point connection for use with the iOS App
- Status indicating logos on Hub and Mixers make it easy to detect and diagnose problems, should they arise
- Write session info and channel settings on storable Mixer overlays for an unlimited number of presets
 - Instantly store and recall presets from memory with the push of a button
 - Most recent configuration is saved, even after power-down
- Hear Back PRO iOS App allows for complete control of all Hubs and Mixers connected to the network



hear back PRO

Hub Features:

- Three switch selectable 16-channel input sources:
 - Input A (Slots 1 & 2)
 - Input B (Slots 3 & 4)
 - HBUS
- 24-bit Delta-Sigma A/D converters
- Six user-selectable sample rates, indicated by LEDs: 44.1 kHz, 48 kHz, 88.2 kHz, 96 kHz, 176.4 kHz, and 192 kHz
- Less than .25 milliseconds total system delay (latency) at 192 kHz
- 16 RGB LEDs intuitively display signal / peak levels for channel metering
- Standard CAT6* delivers power and signals to Mixers
- Daisy-chain via HBUS for very large systems
- 1 RU chassis
- Modular I/O card-slot configurable mainframe
- Gigabit Ethernet network fabric, with enough bandwidth to support up to 96 channels of audio at 192/176.4 kHz, 128 channels at 96/88.2 kHz or 48/44.1 kHz.
- 48 volt Power Over Ethernet supply
- Port for redundant power supply (or to power more than 16 Mixers)
- USB port for firmware upgrades

Mixer Features:

- Local control of all available audio channels
- Receive power and audio over one Ethernet cable, up to 500' from Hub to each Mixer
- Large master knob controls overall main mix, AUX, and intercom levels independently
- 24-bit D/A and A/D delta-sigma converters
- Volume / panning / stereo link control of all channels of audio
- Balanced mono/stereo, line level outputs
- Store up to 4 recallable presets, plus preset copy and paste
- Multiple intercom feature
- Selectable 1/8 inch TRS stereo unbalanced and XLR mono balanced (with 15V phantom power) AUX inputs
- 1/8" and 1/4" TRS headphone outputs
- iOS App Compatibility

*Cable complying with the National authorities (cable with an outer jacket or sleeving rated VW-1 or better).



Hear Back PRO is proudly designed & assembled
in the U.S.A. by musicians and audio engineers.

hear back PRO | mixer

- 1 - LED Status Indicator
- 2 - LED Level Indicators
- 3 - Volume/Pan Control Knob for Each Audio Channel
- 4 - "Intercom" Button
- 5 - "Preset" Button
- 6 - "Master" Control Knob (Volume / Aux)
- 7 - "Aux" Input Button
- 8 - "Pan" Button
- 9 - Auxiliary 1/8" Stereo Unbalanced Audio Input
- 10 - Auxiliary Input Switch
- 11 - Auxiliary Balanced XLR Microphone Input with 15V Phantom Power
- 12 - 1/4" Left/Mono and Right Outputs (Balanced)
- 13 - 1/8" TRS Headphone Output
- 14 - 1/4" TRS Headphone Output
- 15 - Gigabit Ethernet (GbE) Connection with PoE+ (Power over Ethernet)



TOP



BOTTOM



hear back PRO | hub

- 1 - LED Status Indicator
- 2 - Sample Rate LED Indicators
- 3 - Audio Input Channels 1-16 Level LED Metering
- 4 - Input Selector Switch
- 5 - Power Switch
- 6 - "Dual" Power LED Indicator
- 7 - Main 48V Power Input
- 8 - Secondary 48V Power Input
- 9 - HBUS Input
- 10 - HBUS Output
- 11 - USB Connection
- 12 - Card Slot 1
- 13 - Card Slot 2
- 14 - Card Slot 3
- 15 - Card Slot 4

FRONT PANEL

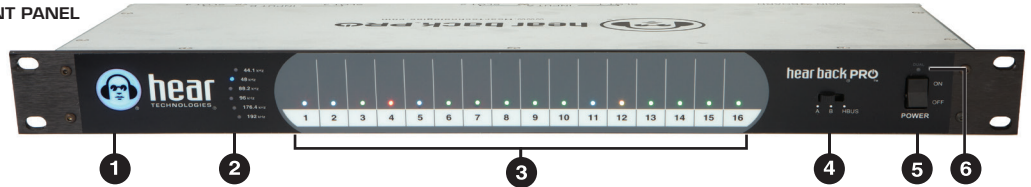

REAR PANEL



Hook-up Diagram | Analog

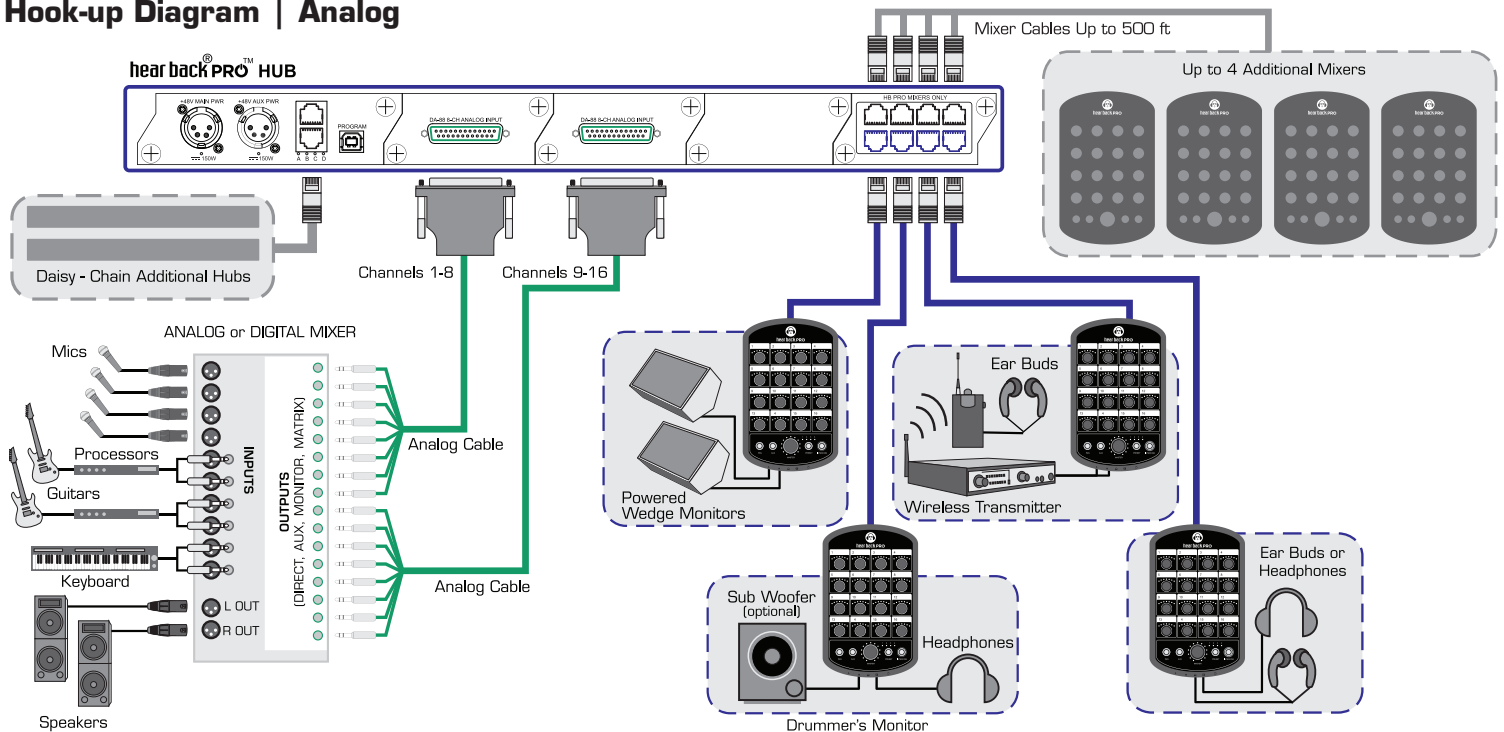

Modular I/O Cards

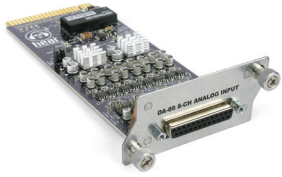

Analog Card

(8) Balanced audio inputs using standard Tascam DA-88-style pin-out DB25 connector



ADAT Card

(2) Optical ADAT TOS-Link ins
(2) Optical ADAT TOS-Link outs
(2) RJ45 HearBus outs



Dante Card

Connects 16 channels of simultaneous audio input/output with Dante-enabled equipment



Waves SoundGrid Card

Connects 16 channels of simultaneous audio in/out with SoundGrid-enabled equipment

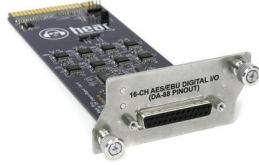

AES/EBU Card

DB25 to (8) XLR (each AES/EBU XLR Mono, balanced, 150 ohms digital audio)



Network Card

(8) RJ45 gigabit Ethernet ports for connecting PRO Mixers, PRO Distros, or other PRO Hubs

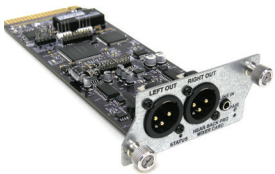

Virtual Mixer Card

All the features of the PRO Mixer in a card format controlled via iOS device or another PRO Mixer



Word Clock Card

Precise external system clock automatically detects sampling rate with BNC in/out connections



MADI Card (Coming Soon)

Optical and Coaxial MADI ins/outs connect 32 channels with PRO Hub and 64 channels with WSG Bridge

Hear Back PRO iOS App

New streamlined interface for controlling Hear Back PRO Hubs and Mixers with your wireless device.



Scan code to download from iTunes or search app store for "Hear Back PRO"



Technical Specifications

Mixer Aux Input

Line Input Configuration/Impedance: 1/8" Stereo, unbalanced, 10K ohms typical
Line Input Level: 0 dBu optimal, +18 dBu max
Mic Input Configuration/Impedance: XLR Mono, balanced, 150 ohms typical, 150 Hz high pass
Mic Input Level: -42 dBu optimal, -30 dBu max

Mixer Headphone Power

Load Impedance:	THD less than 0.01%*	THD less than 0.1%
8 Ohms:	1.2 W*	1.5 W
	*THD AT 8 Ohms = 0.015% typical	
16 Ohms:	1.6 W	1.8 W
25 Ohms:	2.0 W	2.2 W
32 Ohms:	1.8 W	2.0 W
50 Ohms:	1.5 W	1.6 W
100 Ohms:	1.1 W	1.2 mW
200 Ohms:	500 mW	650 mW
600 Ohms:	220 mW	250 mW

Inter Modulation Distortion: Typically less than 0.03%

Mixer Line Output

Frequency Response: 20 Hz to 20 kHz, +/-0.15 dB
THD+N: 0.004% typical at 1 kHz, +15 dBu
0.008% typical, 20 Hz - 20 kHz, +4 dBu
Inter Modulation Distortion: 0.02% typical at +4 dBu, 60 Hz / 7 kHz
Crosstalk: Less than -93 dB @ 1 kHz
Propagation Delay:
Analog Input to Analog Output: 0.248 mSec @ 192 kHz sample rate
Digital Input to Analog Output: 0.092 mSec @ 192 kHz sample rate
Digital Input to Digital Output: 0.0452 mSec @ 192 kHz sample rate
Audio over Ethernet Protocol (HBUS): 0.000592 mSec

System Noise Performance

Noise, A-Weighted: -93 dBu @ 192 kHz sample rate
Dynamic Range: 117 dB typical

Note: 0 dBu = 0.775 Vrms. Specifications and features subject to change without notice.
**Cable complying with the National authorities (cable with an outer jacket or sleeving rated VW-1 or better).
***Hub is capable of powering up to 32 Mixers with an additional power supply.

System I/O

Hub Line In, Analog: 8 balanced inputs on a DB-25 female (DA-88 pinout) per Analog Card
Hub Maximum Input Level, Analog: +2 dBu with analog card pad jumpers populated, +12dBu with jumpers removed (up to +38dBu upon special request)
Hub HBUS In, Out: 8-pin RJ45 jack (standard Ethernet pinout)
Hub USB Port: USB 2.0 (for firmware updates)
Hub Card Slots (4x): Each slot can accept an analog or digital input card, output card, or 8-port Mixer network card
Mixer to Hub Connection: 8-pin RJ45 jack (8x Mixer connections per network card)
Mixer Headphone Out: 1x TRS 1/4" and 1x TRS 1/8" unbalanced stereo
Mixer Line Out: 2x TRS 1/4" balanced (left/mono and right)
Mixer Max Output Level, Analog: +24 dBu (mixed output)
Mixer Aux Input: 1x TRS 1/8" unbalanced stereo and 1x XLR balanced mono (with 15 volts phantom power)
Mixer Card Slot: For future digital or analog input/output expansion capabilities or side-car add-on

Physical, Mixer

Size: 9.5" (241 mm) H x 5.95" (151 mm) W x 2.71" (69 mm) D
Unit Weight: 1.6 lb. (0.72 kg)
Mounting: Standard mic stand (5/8" 27 threads per inch) or desk mounted

Physical, Hub

Size: 1.75" (45 mm) H x 19" (483 mm) W x 8.5" (216 mm) D
Unit Weight: 6.3 lb. (2.8 kg)
Mounting: Standard rack mount, 1 RU

Power

Hub Power Requirements: 48VDC, 150 Watts (each external power supply powers up to 16 Mixers)***
Mixer Power Requirements: Power over Ethernet (PoE) 36-52 volts DC, 15 Watts max provided by Hub through CAT6** network cabling

External Power Supply Requirements: Input Voltage: 90VAC to 264VAC 50/60 Hz

Cabling, Mixers and HBUS

CAT6** cables used for Mixers or for HBUS can be run up to 500 feet in ideal conditions (one piece of solid conductor CAT6 with no breaks or couplings). The more breaks/connections/couplings in a cable run, the more limited this distance will be. Poor quality cabling will also limit the maximum distance.



Hear Technologies®
991 Discovery Drive
Huntsville, AL 35806

www.HearTechnologies.com
Phone: 1-256-922-1200
Fax: 1-256-922-1221

Printed in U.S.A. ©2020
Apr 2020