

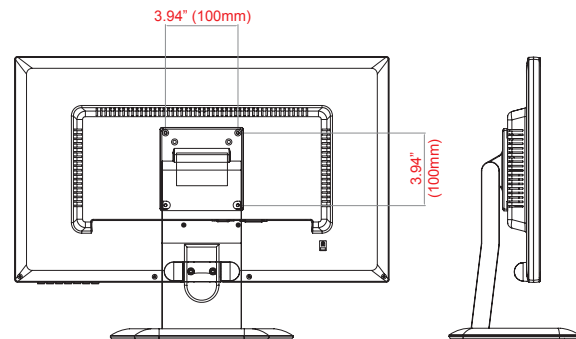

MODEL #	VZ-215iPM
DISPLAY	
Screen Size	21.5"
Max. Resolution	1920 x 1080 @60 Hz pixel
Pixel Pitch	0.248 mm x 0.248 mm
Brightness	250cd/m ² (Typical)
Contrast Ratio	1000 : 1
Aspect Ratio	16 : 9
Viewing Angle (H/V)	170° / 160°
Display Color	16.7 Million
Response Time	< 5 ms
Frequency (H)	31 ~ 80Khz
Frequency (V)	50 ~ 75Hz
INTERFACE	
Ethernet 10/100	1
USB 2.0	2
Micro USB	1
PGM (Manufacture Only)	1
Micro SD	1
ANDROID BOARD SPEC	
Android OS	Ver. 5.1.1.
CPU	RK3368 64bit Octa core Cortex A53
RAM	2GB DDR3
Storage	8GB (Nand-Flash)
External Storage	Micro SD up to 32GB / USB 2.0 up to 2TB
Support Video File Format	MKV,WMV/VC-1 SP/MP/AP,MPG,MPEG, AVI,MOV,MP4,RM,H.264,dat,RV 8/9/10
Support Video Codec	H.264, MPEG4, RMBV, Xvid, Divx, H.264, VP8, WMV, HTML, FLASH
Support Image File Format	JPG, JPEG, MJPEG, PNG
SPECIAL FEATURES	
Sequential Viewing Mode	Available
Multi Channel Viewing Modes	1 / 2 / 3 / 4 / 6 / 9
WEIGHT & DIMENSIONS	
Outline Dimension (W x H x D) (inch)	20.28 x 15.375 x 7.25
(W x H x D) (mm)	515 x 390 x 184
Net Weight / Gross Weight	4.31 Kg (9.50 lbs) / 5.68 Kg (12.52 lbs)
MOUNT	
VESA	100 mm x 100 mm / M4 x 10 mm
GENERAL	
Transmitter - IR Remote Control	Yes
Power - Electrical Ratings	DC 12V, 3.3A(AC100 ~ 240V[50/60Hz])
Warranty - Parts / Labor	3 Year / 3 Year
- MTBF (Approx.)	50,000 Hours
Operating Temperature	32 - 140°F / 0 - 60°C
Multi-lingual Language	English, German, Spanish, French, Italian, Portuguese, Netherlander, Russian
Compatible Mounts - WALL	VZ-WM05, VZ-WM11, VZ-AM01
- RACK	VZ-RMK 08

VZ-215iPM ADVANTAGES

- 21.5" LED Grade **A** Commercial Panel
- Full HD 1080p Resolution
- Ethernet 10/100
- Built-in Android OS
- Cost-Effective Alternative to Remote Viewing PC
- Designed to Run Android Apps
- ViewZ App **Supports Over 8,000 IP Camera Models**
- **Sequential & 9 Cameras Viewing Modes** Available (via ViewZ App)

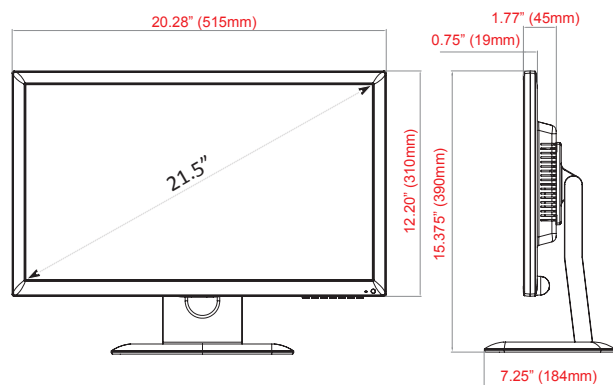

INTERFACE



1. PGM (Service Port)
2. DC 12V In
3. MICRO SD
4. USB 2.0 x 2ea
5. Micro USB
6. ETHERNET 10/100 (RJ 45)

Contact ViewZ

- Address : 177 W. Orangethorpe Ave., Placentia, CA 92870
- Phone : (714) 996-1177, Fax : (714) 996-1138
- Sales : sales@viewzusa.com
- Specification subject to change without notice.