

# F80 series

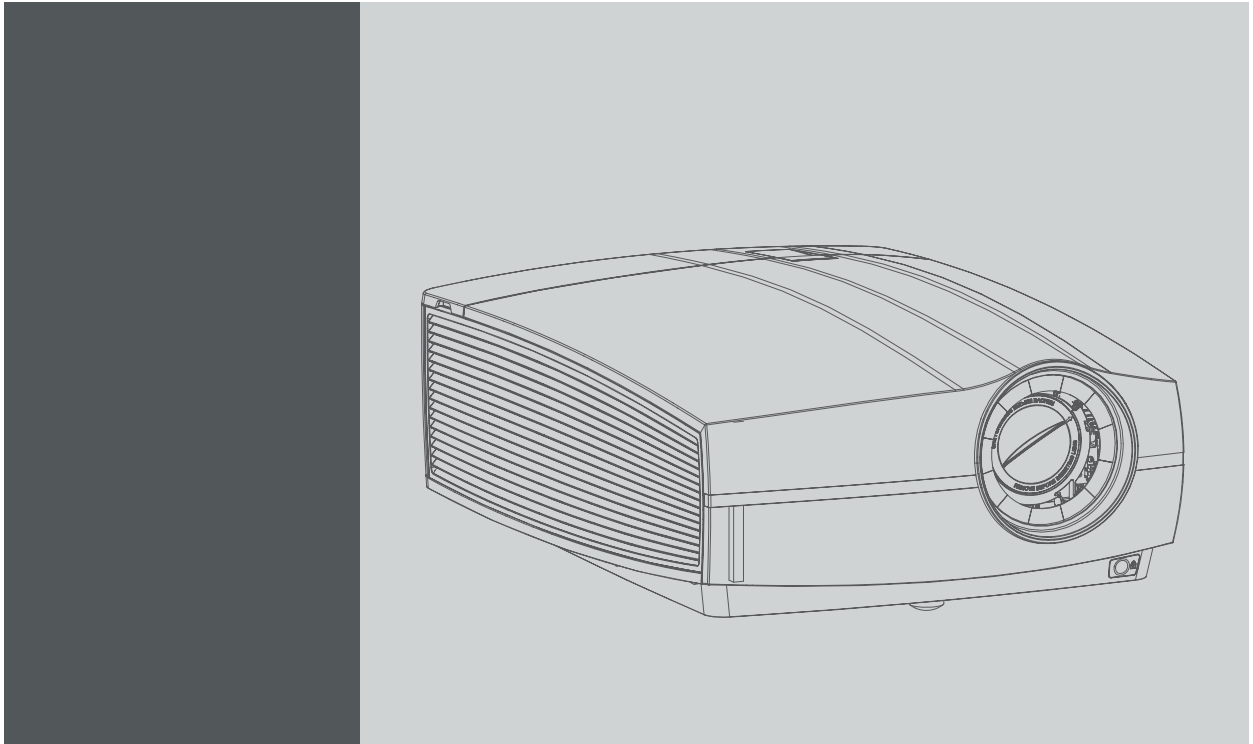

## User Manual

**Registered address: Barco NV**

President Kennedypark 35, 8500 Kortrijk, Belgium

Phone: +32 56.23.32.11

Fax: +32 56.26.22.62

Support: [www.barco.com/en/support](http://www.barco.com/en/support)

Visit us at the web: [www.barco.com](http://www.barco.com)

**Barco Fredrikstad AS**

Habornveien 53, N-1630 Gamle Fredrikstad, Norway

Phone: +47 6930 4550

Fax: +47 6930 4580

Support: [Support.fre@barco.com](mailto:Support.fre@barco.com)

Visit us at the web: [www.barco.com](http://www.barco.com)

## Copyright ©

All rights reserved. No part of this document may be copied, reproduced or translated. It shall not otherwise be recorded, transmitted or stored in a retrieval system without the prior written consent of Barco.

## Changes

Barco provides this manual 'as is' without warranty of any kind, either expressed or implied, including but not limited to the implied warranties or merchantability and fitness for a particular purpose. Barco may make improvements and/or changes to the product(s) and/or the program(s) described in this publication at any time without notice.

This publication could contain technical inaccuracies or typographical errors. Changes are periodically made to the information in this publication; these changes are incorporated in new editions of this publication.

The latest edition of Barco manuals can be downloaded from the Barco web site [www.barco.com](http://www.barco.com) or from the secured Barco web site <https://www.barco.com/en/signin>.

## Trademarks

Brand and product names mentioned in this manual may be trademarks, registered trademarks or copyrights of their respective holders. All brand and product names mentioned in this manual serve as comments or examples and are not to be understood as advertising for the products or their manufacturers.

## Guarantee and Compensation

Barco provides a guarantee relating to perfect manufacturing as part of the legally stipulated terms of guarantee. On receipt, the purchaser must immediately inspect all delivered goods for damage incurred during transport, as well as for material and manufacturing faults Barco must be informed immediately in writing of any complaints.

The period of guarantee begins on the date of transfer of risks, in the case of special systems and software on the date of commissioning, at latest 30 days after the transfer of risks. In the event of justified notice of complaint, Barco can repair the fault or provide a replacement at its own discretion within an appropriate period. If this measure proves to be impossible or unsuccessful, the purchaser can demand a reduction in the purchase price or cancellation of the contract. All other claims, in particular those relating to compensation for direct or indirect damage, and also damage attributed to the operation of software as well as to other services provided by Barco, being a component of the system or independent service, will be deemed invalid provided the damage is not proven to be attributed to the absence of properties guaranteed in writing or due to the intent or gross negligence or part of Barco.

If the purchaser or a third party carries out modifications or repairs on goods delivered by Barco, or if the goods are handled incorrectly, in particular if the systems are operated incorrectly or if, after the transfer of risks, the goods are subject to influences not agreed upon in the contract, all guarantee claims of the purchaser will be rendered invalid. Not included in the guarantee coverage are system failures which are attributed to programs or special electronic circuitry provided by the purchaser, e.g. interfaces. Normal wear as well as normal maintenance are not subject to the guarantee provided by Barco either.

The environmental conditions as well as the servicing and maintenance regulations specified in this manual must be complied with by the customer.

## Federal Communications Commission (FCC Statement)

This equipment has been tested and found to comply with the limits for a class A digital device, pursuant to Part 15 of the FCC rules. These limits are designed to provide reasonable protection against harmful interference when the equipment is operated in a commercial environment. This equipment generates, uses, and can radiate radio frequency energy and, if not installed and used in accordance with the instruction manual, may cause harmful interference to radio communications. Operation of this equipment in a residential area may cause harmful interference, in which case the user will be responsible for correcting any interference at his own expense

Changes or modifications not expressly approved by the party responsible for compliance could void the user's authority to operate the equipment

## EMC statements

### EN55032/CISPR32 Class A MME (MultiMedia Equipment)

**Warning :** This equipment is compliant with Class A of CISPR 32. In a residential environment this equipment may cause radio interference.

### Class A ITE (Information Technology Equipment)

**Warning :** This is a class A product. In a domestic environment this product may cause radio interference in which case the user may be required to take adequate measures.





# TABLE OF CONTENTS

<b>1. Safety</b>	<b>3</b>
1.1 General considerations	3
1.2 Important safety instructions	4
1.3 Product safety labels	7
1.4 Risk Group 3 Safety	8
1.4.1 General considerations	8
1.4.2 High Brightness precautions: Hazard Distance (HD)	8
1.4.3 HD for fully enclosed projection systems	10
1.4.4 HD in function of the lens Throw Ratio (TR)	11
<b>2. Remote Control Unit</b>	<b>13</b>
2.1 Remote control, Battery installation	13
2.2 Using the XLR connector of the RCU	14
2.3 Remote control, on/off button	14
<b>3. Input &amp; Communication</b>	<b>17</b>
3.1 Introduction	17
3.2 Connection Panel	17
3.3 Making connections	18
3.4 Connector specifications	18
3.4.1 DVI-I	18
3.4.2 Display Port 1.2	19
3.4.3 HDMI 2.0	19
3.4.4 3G-SDI	19
3.4.5 HDBase T	20
3.5 Control interfaces	20
3.5.1 RS-232	20
3.5.2 LAN/Ethernet	21
3.5.3 USB-A port	21
3.6 LED and Button indication chart	21
<b>4. Getting Started</b>	<b>23</b>
4.1 Functionality overview	23
4.2 Power modes	24
4.3 Power mode transitions	25
4.3.1 General	25
4.3.2 Power on projector	25
4.3.3 Going from READY to ON	26
4.3.4 Going from ON to READY	26
4.3.5 Going from READY to ECO standby	26
4.3.6 Going from ECO to ON	26
4.4 Status overview	26
4.5 Power off projector	27
4.6 Operation in 24/7 Mode	27
4.7 Using the RCU	28
4.8 Projector Address	29
4.8.1 Controlling the projector	29
4.8.2 Displaying and Programming addresses into the RCU	30
4.9 Quick setup via Direct access	30
<b>5. Graphic User Interface (GUI)</b>	<b>33</b>
5.1 Overview	33
5.2 Navigation	33
5.3 Test Patterns	34
<b>6. GUI – Source</b>	<b>37</b>
6.1 Source Selection	37
6.2 Connector Settings	37
<b>7. GUI – Image</b>	<b>39</b>
7.1 Setting image levels manually	39
7.2 P7 Realcolor	40
7.3 HDR – Perceptual Quantizer (PQ)	41
<b>8. GUI – Installation</b>	<b>43</b>
8.1 Configuring the lens, shift	43
8.2 Orientation	43
8.3 Warping	44
8.3.1 About warping	44
8.3.2 Warping – On/Off	44
8.3.3 Warping – Screen Size	45
8.3.4 Warping – 4 corners adjustment	46
8.3.5 Warping – Bow	47

8.3.6	Warping – Warp files .....	49
8.4	Blending .....	50
8.4.1	Blend Zones .....	51
8.4.2	Black level adjustment .....	53
8.4.3	Black Level Files .....	54
8.4.4	Blend Files .....	55
8.5	Laser illumination .....	57
8.6	Active 3D Set up .....	57
<b>9.</b>	<b>GUI – System Settings .....</b>	<b>59</b>
9.1	Communication .....	59
9.1.1	Introduction to a Network connection .....	59
9.1.2	Wired IP address set up .....	60
9.2	Themes .....	61
9.3	Standby ECO .....	61
9.4	Service Menu .....	62
9.4.1	Service – Color Wheel .....	62
9.4.2	Service – Color .....	63
9.4.3	Service – Statistics .....	64
9.4.4	Lens Calibration .....	65
9.4.5	Lens features .....	66
9.4.6	Service – Pixel Shift .....	67
9.5	Reset .....	67
<b>10.</b>	<b>Status menu .....</b>	<b>71</b>
10.1	Status menu overview .....	71
<b>11.</b>	<b>Maintenance .....</b>	<b>73</b>
11.1	Cleaning the lens .....	73
11.2	Cleaning the exterior of the projector .....	73
11.3	Filters .....	73
<b>A.</b>	<b>Specifications .....</b>	<b>75</b>
A.1	Specifications of the F80-Q7 .....	75
A.2	Specifications of the F80-Q9 .....	75
A.3	Specifications of the F80-4K7 .....	76
A.4	Specifications of the F80-4K9 .....	76
A.5	Dimensions of a F80 .....	77
A.6	Technical Regulations .....	78
<b>B.</b>	<b>Environmental information .....</b>	<b>79</b>
B.1	Disposal information .....	79
B.2	China RoHS compliance .....	79
B.3	Taiwan RoHS compliance .....	80
B.4	Turkey RoHS compliance .....	81
B.5	Contact information .....	81
B.6	Product Info (Taiwan) .....	82

# 1. SAFETY

## About this document

Read this document attentively. It contains important information to prevent personal injury while installing and using the F80 projector. Furthermore, it includes several cautions to prevent damage to the F80 projector. Ensure that you understand and follow all safety guidelines, safety instructions and warnings mentioned in this chapter before installing the F80 projector.

## Clarification of the term “F80” used in this document

When referring in this document to the term “F80” means that the content is applicable for following Barco products:

- F80-Q7, F80-Q9, F80-4K7, F80-4K9, F80-Ultra

## Model certification name

- GPC

## 1.1 General considerations

### General safety instructions

- Before operating this equipment please read this manual thoroughly and retain it for future reference.
- Installation and preliminary adjustments should be performed by qualified Barco personnel or by authorized Barco service dealers.
- All warnings on the projector and in the documentation manuals should be adhered to.
- All instructions for operating and use of this equipment must be followed precisely.
- All local installation codes should be adhered to.

### Notice on safety

This equipment is built in accordance with the requirements of the international safety standards IEC60950-1, as basis for National safety regulation world wide. The safety standard covers information technology equipment including electrical business equipment intended to operate in “normal” environments (offices and homes). This safety standard imposes important requirements on the use of safety critical components, materials and insulation, in order to protect the user or operator against risk of electric shock and energy hazard and having access to live parts. Safety standards also impose limits to the internal and external temperature rises, radiation levels, mechanical stability and strength, enclosure construction and protection against the risk of fire. Simulated single fault condition testing reduce the risk of hazards and contribute to ensure the safety of the equipment to the user even when the equipment’s normal operation fails.

### Notice on optical radiation

This projector embeds extremely high brightness (radiance) lasers; this laser light is processed through the projectors optical path. Native laser light is not accessible by the end user in any use case. The light exiting the projection lens has been diffused within the optical path, representing a larger source and lower radiance value than native laser light. Nevertheless the projected light represents a significant risk for the human eye when exposed directly within the beam. This risk is not specific related to the characteristics of laser light but solely to the high thermal induced energy of the light source; which is equivalent with lamp based systems.

Thermal retinal eye injury is possible when exposed within the Hazard Distance (HD). The HD is defined from the projection lens surface towards the position of the projected beam where the irradiance equals the maximum permissible exposure as described in the chapter “Hazard Distance”.

### Notice on optical radiation (addendum)

- F80-Ultra, F80-Q9, F80-4K9 :
  - The projector is Class 1 laser product that conforms with IEC EN 60825-1:2014. The projector conforms with IEC 60825-1:2007, and with performance standards for laser products under 21 CFR 1040, except with respect to those characteristics authorized by Variance Number 2017-V-4837 effective September 13, 2017 Do not stare into Beam.
  - This projector is Risk Group 2 (RG2) according to IEC EN 62471-5. This projector may become Risk Group 3 (RG3) when an interchangeable lens with throw ratio greater than 2.8 is installed. For Northern America, installation requirements according to Risk group 3 (RG3) must be followed when interchangeable lens with throw ratio greater than 2.0 is installed. Refer to the manual for the lens list and throw ratio before operation. Such combination of projector and lens are intended for professional use only, and are not intended for consumer use. Safety considerations for RG3 projectors are discussed in section "Risk Group 3 Safety", page 8 .
  - This projector has one or several built-in Class 4 laser clusters. Disassembly or modification is very dangerous and should never be attempted.

## 1. Safety

---

- F80-Q7, F80-4K7 :
  - The projector is Class 1 laser product that conforms with IEC EN 60825-1:2014. The projector conforms with IEC 60825-1:2007, and with performance standards for laser products under 21 CFR 1040, except with respect to those characteristics authorized by Variance Number 2017-V-4837 effective September 13, 2017 Do not stare into Beam.
  - This projector is Risk Group 2 (RG2) according to IEC EN 62471-5. This projector may become Risk Group 3 (RG3) when an interchangeable lens with throw ratio greater than 3.5 is installed. For Northern America, installation requirements according to Risk group 3 (RG3) must be followed when interchangeable lens with throw ratio greater than 2.0 is installed. Refer to the manual for the lens list and throw ratio before operation. Such combination of projector and lens are intended for professional use only, and are not intended for consumer use. Safety considerations for RG3 projectors are discussed in section "Risk Group 3 Safety", page 8 .
  - This projector has one or several built-in Class 4 laser clusters. Disassembly or modification is very dangerous and should never be attempted.

### Users definition

Throughout this manual, the term SERVICE PERSONNEL refers to Barco authorized persons having appropriate technical training and experience necessary to be knowledgeable of potential hazards to which they are exposed (including, but not limited to HIGH VOLTAGE ELECTRIC and ELECTRONIC CIRCUITRY and HIGH BRIGHTNESS PROJECTORS) in performing a task, and of measures to minimize the potential risk to themselves or other persons. Only Barco authorized SERVICE PERSONNEL, knowledgeable of such risks, are allowed to perform service functions inside the product enclosure. The term USER and OPERATOR refers to any person other than SERVICE PERSONNEL. When installing an interchangeable lens with a throw ratio that make the projector become RG3, refer to chapter "Risk Group 3 Safety", page 8 . Such combination of projector and lens are intended for professional use only, and are not intended for consumer use.

FOR PROFESSIONAL USE ONLY means installation can only be carried out by Barco AUTHORIZED PERSONNEL familiar with potential hazards associated with high intensity light beams.

## 1.2 Important safety instructions

---

### To prevent the risk of electrical shock

- This product should be operated from a mono phase AC power source.
- This apparatus must be grounded (earthed) via the supplied 3 conductor AC power cable. If none of the supplied power cables are the correct one, consult your dealer. If you are unable to insert the plug into the outlet, contact your electrician to replace your obsolete outlet. Do not defeat the purpose of the grounding-type plug. Never use 2-prong power cords, as this is dangerous and could lead to electrical shock.
- Do not allow anything to rest on the power cord. Do not locate this product where persons will walk on the cord. To disconnect the cord, pull it out by the plug. Never pull the cord itself.
- Use only the power cord supplied with your device. While appearing to be similar, other power cords have not been safety tested at the factory and may not be used to power the device. For a replacement power cord, contact your dealer.
- Do not operate the projector with a damaged cord. Replace the cord.
- Do not operate the projector if the projector has been dropped or damaged - until it has been examined and approved for operation by qualified service personnel.
- Position the cord so that it will not be tripped over, pulled, or contact hot surfaces.
- If an extension cord is necessary, a cord with a current rating at least equal to that of the projector should be used. A cord rated for less amperage than the projector may overheat.
- Never push objects of any kind into this product through cabinet slots as they may touch dangerous voltage points or short out parts that could result in a risk of fire or electrical shock.
- Make sure that no objects enter into the vents and openings of the set.
- Do not expose this projector to rain or moisture.
- The projector is designed for indoor use only. Never operate the unit outdoors.
- Do not immerse or expose this projector in water or other liquids.
- Do not spill liquid of any kind on this projector.
- Should any liquid or solid object fall into the cabinet, unplug the set and have it checked by qualified service personnel before resuming operations.
- Do not disassemble this projector, always take it to qualified service personnel when service or repair work is required.
- Do not use an accessory attachment which is not recommended by the manufacturer.
- Lightning - For added protection for this video product during a lightning storm, or when it is left unattended and unused for long periods of time, unplug it from the wall outlet. This will prevent damage to the device due to lightning and AC power-line surges.

## To prevent personal injury

- To prevent injury and physical damage, always read this manual and all labels on the system before powering the projector or adjusting the projector.
- To prevent injury, take note of the weight of the projector. Minimum 2 persons are needed to carry the projector. The projector weights about  $\pm 26$  kg ( $\pm 57$  lbs) without lens and rigging frame.
- To prevent injury, ensure that the lens and all covers are correctly installed. See installation procedures.
- Warning: high intensity light beam. NEVER look into the lens ! High luminance could result in damage to the eye.
- **Warning: extremely high brightness projector:** This projector embeds extremely high brightness (radiance) lasers; this laser light is processed through the projector's optical path. Native laser light is not accessible by the end user in any use case. The light exiting the projection lens has been diffused within the optical path, representing a larger source and lower radiance value than native laser light. Nevertheless the projected light represents a significant risk for the human eye when exposed directly within the beam. This risk is not specific related to the characteristics of laser light but solely to the high thermal induced energy of the light source; which is comparable with lamp based systems.  
Thermal retinal eye injury is possible when exposed within the Hazard Distance. The Hazard Distance (HD) is defined from the projection lens surface towards the position of the projected beam where the irradiance equals the maximum permissible exposure as described in the chapter "High Brightness precautions: Hazard Distance (HD)", page 8 .
- Based on international requirements, no person is allowed to enter the projected beam within the zone between the projection lens and the related Hazard Distance (HD). This shall be physically impossible by creating sufficient separation height or by placing optional barriers. Within the restricted area operator training is considered sufficient. The applicable separation heights are discussed in "High Brightness precautions: Hazard Distance (HD)", page 8 .
- Don't put your hand in front of the beam.
- This product contains no user serviceable parts. Attempts to modify/replace mechanics or electronics inside the housing or compartments will violate any warranties and may be hazardous.
- A special device ("rigged frame") based on an external frame must be used when the projector is deployed in a hanging configuration, or when several projectors must be stacked. See installation manuals for the correct use of these devices.
- Do not place this equipment on an unstable cart, stand, or table. The product may fall, causing serious damage to it and possible injury to the user.
- It is hazardous to operate without lens or shield. Lenses, shields or ultra violet screens shall be changed if they have become visibly damaged to such an extent that their effectiveness is impaired. For example by cracks or deep scratches.
- **Cooling liquid circuit.** The projector contains a cooling circuit filled with Green Ethylene glycol diluted (53% Glycol – 47% Demi water). When the cooling circuit leaks, switch off the device and contact qualified service personnel. The liquid is not for household use. Keep out of reach of children. Harmful by oral intake. Avoid exposure to pregnant women. Avoid contact with eyes, skin and clothing. Avoid inhale of the noxious fumes.
- Never point or allow light to be directed on people or reflective objects within the HD zone.
- All operators shall have received adequate training and be aware of the potential hazards.
- In case of using an external cooling system position the hoses of the cooling system so that they will not be tripped over, pulled, or contact hot surfaces.

## To prevent fire hazard

- Do not place flammable or combustible materials near the projector!
- Barco projection products are designed and manufactured to meet the most stringent safety regulations. This projector radiates heat on its external surfaces and from ventilation ducts during normal operation, which is both normal and safe. Exposing flammable or combustible materials into close proximity of this projector could result in the spontaneous ignition of that material, resulting in a fire. For this reason, it is absolutely necessary to leave an "exclusion zone" around all external surfaces of the projector whereby no flammable or combustible materials are present. The exclusion zone in the exhaust area must be not less than 100 cm (40"). The exclusion zone on the intake area must be not less than 50 cm (20").
- Do not place any object in the projection light path at close distance to the projection lens output. The concentrated light at the projection lens output may result in damage, fire or burn injuries.
- Do not cover the projector or the lens with any material while the projector is in operation. Keep flammable and combustible materials away from the projector at all times. Mount the projector in a well ventilated area away from sources of ignition and out of direct sun light. Never expose the projector to rain or moisture. In the event of fire, use sand, CO<sub>2</sub> or dry powder fire extinguishers. Never use water on an electrical fire. Always have service performed on this projector by authorized Barco service personnel. Always insist on genuine Barco replacement parts. Never use non-Barco replacement parts as they may degrade the safety of this projector.
- Ensure no misalignment can occur. Prolonged exposure of wooden walls at close distance (< 20 cm) can represent a fire risk. After alignment the projector shall be securely mounted to the pedestal.
- Slots and openings in this equipment are provided for ventilation. To ensure reliable operation of the projector and to protect it from overheating, these openings must not be blocked or covered. The openings should never be blocked by placing the projector too close to walls, or other similar surface. This projector should never be placed near or over a radiator or heat register. This projector should not be placed in a built-in installation or enclosure unless proper ventilation is provided.
- Projection rooms must be well ventilated or cooled in order to avoid build up of heat. It is necessary to vent hot exhaust air from projector and cooling system to the outside of the building.
- Let the projector cool completely before storing. Remove cord from the projector when storing.

### To prevent projector damage

- Always remove lens cap before switching on the projector. If the lens cap is not removed, it may melt due to the high energy light emitted through the lens. Melting the lens cap may permanently damage the surface of the projection lens.
- The air filters of the projector must be cleaned or replaced on a regular basis. Cleaning the booth area would be monthly-minimum. Neglecting this could result in disrupting the air flow inside the projector, causing overheating. Overheating may lead to the projector shutting down during operation.
- The projector must always be installed in a manner which ensures free flow of air into its air inlets.
- If more than one projector is installed in a common projection booth, the exhaust air flow requirements are valid for EACH individual projector system. Note that inadequate air extraction or cooling will result in decreased life expectancy of the projector as a whole as well as causing premature failure of the lasers.
- In order to ensure that correct airflow is maintained, and that the projector complies with Electromagnetic Compatibility (EMC) and safety requirements, it should always be operated with all of its covers in place.
- Slots and openings in the cabinet are provided for ventilation. To ensure reliable operation of the product and to protect it from overheating, these openings must not be blocked or covered. The openings should never be blocked by placing the product on a bed, sofa, rug, or other similar surface. This product should never be placed near or over a radiator or heat register. The device should not be placed in a built-in installation or enclosure unless proper ventilation is provided.
- Ensure that nothing can be spilled on, or dropped inside the projector. If this does happen, switch off and remove all power from the projector. Do not operate the projector again until it has been checked by qualified service personnel.
- Do not block the projector cooling fans or free air movement around the projector.
- Do not use this equipment near water.
- **Special care for Laser Beams:** Special care should be used when DLP projectors are used in the same room as high power laser equipment. Direct or indirect hitting of a laser beam on to the lens can severely damage the Digital Mirror Devices™ in which case there is a loss of warranty.
- Never place the projector in direct sunlight. Sunlight on the lens can severely damage the Digital Mirror Devices™ in which case there is a loss of warranty.
- Save the original shipping carton and packing material. They will come in handy if you ever have to ship your equipment. For maximum protection, repack your set as it was originally packed at the factory.
- Unplug this product from the wall outlet before cleaning. Do not use liquid cleaners or aerosol cleaners. Use a damp cloth for cleaning. Never use strong solvents, such as thinner or benzine, or abrasive cleaners, since these will damage the cabinet. Stubborn stains may be removed with a cloth lightly dampened with mild detergent solution.
- To ensure the highest optical performance and resolution, the projection lenses are specially treated with an anti-reflective coating, therefore, avoid touching the lens. To remove dust on the lens, use a soft dry cloth. For lens cleaning follow the instructions precisely as stipulated in the projector manual.
- Only connect the projector to signal sources and voltages as described in the technical specification. Connecting to unspecified signal sources or voltages may lead to malfunction and permanent damage of the unit.
- Allowed ambient temperature range:  $t_a = 10^{\circ}\text{C}$  (50°F) to  $40^{\circ}\text{C}$  (104°F)
- Rated humidity = 20% RH to 80% RH Non-condensed.
- Do not operate the projector outside its temperature and humidity specifications as this may result in overheating and malfunction.

### On servicing







- Do not attempt to service this product yourself. This product contains no user serviceable parts except parts describe in the User manual. Attempts to modify/replace mechanics or electronics inside the housing or compartments will violate any warranties and may expose you to dangerous voltage potentials, risk of electric shock and retinal eye injury.
- Refer all servicing to Barco authorized repair centers.
- Attempts to alter the factory-set internal controls or to change other control settings not specially discussed in this manual can lead to permanent damage to the projector and cancellation of the warranty.
- Remove all power from the projector and refer servicing to Barco authorized repair center under the following conditions:
  - When the power cord or plug is damaged or frayed.
  - If liquid has been spilled into the equipment.
  - If the product has been exposed to rain or water.
  - If the product does not operate normally when the operating instructions are followed. Adjust only those controls that are covered by the operating instructions since improper adjustment of the other controls may result in damage and will often require extensive work by a qualified technician to restore the product to normal operation.
  - If the product has been dropped or the cabinet has been damaged.
  - If the product exhibits a distinct change in performance, indicating a need for service.
- Replacement parts: When replacement parts are required, be sure the service technician has used original Barco replacement parts or authorized replacement parts which have the same characteristics as the Barco original part. Unauthorized substitutions may result in degraded performance and reliability, fire, electric shock or other hazards. Unauthorized substitutions may void warranty.
- Safety check: Upon completion of any service or repairs to this projector, ask the service technician to perform safety checks to determine that the product is in proper operating condition.

## Safety Data Sheets for Hazardous Chemicals

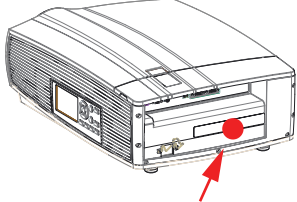
For safe handling information on chemical products, consult the Safety Data Sheet (SDS). SDSs are available upon request via [safetydatasheets@barco.com](mailto:safetydatasheets@barco.com).

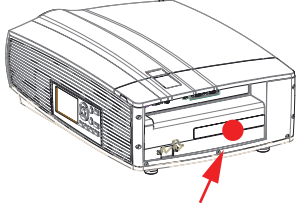
### 1.3 Product safety labels

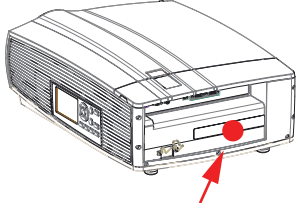
#### Light beam related safety labels

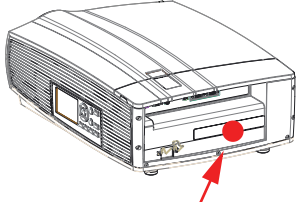
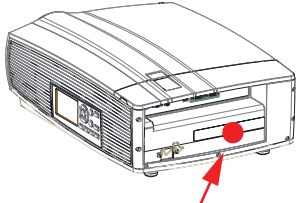
Label image	Label description	Label location
	Refer to user manual for further information!	
	Caution! Do not stare into beam, RG2 product.	
	Hazard RG3: not for household use symbol.	
	Hazard RG3: optical radiation warning symbol.	
<p><b>For F80-Q7, F80-4K7:</b></p> <div style="border: 2px solid black; padding: 5px;"> <p>For North America: THIS PRODUCT IS IN CONFORMITY WITH PERFORMANCE STANDARDS FOR LASER PRODUCTS UNDER 21 CFR 1040, EXCEPT WITH RESPECT TO THOSE CHARACTERISTICS AUTHORIZED BY VARIANCE NUMBER 2017-V-4837 EFFECTIVE SEPTEMBER 13, 2017.</p> <p>This projector may become RG3 when an interchangeable lens with throw ratio greater than 3.5 is installed. Refer to the manual for the lens list and hazard distance before operation. Such combinations of projector and lens are intended for professional use only, and are not intended for consumer use.</p> <p>Ce projecteur peut devenir un projecteur RG3 en cas d'installation d'un objectif interchangeable dont le rapport de projection est supérieur à 3.5. Veuillez vous reporter au manuel pour en savoir plus sur la liste des objectifs et la distance de sécurité avant toute utilisation. De telles combinaisons entre projecteur et objectif sont conçues pour des applications professionnelles uniquement et pas pour des applications grand public.</p> <p>本投影机安装投射比大于3.5的可换镜头后,可成为RG3,操作前,请参考手册中镜头清单和危险距离。本投影机与镜头组合仅供专业使用,非普通消费者使用。</p> </div>		

For North America: THIS PRODUCT IS IN CONFORMITY WITH PERFORMANCE STANDARDS FOR LASER PRODUCTS UNDER 21 CFR 1040, EXCEPT WITH RESPECT TO THOSE CHARACTERISTICS AUTHORIZED BY VARIANCE NUMBER 2017-V-4837 EFFECTIVE September 13, 2017.

This projector may become RG3 when an interchangeable lens with throw ratio greater than 3.5 is installed. Refer to the manual for the lens list and hazard distance before operation. Such combinations of projector and lens are intended for professional use only, and are not intended for consumer use.

Ce projecteur peut devenir un projecteur RG3 en cas d'installation d'un objectif interchangeable dont le rapport de projection est supérieur à 3.5. Veuillez vous reporter au manuel pour en savoir plus sur la liste des objectifs et la distance de sécurité avant toute utilisation. De telles combinaisons entre projecteur et objectif sont conçues pour des applications professionnelles uniquement et pas pour des applications grand public.

## 1. Safety

Label image	Label description	Label location
-------------	-------------------	----------------

本投影机安装透射比大于3.5的可换镜头后，可成为RG3，操作前，请参考手册中镜头清单和危险距离。本投影机与镜头组合仅供专业使用，非普通消费者使用。

For F80-Ultra, F80-4K9, F80-Q9 :



For North America: THIS PRODUCT IS IN CONFORMITY WITH PERFORMANCE STANDARDS FOR LASER PRODUCTS UNDER 21 CFR 1040, EXCEPT WITH RESPECT TO THOSE CHARACTERISTICS AUTHORIZED BY VARIANCE NUMBER 2017-V-4837 EFFECTIVE September 13, 2017.

This projector may become RG3 when an interchangeable lens with throw ratio greater than 2.8 is installed. Refer to the manual for the lens list and hazard distance before operation. Such combinations of projector and lens are intended for professional use only, and are not intended for consumer use.

Ce projecteur peut devenir un projecteur RG3 en cas d'installation d'un objectif interchangeable dont le rapport de projection est supérieur à 2.8. Veuillez vous reporter au manuel pour en savoir plus sur la liste des objectifs et la distance de sécurité avant toute utilisation. De telles combinaisons entre projecteur et objectif sont conçues pour des applications professionnelles uniquement et pas pour des applications grand public.

本投影机安装透射比大于2.8的可换镜头后，可成为RG3，操作前，请参考手册中镜头清单和危险距离。本投影机与镜头组合仅供专业使用，非普通消费者使用。

## 1.4 Risk Group 3 Safety

### 1.4.1 General considerations

#### Notice on optical radiation from F80 Projector when it becomes Risk Group 3.

- For RG3, no direct exposure to the beam shall be permitted. For RG3, operators shall control access to the beam within the hazard distance or install the product at a height that will prevent eye exposure within the hazard distance.
- This projector has one or several built-in Class 4 laser clusters. Disassembly or modification is very dangerous and should never be attempted.
- Any operation or adjustment not specifically instructed by the user's guide creates the risk of hazardous laser radiation exposure.
- Do not open or disassemble the projector as this may cause damage by the exposure of laser radiation.

FOR PROFESSIONAL USE ONLY means installation can only be carried out by Barco AUTHORIZED PERSONNEL familiar with potential hazards associated with high intensity light beams.



**WARNING: No direct exposure to the beam within the hazard distance shall be permitted, RG3 (Risk Group 3) IEC 62471-5:2015**



**CAUTION: Use of controls or adjustments or performance of procedures other than those specified herein may result in hazardous radiation exposure.**

### 1.4.2 High Brightness precautions: Hazard Distance (HD)



**HD**

Hazard Distance (HD) is the distance measured from the projection lens at which the intensity or the energy per surface unit becomes lower than the applicable exposure limit on the cornea or on the skin. The light beam is considered (to be) unsafe for exposure if the distance from a person to the light source is less than the HD.



## Restriction Zone (RZ) based on the HD

The HD depends on the amount of lumens produced by the projector and the type of lens installed. See next chapter "HD in function of the lens Throw Ratio (TR)", page 11.

To protect untrained end users (as cinema visitors) the installation shall comply with the following installation requirements: Operators shall control access to the beam within the hazard distance or install the product at the height that will prevent spectators' eyes from being in the hazard distance. Radiation levels in excess of the limits will not be permitted at any point less than 2.0 meter (SH) above any surface upon which persons other than operators, performers, or employees are permitted to stand or less than 1.0 meter (SH) lateral separation from any place where such persons are permitted to be. In non-cinema environments where unrestrained behavior is reasonably foreseeable, the minimum separation height should be greater than or equal to 3.0 meter to prevent potential exposure, for example by an individual sitting on another individual's shoulders, within the HD.

These values are minimum values and are based on the guidance provided in IEC 62471-5:2015 section 6.6.5.

The end user must understand the risk and apply protective measures based upon the hazard distance as indicated on the label and in the user information. Installation method, barriers, detection system or other applicable control measure shall prevent hazardous eye access to the radiation within the hazard distance.

For example, projectors that have a HD greater than 1 m and emit light into an uncontrolled area where persons may be present should be positioned in accordance with "the fixed projector installation" parameters, resulting in a HD that does not extend into the audience area unless the beam is at least 2.0 meter above the floor level. In non-cinema environments where unrestrained behavior is reasonably foreseeable, the minimum separation height should be greater than or equal to 3.0 meter to prevent potential exposure, for example by an individual sitting on another individual's shoulders, within the HD. For example, a sufficiently large separation height may be achieved by mounting the image projector on the ceiling or through the use of physical barriers.

For applications installed in the USA market the above limits for cinema like environments do not apply. The relevant minimum separation height is 2.5m (8.2 ft) by the FDA CDRH. Non cinema like environments require 2.5 meter (8.2 ft) separation height and 1.0 meter (3.3 ft) separation width for areas where restrained behavior is to be expected. All other areas require 3.0 (9.9 ft) separation height.

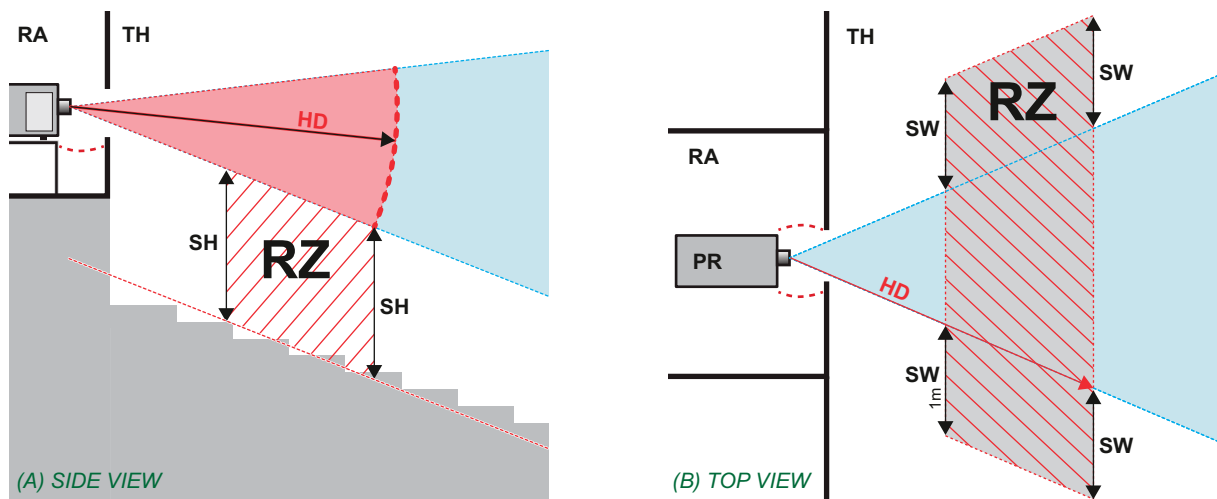

Image 1-1

- A Side view.
- B Top view.
- RA Restricted Access location (boot area of projector).
- PR Projector.
- TH Theater.
- RZ Restriction Zone in the theater.
- SH Separation Height.
- SW Separation Width.

Based on national requirements, no person is allowed to enter the projected beam within the zone between the projection lens and the related hazard distance (HD). This shall be physically impossible by creating sufficient separation height or by placing barriers. The minimum separation height takes into account the surface upon which persons other than operator, performers or employees are permitted to stand.

On image 1-2 a typical setup is displayed. It must be verified if these minimum requirements are met. If required a restricted zone (RZ) in the theater must be established. This can be done by using physical barrier, like a red rope as illustrated in image 1-2.

The restricted area sticker can be replaced by a sticker with only the symbol.

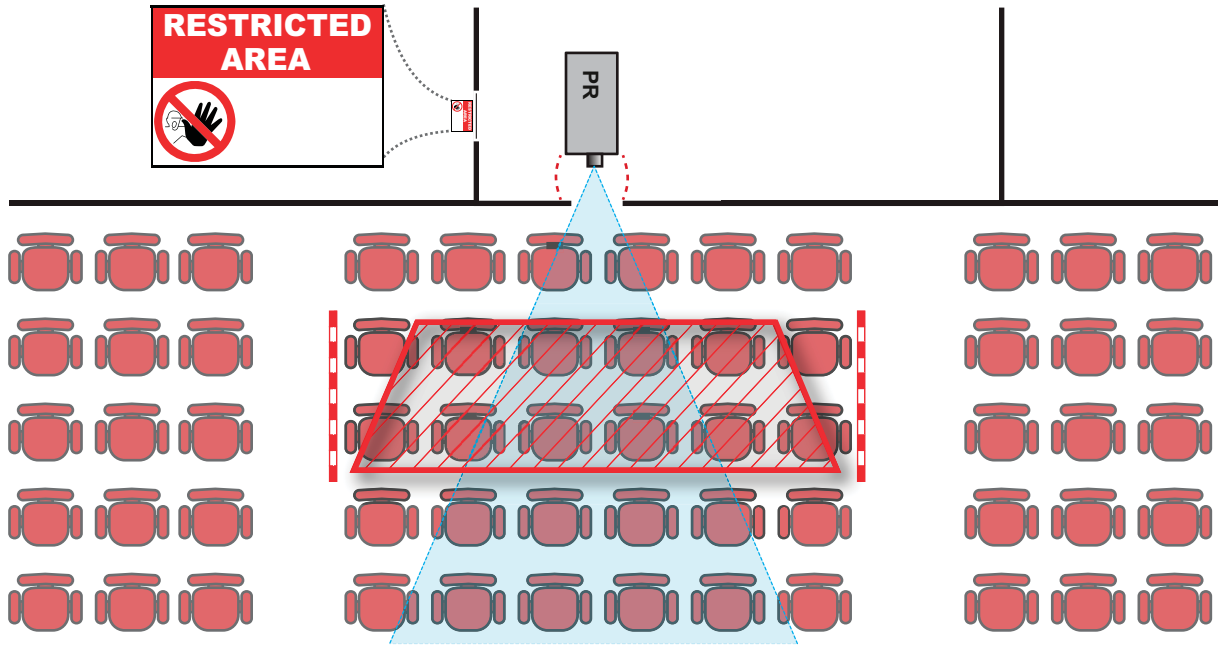

Image 1-2

### 1.4.3 HD for fully enclosed projection systems



#### HD

Hazard Distance (HD) is the distance measured from the projection lens at which the intensity or the energy per surface unit becomes lower than the applicable exposure limit on the cornea or on the skin. The light beam is considered (to be) unsafe for exposure if the distance from a person to the light source is less than the HD.

#### Restriction Zone (RZ) based on the HD

The projector is also suitable for rear projection applications; projecting a beam onto a diffuse coated projection screen. As displayed in image 1-3 two areas should be considered: the restricted enclosed projection area (RA) and the observation area (TH).

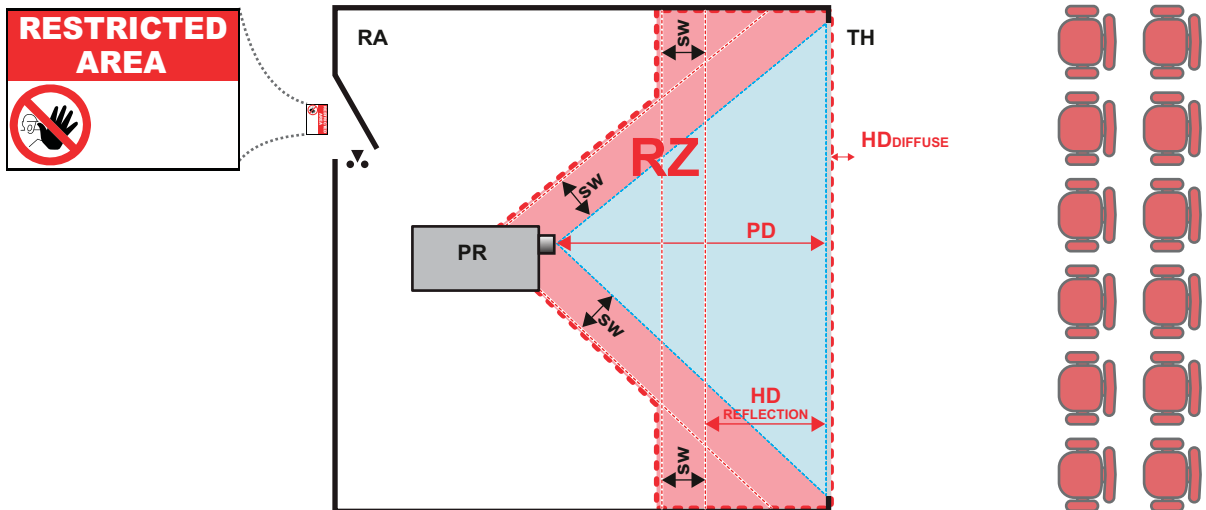

Image 1-3  
 RA Restricted Access location (enclosed projection area).  
 PR Projector.  
 TH Theater (observation area).  
 RZ Restriction Zone.  
 PD Projection Distance.  
 SW Separation Width. Must be minimum 1 meter.

For this type of setup 3 different HD shall be considered:

- HD as discussed in "High Brightness precautions: Hazard Distance (HD)", page 8, relevant for intrabeam exposure.
- $HD_{\text{reflection}}$ : the distance that has to be kept restrictive related to the reflected light from the rear projection screen.
- $HD_{\text{diffuse}}$ : the relevant distance to be considered while observing the diffuse surface of the rear projection screen.

As described in "High Brightness precautions: Hazard Distance (HD)", page 8, it is mandatory to create a restricted zone within the beam areas closer than any NOHD. In the enclosed projection area the combination of two restricted zones are relevant: The restricted zone of the projected beam toward the screen; taking into account 1 meter Separation Width (SW) from the beam onward. Combined with the restricted zone related to the rear reflection from the screen ( $HD_{\text{reflection}}$ ); also taking into account a 1 meter lateral separation.

The  $HD_{\text{reflection}}$  distance equals 25% of the difference between the determined HD distance and the projection distance to the rear projection screen. To determine the HD distance for the used lens and projector model see graphs in chapter "HD in function of the lens Throw Ratio (TR)", page 11.

$$HD_{\text{reflection}} = 25\% (HD - PD)$$

The light emitted from the screen within the observation shall never exceed the RG2 exposure limit, determined at 10 cm. The  $HD_{\text{diffuse}}$  can be neglected if the measured light at the screen surface is below 5000 cd/m<sup>2</sup> or 15000 LUX.

### 1.4.4 HD in function of the lens Throw Ratio (TR)



#### TR (Throw Ratio)

The ratio of the distance to the screen (throw) to the screen width.

#### HD versus Throw Ratio

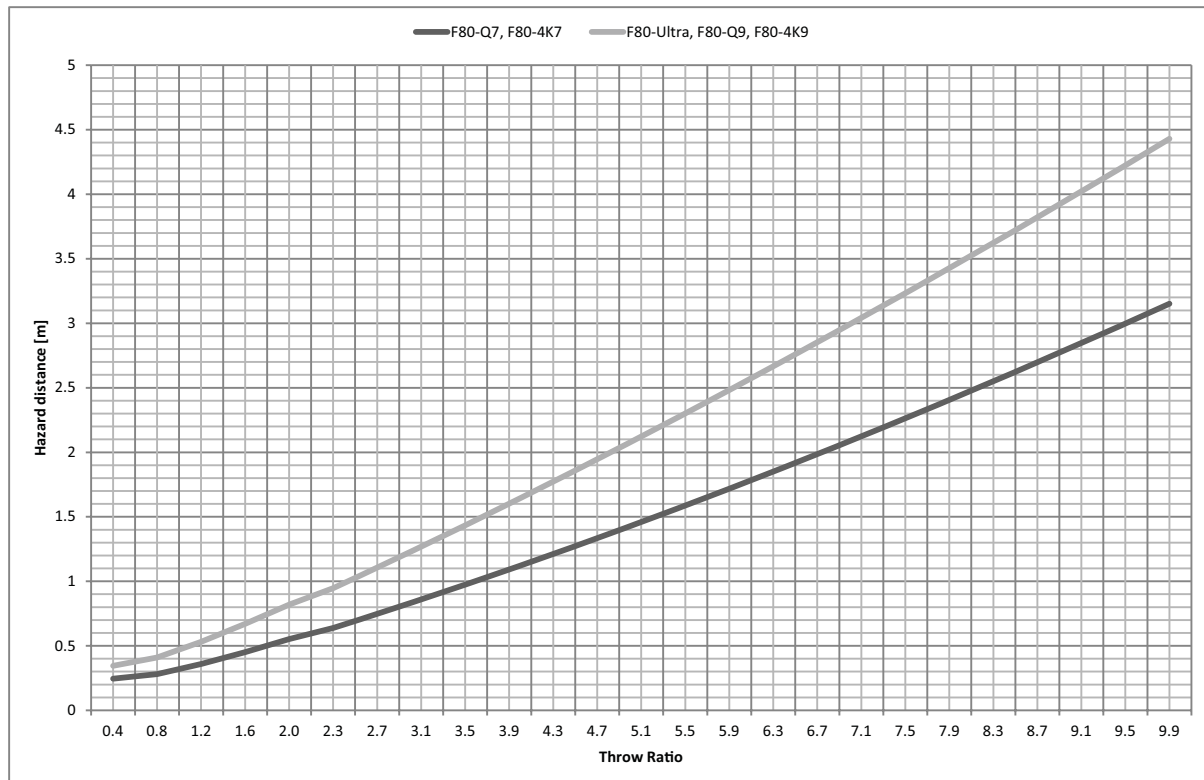

Image 1-4

Graph shows Hazard Distance in meters versus Throw ratio of the lens



## 2. REMOTE CONTROL UNIT

### 2.1 Remote control, Battery installation

#### Where to find the batteries for the remote control ?

The batteries are not placed in the remote control unit to avoid control operation in its package, resulting in a shorter battery life time. At delivery the batteries can be found in a separated bag attached to the remote control unit. Before using your remote control, install the batteries first.

#### How to install

1. Push the battery cover tab with the fingernail a little backwards (1) and pull, at the same time, the cover upwards (2).

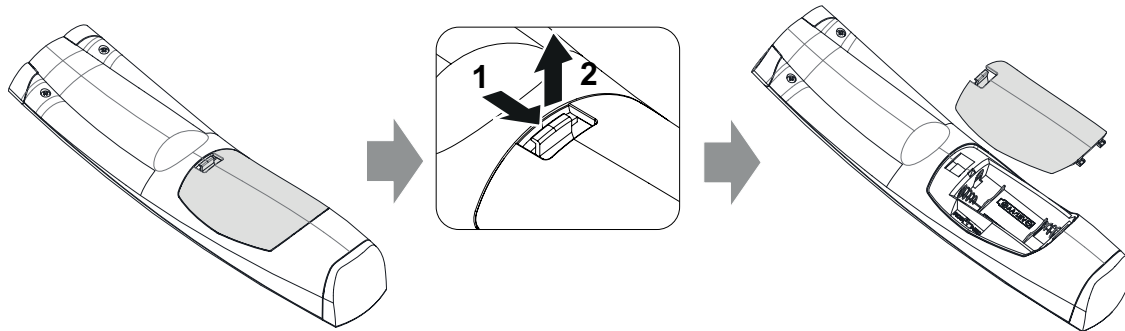

Image 2-1

2. Insert the two AA size batteries, making sure the polarities match the + and - marks inside the battery compartment.

**Tip:** Use alkaline batteries for optimum range and life time.

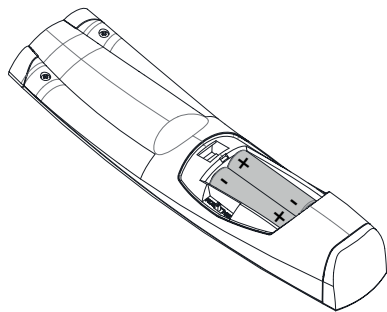

Image 2-2

3. Insert (1) both lower tabs of the battery cover in the gaps at the bottom of the remote control, and press (2) the cover until it clicks in place.

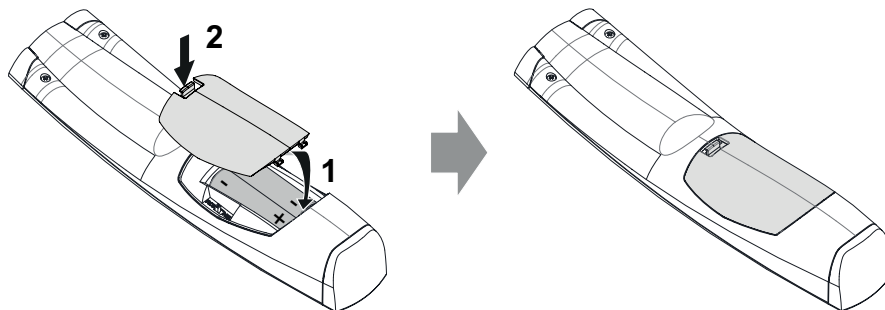

Image 2-3



When replacing batteries, the broadcast address of the RCU will be reset to its default value '0'.



**CAUTION:** Replace with the correct battery type. Use two AA size batteries. There is a risk of explosion if the battery is replaced with an incorrect type.

---



**CAUTION:** Replace the battery as explained above. There is a risk of explosion if the battery is incorrectly installed.

---

## 2.2 Using the XLR connector of the RCU

---



Connecting a cable with the XLR connector will reset the broadcast address of the RCU to its default value '0'.

---

### How to use the XLR connector

1. Remove the XLR cover by pulling it backwards.

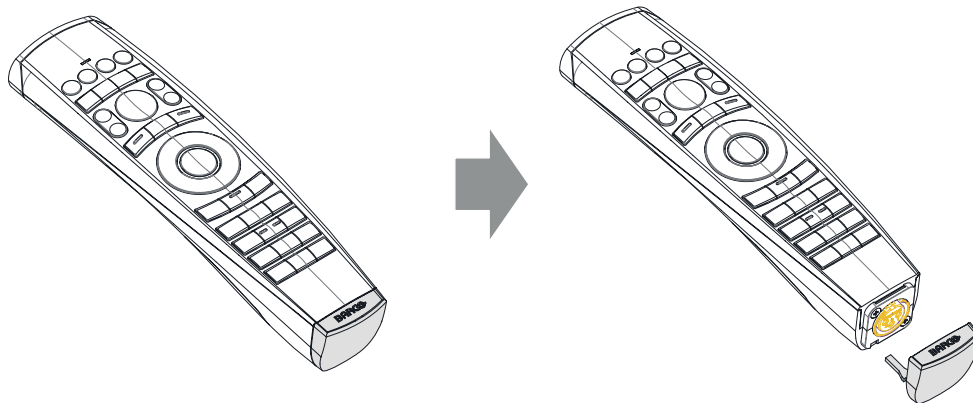

Image 2-4

2. Connect a cable with XLR plug into the XLR connector of the RCU.
3. Connect the other end of the cable with the XLR input of the projector.

## 2.3 Remote control, on/off button

---

### Purpose of the remote control on/off button

The Pulse remote control unit has at the front side an on/off switch (reference 1 image 2-5). Switching off the remote control prevents that unwanted commands are sent due to an accidental key press. Furthermore, switching the RCU off will extend the battery life time of the remote control.

To activate the remote control press the on/off button.

To deactivate the remote control press the on/off button again.

Default when (re)placing batteries, is "ON".

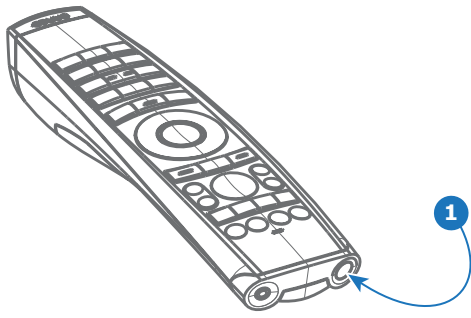

Image 2-5





# 3. INPUT & COMMUNICATION

## Overview

- Introduction
- Connection Panel
- Making connections
- Connector specifications
- Control interfaces
- LED and Button indication chart

## 3.1 Introduction

### General

The Input & Communication features of the projector consists of a local keypad and a communication panel situated at the left side, and a connection panel (sources and control connections) located at the back side.

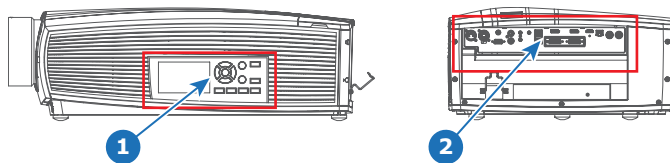

Image 3-1  
 1 local keypad and a communication panel  
 2 connection panel

## 3.2 Connection Panel

### General

Projector sources and control connections are located at the back of the projector.

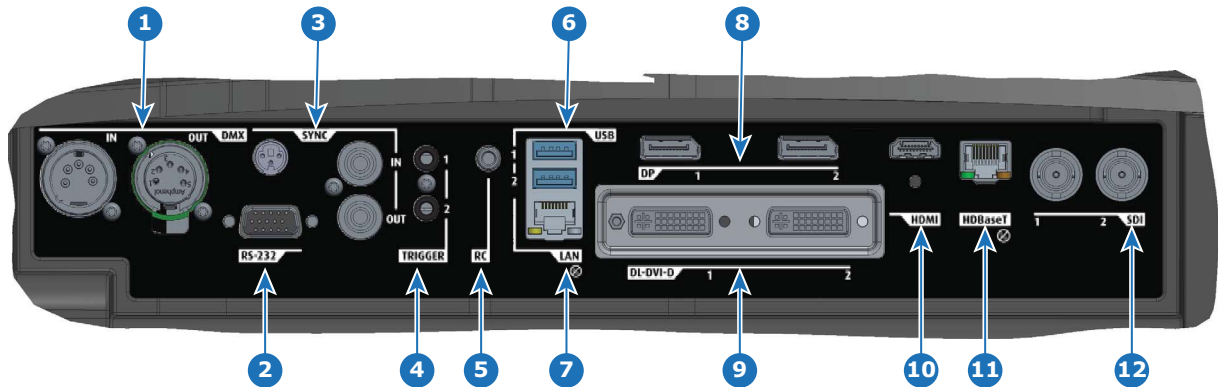

Image 3-2

Nb	Name	Pcs	Description	Purpose
1	DMX IN/OUT	2	DMX 512 input / DMX 512 output	For Projector Control
2	RS-232	1	9-pin DB9 connector	For Projector Control. Allows for wired remote control and monitoring of many projector functions used in installation environments
3	Sync	3	BNC Sync Port IN/OUT; Bidirectional mini-DIN (1x 3D sync Out, and 2x Sync In/Out)	For Projector Control. This is mainly used in multiple projector installations with requirement of synchronization between the units
4	Trigger	2	12VDC - 0,5A (6W)	For Controlling Peripherals, like motorized screens, curtains etc. Give 12V output when projector are switched on <b>See also the note below.</b>

### 3. Input & Communication

Nb.	Name	Pcs	Description	Purpose
5	RC	1	Mini jack 3,5mm connector for wired remote	For Projector Control
6	USB	2	USB 2.0 type A, 4 pin( 2x Rear and 1x Front)	For Software upgrade
7	LAN	1	Standard RJ45 connector	For Projector Control
8	DP	2	Standard display port	For Projector Input
9	DL-DVI-D	2	Dual DVI-I 1.0 (DVI_D Functionality).	For Projector Input. These connectors can also be used to form one uniform image by feeding half of the image into each connector. HDCP compliant for sources up 165 Mhz
10	HDMI	1	Standard HDMI 2.0	For Projector Input
11	HDBaseT	1	Standard RJ45 8P8C Connector	For Projector Control
12	SDI	2	SDI1 is Input, SDI 2 is pass through. (out)	For Projector Input



**Regarding the Trigger Output:** If these outputs are loaded too heavy, there is a risk that the projector will go in reset mode, and restart. This causes no damage to the projector, but is an undesirable response. This will also happen if the startup current for the external equipment is too high, even though the nominal power consumption is less than 0,5A.

### 3.3 Making connections



The source switching time varies from 0.5 to 5 seconds.

#### Source signal connectivity

The connector panel at the back of the projector is used for all source connections.

Source signal connectivity on the projector is:

- 2x Dual Link DVI-I (DVI-D functionality)
- 2x DisplayPort 1.2
- 1x HDMI 2.0
- 1x HDBaseT
- 1x 3G SDI

### 3.4 Connector specifications

#### Overview

- DVI-I
- Display Port 1.2
- HDMI 2.0
- 3G-SDI
- HDBase T

#### 3.4.1 DVI-I

##### Specifications

Parameter	Value
Connector	DVI-I female digital RGB
Signal characteristics	DVI 1.0, Digital, TMDS
Max. cable length	25 m (24 AWG)

Parameter	Value
Max. pixel rate	330 MHz (dual link), 165 Mhz (single link)
Scan format	Progressive
Max. input data resolution	1920x1200 60Hz (Single link), 2560x1600 60Hz (Dual Link), 1920x2400 @60Hz
Bit depth	8 bit
EDID	Supported
HDCP	Supported

### 3.4.2 Display Port 1.2

#### Specifications

Parameter	Value
Connector	Standard Display port
Signal characteristics	DP 1.2
Functionality	Mandatory
Max. cable length	15 m (24 AWG) - RBR; 2 m (24 AWG) – HBR1, HBR2
Supported Link Rate	RBR, HBR1, HBR2
Scan format	Progressive
Max. input data resolution	4096x2160 @60Hz (4K ) Max
Bit depth	8, 10, 12 bit
EDID	Supported
HDCP	Supported

### 3.4.3 HDMI 2.0

#### Specifications



Regarding HDMI 2.0: The decryption protocol HDCP 2.2 are enabled and valid in this unit.

Parameter	Value
Connector	Standard HDMI
Signal characteristics	Digital, TMDS
Max. cable length	15 m (24 AWG)
Max. pixel rate	594MHz
Max. input data resolution	3840x2160 @60Hz
Bit depth	8, 10, 12 bits
EDID	Supported
HDCP	Supported
Ethernet	No
Audio return	No

### 3.4.4 3G-SDI

#### Specifications

Parameter	Value
Standard	SMPTE 424M-2006 10bit level A

### 3. Input & Communication

Parameter	Value
Connectors	1x) BNC 75 ohm type IEC 60169-8, Amendment 2 1997, A
Bandwidth	>3 GHz
Return loss	>10dB at 3GHz
Impedance	75 ohm resistive

#### 3.4.5 HDBase T

##### Specifications

Parameter	Value
Reference specification	HDBaseT 1.0 Specification, June 2010
Connector	Standard RJ-45, 8P8C
Signal characteristics	HDBaseT
Max. cable length (1080p/48b/60Hz)	100 m (Cat5e/6), Pixel Clock <=225MHz, Video Datarate <=5.3Gbps 70 m (Cat5e/6), Pixel Clock >225MHz, Video Datarate >5.3Gbps 100 m (Cat6a/7), Pixel Clock >225MHz, Video Datarate >5.3Gbps
Max TMDS Clock Frequency	270 MHz
Max video resolution supported	1920x1200 @60Hz (WUXGA 60Hz)
HDCP Pass-Through	Yes, from Source to Projector
IR Extension	Not Supported
RS-232 Extension	Not Supported
10/100Mbps Ethernet Pass-Through	Not Supported
Fallback to 100BaseTx, IEEE 802.3u	Not Supported
USB Over Centre Tap	Not Supported
Power Over Ethernet	Not Supported
Audio	Not Supported
LEDs - HD Base Status	Operation: Green, Left Link/Mode: Yellow, Right

### 3.5 Control interfaces

#### About

The following control interfaces are available on the projector:

- 1x RS-232 (for projector control)
- 1x LAN/Ethernet (for projector control)
- 3x USB-A ports

#### Overview

- RS-232
- LAN/Ethernet
- USB-A port

#### 3.5.1 RS-232

##### Specifications

Parameter	Value
RS-232 connector	1 female DB9 connector (RS232-in) for projector control and debug

### 3.5.2 LAN/Ethernet

#### Specifications

Parameter	Value
Ethernet connector	1 RJ45 Connector for projector control (not content)
Protocols	DHCP, TCP/IP, UDP/P
Speed	10/100 Mbit/1000Mbit

### 3.5.3 USB-A port

#### Specifications

Parameter	Value
USB connector	Type A
Function	Firmware upgrade using USB sticks
Power	Power 5V, max 1,5A (out)
Standard	USB 2.0

## 3.6 LED and Button indication chart

#### Button Backlight Status

Button	Color status	Description
Standby button 	Blinking WHITE (slow)	Projector starts up (booting)
	Blinking WHITE (fast)	Firmware upgrade
	Solid WHITE	Projector is in Standby mode
	Blinking BLUE	Projector goes to ON mode
	Solid BLUE	Projector is ON
	Blinking RED	Error condition
Shutter button 	Off (no color)	Projector is OFF, starts up, or is in Standby mode.
	Solid WHITE	Projector is ON, shutter is open
	Solid RED	Projector is ON, shutter is closed

#### LED Status

The LED status is located on the top side of the projector, near the IR receiver.

During normal operation the LED is unlit. In the event of a critical error or high temperature, the LED will display red.

By critical error, the projector cannot be restarted until the projector is disconnected from the power supply and then reconnected again. If the reason for the error persist, the projector will again go to critical error status.

By high temperature, the projector will restart when it has cooled down, and temperatures are back within the normal operating limitations.



## 4. GETTING STARTED

### About this chapter

This chapter describes how to power up, control and set up your projector setup when the physical installation process is complete.

### How controlling the projector ?

The projector can be controlled by the local keypad, by the remote control unit or by browser application.

### Location of the local keypad ?

The local keypad is located on the right side of the projector.

### Remote control functions.

This remote control includes a battery powered infrared (IR) transmitter that allows the user to control the projector remotely. This remote control is used for source selection, control, adaptation and set up.

Other functions of the remote control are :

- switching between stand by and operational mode.
- switching to "pause" (blanked picture, full power for immediate restarting)
- direct access to all connected sources.

### Overview

- Functionality overview
- Power modes
- Power mode transitions
- Status overview
- Power off projector
- Operation in 24/7 Mode
- Using the RCU
- Projector Address
- Quick setup via Direct access

## 4.1 Functionality overview

### Local Keypad overview

- 1 Menu Selection.
- 2 Menu Activation, OK button
- 3 OSD On/Off.
- 4 Menu Back.
- 5 Power On/Off.
- 6 Touch Panel On/Off.
- 7 Input Selection.
- 8 Shutter Open/Close.
- 9 Test Patterns.
- 10 Lens Menu.
- 11 Touch Panel.

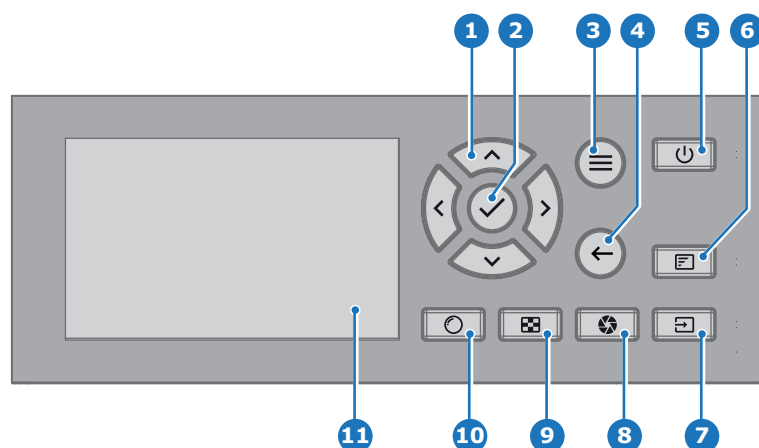

The Keypad gives direct access to several functions, in addition to access to the menu system.

The keypad has a back light that can be switched on and off manually. The light turns off automatically after a preselected time.

## 4. Getting Started

The keys are equipped with white and blue backlit LEDs. Power button is equipped with white, blue and red backlit. The LEDs are controlled according to the features available.

### Remote Control Unit buttons

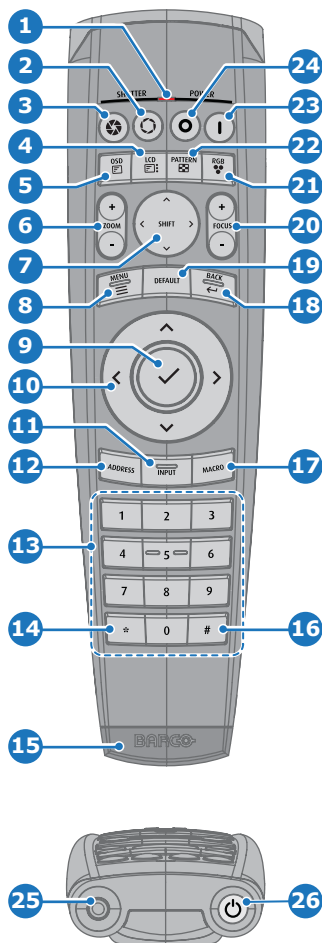

- |                              |   |
|------------------------------|---|
| 1 Button pressed indicator.  | 14 Backspace (while entering values)    |
| 2 Shutter Open.              | 15 XLR connector.                       |
| 3 Shutter Close.             | 16 Decimal mark (while entering values) |
| 4 Touch Panel On/Off.        | 17 Macro button.                        |
| 5 OSD On/Off.                | 18 Menu Back.                           |
| 6 Lens Zoom.                 | 19 Default button.                      |
| 7 Lens Shift.                | 20 Lens Focus.                          |
| 8 Menu Activation.           | 21 Color On/Off.                        |
| 9 Menu Selection, OK button. | 22 Test Patterns.                       |
| 10 Menu Navigation.          | 23 Power On.                            |
| 11 Input Selection.          | 24 Power Off.                           |
| 12 Address button.           | 25 Stereo Jack.                         |
| 13 Numeric buttons.          | 26 RCU On/Off.                          |

The projector remote control is a full feature wireless remote control, powered by two (2) standard AA batteries. The battery compartment is on the back side of the remote control.

The remote control is backlit for use in dark environments. It also has an XLR connector for wired connection to the projector. When the wire is connected, the IR beam is switched off.

### LCD panel

The LCD panel has two main functions:

1. Showing the menus and adjustment information. and also a mirror of the OSD, (On Screen Display) described in *User Interface* when this is enabled.
2. Information regarding the status of the projector showing this data:
  - Projector status
  - Network address
  - Active source
  - Current firmware version
  - Operation Data
  - Active functions (Enabled Functions).

Toggle between the two indications by using the **Menu** button on the keypad, or on the remote control

The LCD Display will fade out 30 seconds after the last key operation.

## 4.2 Power modes

### General

The table below details the F80 power modes.



Mode	Description
ON (normal)	Projector is booted up and the light source is on
READY	Projector is booted up but the light source is off
ECO (Standby)	Light source is switched off and projector electronics are powered down



Energy consumption is significantly lower in ECO (Standby) mode: only <0.5W if network is not plugged in and 2W with network (WakeOnLan).



In ECO (Standby) mode, remote power up (Wake-on-LAN) and local power up (button) are supported.

### 4.3 Power mode transitions

#### 4.3.1 General

##### Transition Diagram

This diagram shows all modes available on the projector (unplug, ON, READY, ECO), and the actions necessary to change mode.

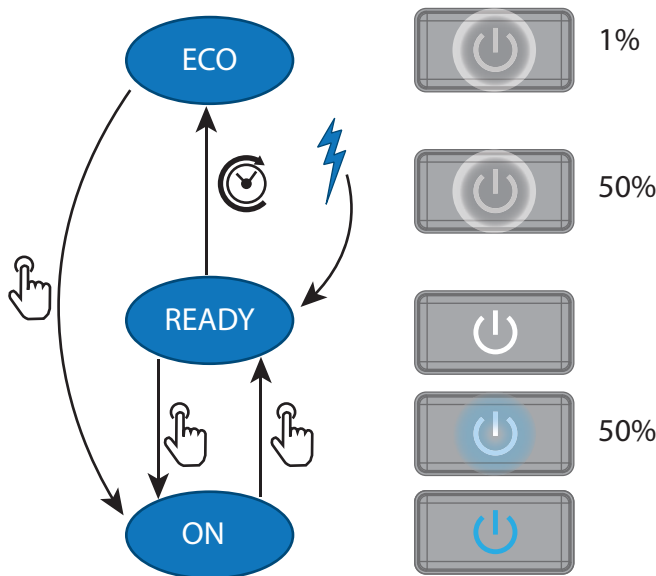

Image 4-1

- Projector mains powered
- Auto transition after x minutes if ECO mode enables
- Press power On/Off button, remote On/Off button

#### 4.3.2 Power on projector



If not already connected, connect the female side of the power cord with the power input socket of the projector. For more details see section dedicated to the power cord installation.



The background image of the startup screen and info screens can be changed with Projector Toolset with an installed F80 plug-in.

---

### Description

Plug the 3-prong plug of power cord into a grounded AC outlet. The projector will go to **READY** mode. During this stage the system boots and performs the internal check of the boards. The *Power On/Off button* will BLINKING WHITE until **READY** mode is achieved. Once in **READY** mode, the *Power On/Off button* will be lit WHITE.

### 4.3.3 Going from READY to ON

#### Description

Press the *Power On/Off button* on the projector, or the *Power On button* on the remote control. The projector will power **ON**. The *Power On/Off button* will BLINK BLUE during the transition from **READY** to **ON**. Once the projector is on, the *Power On/Off button* will be lit BLUE.

### 4.3.4 Going from ON to READY

#### Description

Press the *Power on/off button* on the projector, or the *Power On button* on the remote control. The projector will power down through a cool down phase. The *Power on/off button* will BLINK WHITE during the transition from **ON** to **READY**. Once the projector is in **READY**, the *Power on/off button* will be lit WHITE.

### 4.3.5 Going from READY to ECO standby

#### Description

If ECO Standby mode is enabled in the service menu (refer to the section "GUI - system settings/Standby ECO", in User Guide) the projector will automatically go to **ECO** standby mode after a time-out (default 15 minutes). All electronics (including fans, pumps,...) go down except for a very small wake up controller. The *Power on/off button* will FLASH WHITE every second.

### 4.3.6 Going from ECO to ON

#### Description

Press the *Power on/off button* on the projector, or the *Power On button* on the remote control or do a wake on LAN. The projector goes from **ECO** directly to **ON**. The projector will go through the same booting phase as on power plugging, then do the transition from **READY** to **ON**. Of course startup-time will be longer then from **READY** to **ON**.

## 4.4 Status overview

---

### Description

Once the projector is started, press **Status** to get an overview of parameters such as :

- Chosen source
- Current resolution and refresh rate
- Device serial number and article number
- Current firmware version and model name
- Current illumination (in percentage)
- Lamp runtime in hours
- Chosen communication method and IP address (if connected)
- Warp status
- Environmental temperature

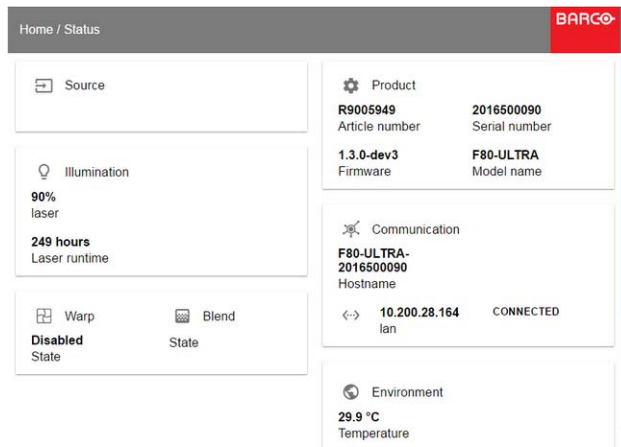

Image 4-2

## 4.5 Power off projector

### How to Switch off the projector

1. Use the *standby button*, or the *Power On* button on the remote control, to switch off the projector.  
The projector will switch to **READY** mode first in order to run through a cool down phase (see "Power mode transitions", page 25).
2. If **ECO** Standby mode is enabled in the service menu (refer to the section "GUI - system settings/Standby ECO", in User Guide) the projector will automatically go to **ECO** standby mode after a time-out (default 15 minutes).



Some actions like apply a grey test pattern are done during the two minutes of the cool down phase in order to minimize the potential effect of burn-in and increase the projector lifetime.



**CAUTION:** Never switch off the projector by means of unplugging mains cord or by cut down of mains power.



Barco advises to keep the projector always powered and use the **ECO** mode for low power consumption.

### How to unplug the projector

1. Follow the procedure above to Switch Off the projector.
2. Wait at least 2 minutes prior to unplug the projector by removing the power cord from the AC outlet.



**CAUTION:** It is very important to wait few minutes before unplug the power cord. If the cool down phase is not adhered, projector lifetime could be degraded.

## 4.6 Operation in 24/7 Mode

### General

When the projector is destined to be operated continuously 24 hours a day / 7 days a week, some rules must be followed to minimize the potential effect of burn-in and increase the projector lifetime.

## 4. Getting Started

### Important rules

If using the projector 24 h/day, please adhere to the following rules:

- Make sure to temporarily switch off the projector during 2 minutes at least once per 12 hours. The power down action will automatically and invisibly trigger a grey test pattern running within the projector. Alternatively, if you do not want to shut down the projector, you can choose to select the grey test pattern yourself within the normal "on" mode.
- Apply moving video content as much as possible, with on average a level of 50% white (long-term use of extreme black or white content could potentially cause burn in).

## 4.7 Using the RCU

### Pointing to the reflective screen

1. Point the front of the RCU to the reflective screen surface.

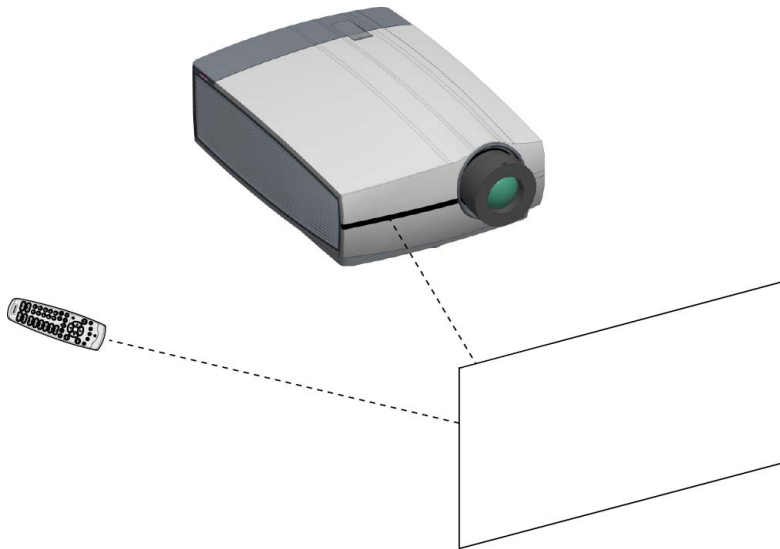

Image 4-3  
IR control via reflective screen

### Hardwired to the mini jack input

1. Plug one end of the remote cable in the connector on the front side (3,5mm mini jack) of the RCU.
2. Plug the other end in the connector on the communication interface of the projector, labelled **Remote CTRL**(reference 1, image 4-4).

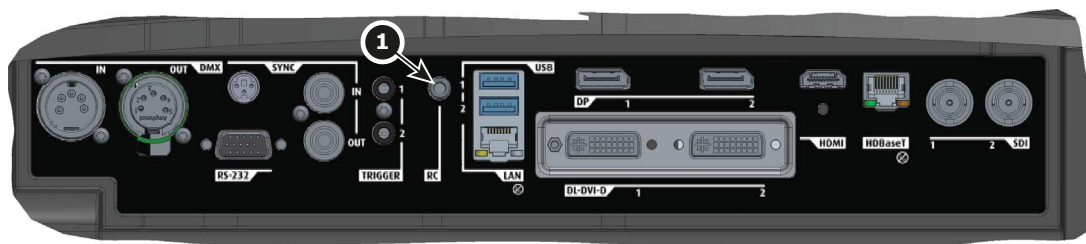

Image 4-4

**Note:** *Plugging the remote control will switch the broadcast address of the remote control to the default value '0'. This is the only broadcast address that will work when hardwired. If you want to change the broadcast address after disconnecting the remote control, see "Projector Address", page 29.*

### Pointing directly to the IR sensor

When using the wireless remote control, make sure you are within the effective operating distance (30m, 100ft in a straight line). The remote control unit will not function properly if strong light strikes the sensor window or if there are obstacles between the remote control unit and the projector IR sensor.

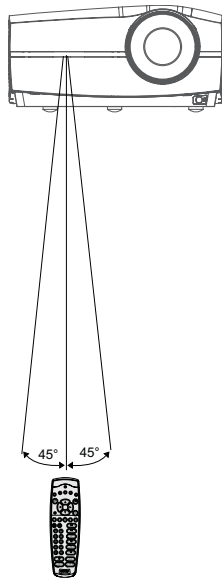

Image 4-5  
RCU to one of the IR sensors

## 4.8 Projector Address



### Projector address

Address installed in the projector to be individually controlled.



### Broadcast address

Projector will always execute the command coming from a RCU programmed with that broadcast address.

### 4.8.1 Controlling the projector

#### Why a projector address?

As more than one projector can be installed in a room, each projector should be separately addressable with an RCU or computer. Therefore each projector has its own address.

#### Set up an individual Projector Address

The set up of a projector address can be done via the software.

#### Projector controlling

Every projector requires an individual address between 0 and 255.

When the address is set, the projector can be controlled now:

- with the RCU: only for addresses between 0 and 31.
- with a computer: for any address between 0 and 255.

#### Broadcast Address

Every projector has a broadcast (common) address '0' or '1'. The default address is '0'.

The choice between '0' and '1' can be selected in the GUI: "System Settings" → "Communication" → "IR Control".



**Placing new batteries in the remote control or plugging the remote to a projector via a cable will automatically reset the address back to its default value '0'.**

## 4.8.2 Displaying and Programming addresses into the RCU

### Displaying the Projector Address on the Screen.

1. Press the **Address** button to see the projector address (proximately 2 seconds).  
The projector's address is displayed on the LCD status screen.

### How to Program an Address into the RCU?

1. Press the **Address** button until the *Button pressed indicator* lights up continuously (proximately 5 seconds).
2. Enter the address with the digit buttons within the time the indicator lights up (also proximately 5 seconds).

**Note:** That address can be any value between 0 and 31.

**Tip:** A few examples:

To enter address 3, press "3" digit button on the RCU to set the RCU's address to 3 and wait until the button pressed indicator is out. Alternatively, you can also press "0" and "3". This way, the button pressed indicator goes out immediately.

To enter address 31, then press "3" and "1" on the digit button on the RCU and the button pressed indicator goes out immediately.

## 4.9 Quick setup via Direct access

### Quick source selection

1. Press the **Input** button on the remote control or local keypad.

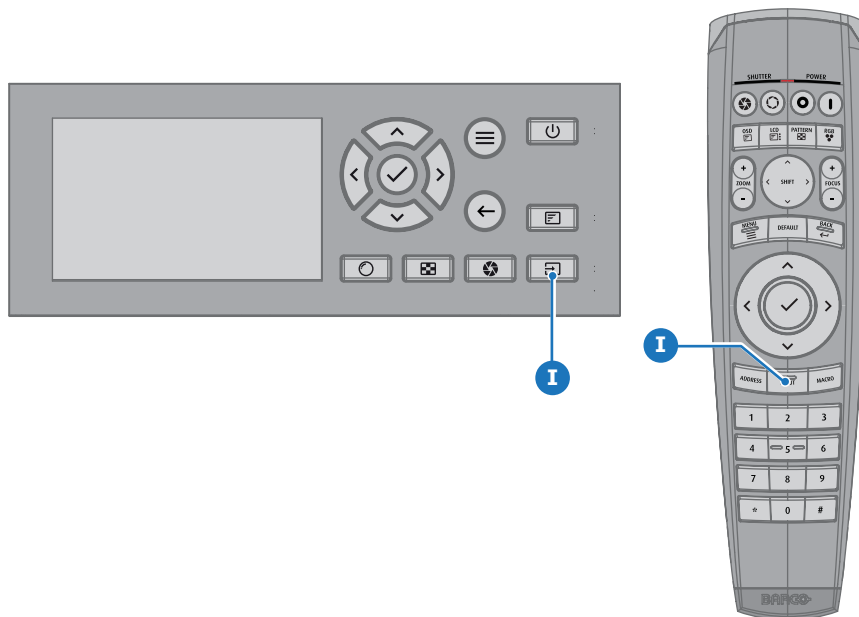

Image 4-6

The source selection menu opens.



Image 4-7  
Input selection

2. Use the arrow keys to select the desired source.

### Quick test pattern selection

1. Press the Test pattern button on the remote control or local keypad.

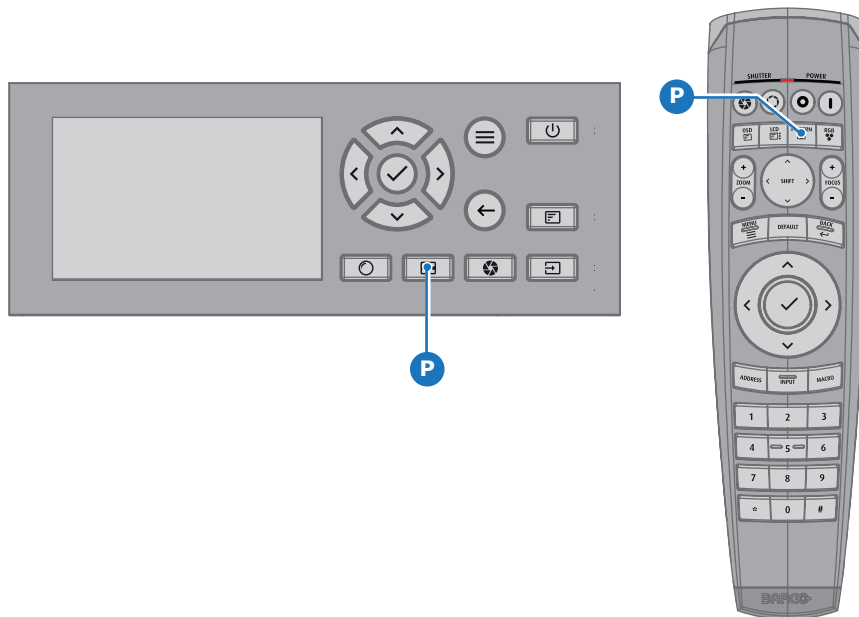

Image 4-8

A first test pattern will be displayed.

2. Press as many times on that button until the desired pattern is displayed





## 5. GRAPHIC USER INTERFACE (GUI)

### Overview

- Overview
- Navigation
- Test Patterns

### 5.1 Overview

#### GUI - Main Menu overview

The projector on screen display (OSD) is the primary user interface (UI). From here, you can review and adjust all projector and display settings.

The OSD interface uses tabs to display the main menu. Each main menu contains submenus.

The OSD can be disabled by pressing the OSD on/off button.

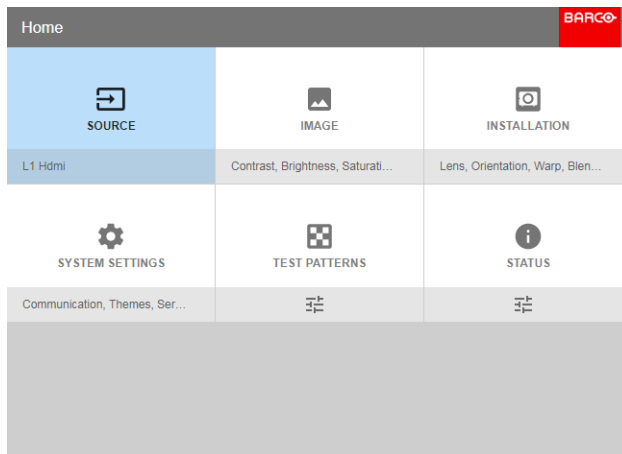

Image 5-1  
Home menu

The projector's software platform uses access levels what each user can do. A standard user has access to all projector functionality. A certified service technician has also access to the service menu. This menu is password protected.

### 5.2 Navigation

#### Navigation via the RCU or local keypad

Navigating the OSD can be done using the remote control or the local keypad.

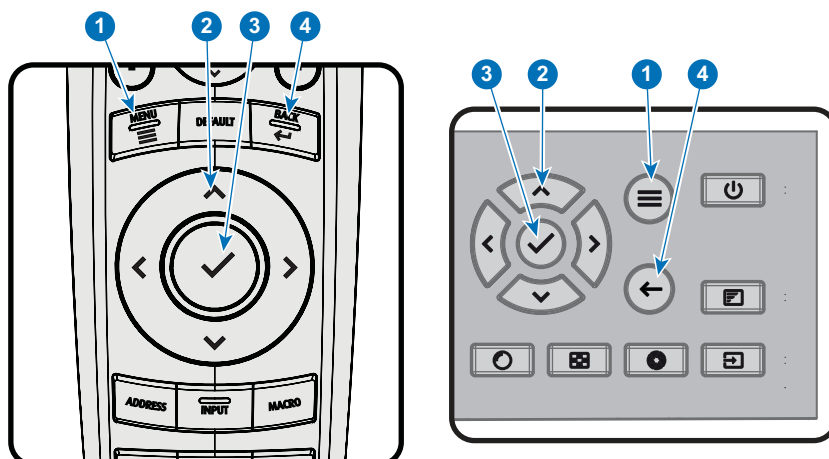

Image 5-2

## 5. Graphic User Interface (GUI)

---

To start up the menu structure, press **MENU** (1).

Use the arrow keys (**Menu Navigation** buttons) to navigate to the desired menu item (2). The background color changes to light blue.

Press the **Menu Selection** button (center key of the arrow keys), also called **OK** button, to activate that item and to jump one level deeper (3).

Use the numeral keys to enter values, or use the arrow keys to move the bar scale up or down.

Press the **Back** button to go up one level (4).

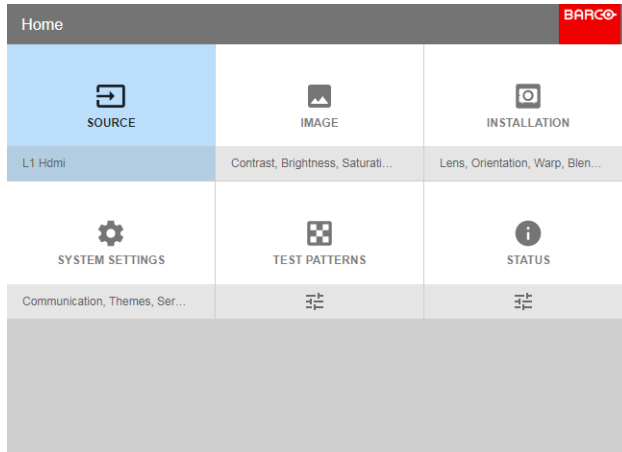

Image 5-3  
Home menu

Remark: a blue slider bar on the right side of the window means that there are more items to show than those currently displayed.

### Define values

Menu settings are displayed using check boxes, bar scale sliders, and drop-down lists.

To set a value:

- Press **OK** to select or deselect a checkbox (turn a function ON or OFF).
- Use the arrow keys to move the bar scale slider up or down on the value line. For a bar scale 0-9, each step will equal 10% of the total value.
- To enter the value as a direct number, press **OK**, input the digit(s), and then press **OK** again to execute and exit cursor mode e.g. OK 79 OK.  
Within an input field, use the \* button as backspace button to remove an entered digit. Use the # button to enter a dot (.).

Changes to values are implemented dynamically.

To enter values with the local keyboard, use the arrow keys to select the first digit, press **OK**. Select the second digit and press **OK**. Continue until all digits are entered. Close the action by selecting the **enter** (↵) button and press **OK**. Select the **backspace** button and press **OK** to remove the last entered digit.

### Menu memory

The OSD menu remembers the last selected sub-item as long as the projector is running. The menu memory is reset when restarting the projector from standby.

## 5.3 Test Patterns

---

### How to use test patterns

1. In the main menu, select *Test Patterns*.

Or,  
Push the *Test Patterns* button on the RC or on the local keypad.

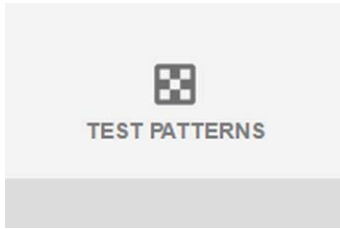

Image 5-4  
Main menu, Test Patterns

2. In the Test Patterns menu, select either *Patterns*, *Internal*, or *P7 Calibration* test patterns.

3. In the chosen submenu, select the desired test pattern from the list.

You can select one of the following *Patterns* test patterns:

- Refresh
- Native Black

You can select one of the following *Internal* test patterns:

- Aspect
- ANSI Lumen
- Checker Board
- Focus
- Cross hatch
- Mono scope
- FRHL
- Green
- Focus BW
- Color bars
- Blue
- Red
- White

You can select one of the following *P7 Calibration* test patterns:

- Native Red
- Native Green
- Native Blue
- Native White

4. To turn the test pattern off, return to the previous menu.



## 6. GUI – SOURCE

### About the Source menu

This menu is used to select, review and configure sources into the projector.

Overview of features

- Source Selection
- Connector Settings

### 6.1 Source Selection

#### How to select?

1. Press **Menu** to activate the menus and select *Source*.



Image 6-1  
Select Source

2. Press **OK**.

The *Select Source* menu is displayed with the actual available sources filled out.

3. Select the desired input.

### 6.2 Connector Settings

#### How to configure the connector

1. Press **Menu** to activate the menus and select *Source*.



Image 6-2  
Select Source

2. Press **OK**.

The *Select Source* menu is displayed with the actual available sources filled out.

3. Scroll down to the bottom of the list and select *Connector Settings*.

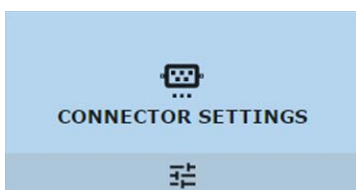

Image 6-3

The available sources are displayed.

4. Select the desired connector.

The **Connector Settings** menu for this connector will be displayed. All default values are **Auto**.

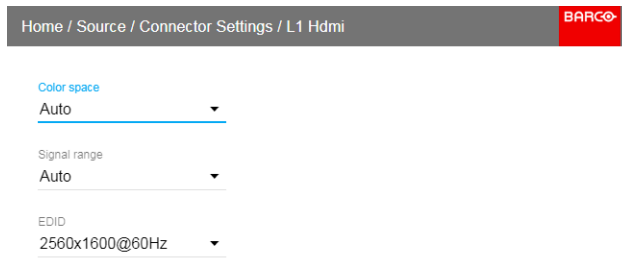

Image 6-4

5. To apply a limit on the used color space, select one of the other values in *Color space*.
6. To apply a limit on the used signal range, select one of the other ranges in *Signal Range*.

## 7. GUI – IMAGE

Overview of features

- Setting image levels manually
- P7 Realcolor
- HDR – Perceptual Quantizer (PQ)

### 7.1 Setting image levels manually

#### Purpose

**Contrast:** Change the contrast of the complete output signal (main and PiP window together) of the projected image.

**Brightness:** Change the brightness of the complete output signal (main and PiP window together) of the projected image.

**Saturation:** Change the saturation of the complete output signal (main and PiP window together) of the projected image.

#### How to set up Contrast

1. In the main menu, select *Image* → *Contrast*.



Image 7-1  
Image menu — Contrast

2. Use the ◀ or ▶ key to change the contrast enhancement until the desired value is reached (adjustable between 0 and 2).

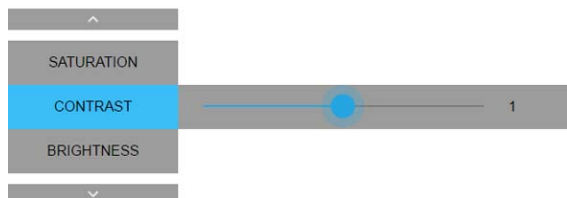

Image 7-2  
Contrast slider

3. Use the ▲ or ▼ key to select *Saturation* or *Brightness*.  
Or,  
go to *Home - Image* and select *Saturation* or *Brightness*.

#### How to set up Brightness Level

1. In the main menu, select *Image* → *Brightness*.

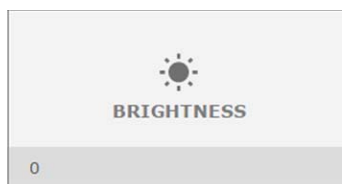

Image 7-3  
Image menu — Brightness

2. Use the ◀ or ▶ key to change the brightness until the desired value is reached (adjustable between -1 and 1).

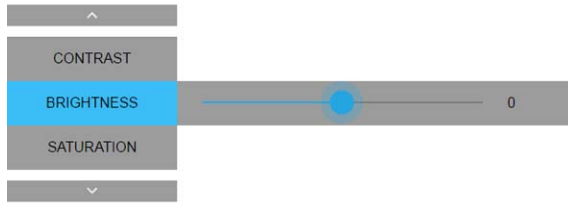

Image 7-4  
Brightness slider

3. Use the ▲ or ▼ key to select *Contrast* or *Saturation*.  
Or,  
go to *Home - Image* and select *Contrast* or *Saturation*.

### How to set up Saturation Level

1. In the main menu, select *Image* → *Saturation*.



SATURATION

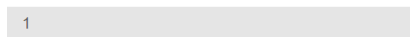

Image 7-5  
Image menu — Saturation

2. Use the ◀ or ▶ key to change the saturation until the desired value is reached (adjustable between -1 and 1).

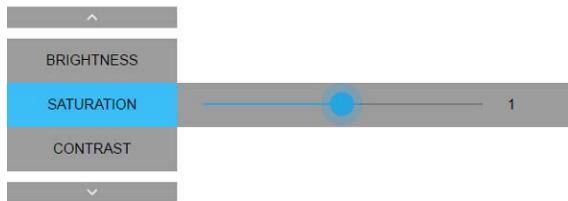

Image 7-6  
Saturation slider

3. Use the ▲ or ▼ key to select *Brightness* or *Contrast*.  
Or,  
go to *Home - Image* and select *Brightness* or *Contrast*.

## 7.2 P7 Realcolor

---

### Purpose

When blending images from multiple projectors, the measured color coordination of each projector can be altered to a desired common level. This so that the projected colors are identical over all projectors used.

### How to set the P7 desired values

1. In the main menu, select *Image* → *Advanced* → *P7 Realcolor*.



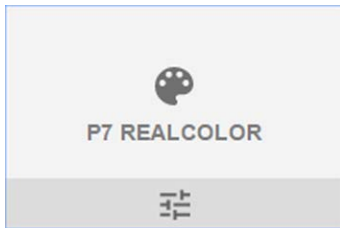

Image 7-7  
Advanced menu — P7 Realcolor

The P7 menu is displayed.

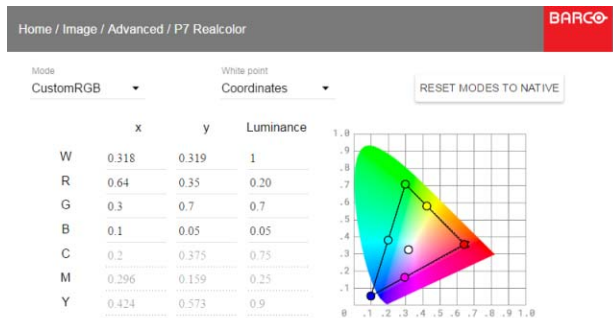

Image 7-8  
P7 Realcolor menu

2. Select the desired *Mode*. Choose one of the following:
  - **Native**: Default mode, with default values. All other options in the P7 menu are disabled.
  - **Custom RGB**: 3–point color configuration. In RGB mode, the C, M and Y coordinates will be calculated automatically based on the R, G and B coordinates.
  - **Custom RGBCMY**: 6–point color configuration (both RGB and CMY). In RGBCMY mode, each color can be given a specific coordinate within the measured color triangle.
  - **Custom WHITE**: Configure only the White temperature.
3. Define the coordinates for each available color.  
Click on a coordinate value and select the current value. Enter the desired value with the numeric keys.  
**Note:** You can only pick coordinates within the measured color triangle.
4. For **Custom White**, click on White point and choose one of the following:
  - **Coordinates**: Configure the white point via specific coordinates. The white point is specified using an x, y coordinate in the CIE 1931 Chart.
  - **Temperature**: Configure the white point via a color temperature slider. The white point is specified on a Kelvin scale between 3200K and 13000K tracking along the black body curve.



You can reset all coordinates to the default values (to native) by selecting **Reset modes to native**. Press **OK** button to reset.

## 7.3 HDR – Perceptual Quantizer (PQ)

### About PQ

Perceptual Quantizer (PQ) is a, electro-optical transfer function (EOTF) that allows for the display of High Dynamic Range (HDR) content with a luminance level of up to 10 000 cd/m<sup>2</sup> and can be used with the Rec. 2020 color space.

If your provided HDR content has been mastered with Perceptual Quantizer (e.g. Dolby Vision or HDR10), you can adapt the luminance on screen to adapt to the provided content.



For optimal display of HDR content, this is just one value that will influence the projected image. When entering the desired screen luminance, take into account the distance of the projector to the screen and the quality of the screen used.

### How to set the PQ?

1. In the main menu, select *Image* → *Advanced* → *PQ*.



Image 7-9

The PQ menu is displayed

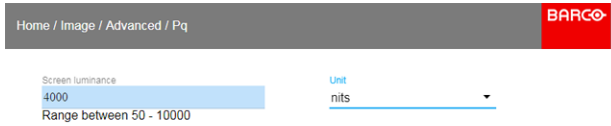

Image 7-10

2. Select the desired Unit (nits or foot-lambert).
3. Enter the Screen luminance (either in nit, or foot-lambert).

## 8. GUI – INSTALLATION

Overview of features

- Configuring the lens, shift
- Orientation
- Warping
- Blending
- Laser illumination
- Active 3D Set up

### 8.1 Configuring the lens, shift

#### What can be done?

The image can be shifted by using the vertical and horizontal lens shift.



**Lens shift is only possible when lens shift is calibrated. Please refer to the lens calibration section in *System Settings* → *Lens Calibration* menu.**

#### Vertical and Horizontal Shift

1. To change the position of the projected image, select *Installation* → *Lens* → *Shift*.



Image 8-1  
Lens menu, Lens shift

2. Use the ▲ or ▼ key to shift the lens (image) in vertical direction.  
Use the ◀ or ▶ key to shift the lens (image) in horizontal direction.

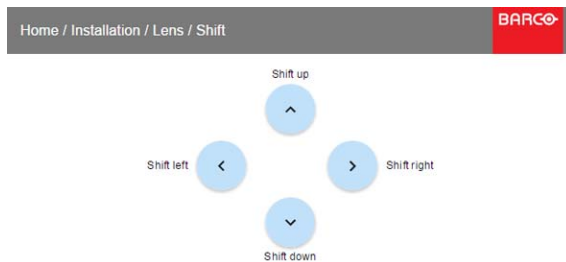

Image 8-2  
Shift adjustment

### 8.2 Orientation

#### What can be done?

The way of physical installation of the projector can be defined to the projector.

The following installation are possible:

- front/table
- front/ceiling
- rear/table
- rear/ceiling

### How to set the correct orientation

1. In the main menu, select *Installation* → *Orientation*.



Image 8-3  
Installation menu, Orientation

The Orientation menu is displayed.

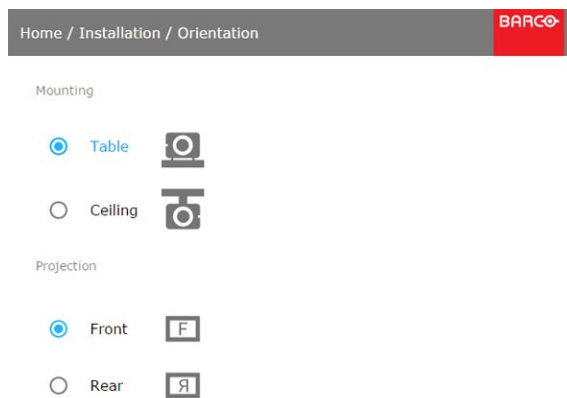

Image 8-4  
Orientation menu

2. Use the ▲ or ▼ key to select the desired mounting position and press **OK** button to activate.  
Use the ▲ or ▼ key to select the desired projection position and press **OK** button to activate.

## 8.3 Warping

---

### 8.3.1 About warping

#### Overview

Image warping is the process of digitally manipulating an image to compensate for the distortion of the screen. Consequently, it can also be used to generate an image with irregular shape.

While an image can be transformed in various ways, pure warping doesn't affect the colors.

### 8.3.2 Warping – On/Off

#### About warping on/off

By toggling between on and off the warping functionality can be enabled or disabled.

#### How to toggle

1. In the main menu, select *Installation* → *Warp*.

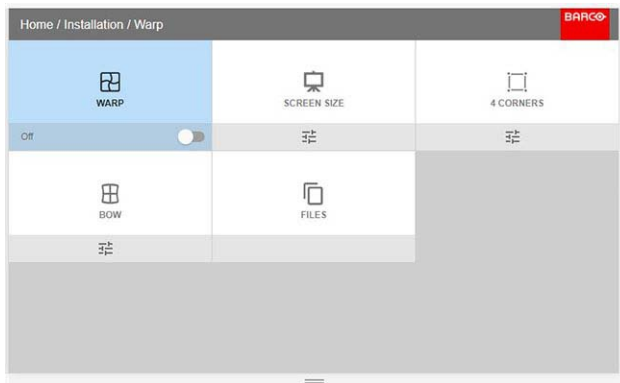

Image 8-5

2. In the Warp menu, click *Warp* to toggle between *On* and *Off*.



Image 8-6



Image 8-7

### 8.3.3 Warping – Screen Size

#### About (Warp) Screen Size adjustment

If the used source aspect ratio is different than the projector aspect ratio, e.g. source is 16:9 and projector is 16:10, then black bars will be projected. In the example case a black bar on top and bottom of the image will be projected. The warp area contains not only the image information but also the black bars. If we want to position e.g. the active left top corner exactly on the screen using 4 corner warp, then it is very hard to do that as we are moving the black left top corner and we do not have control over the exact position of image left top corner. By moving the outline of the warp screen size to the active image information, the corner points of the warp area are now exactly on the corner points of the active image information and makes warping much easier.

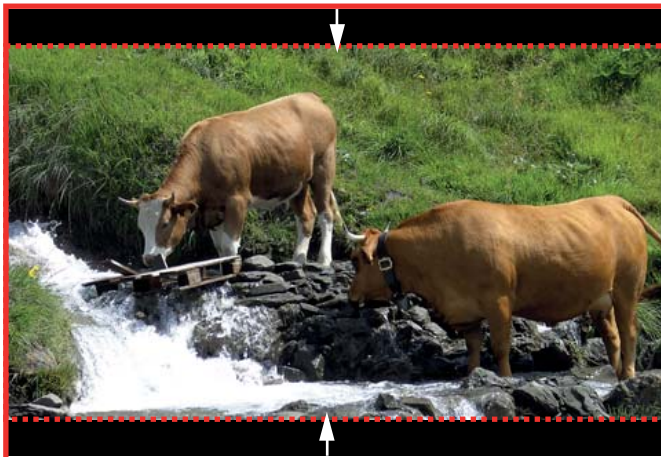

Image 8-8  
Warp outline example

#### How to adjust the image?

1. In the main menu, select *Installation* → *Warp* → *Screen Size*.

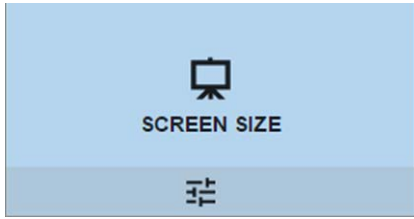

Image 8-9  
Warp Menu, Screen Size

The Screen Size menu is displayed.

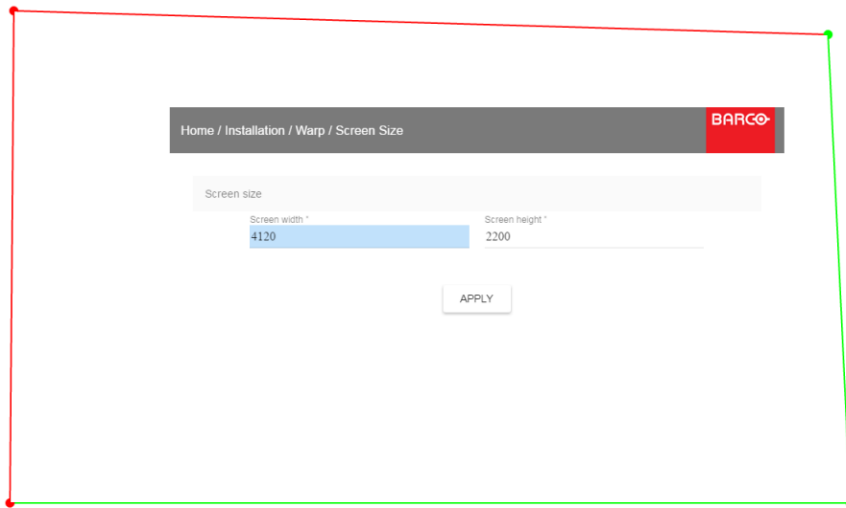

Image 8-10  
Screen size

2. Select either *Screen width* or *Screen height*.
3. Set the new value to shrink either the width or height of the warp outline so that the outline is equal with the active source.  
**Tip:** A red border will be projected along with the current image. The border is a visual tool, showing the result of the adjusted outline.
4. Click **Apply**.

### 8.3.4 Warping – 4 corners adjustment

#### About 4 Corners adjustment

4 corner adjustment is typically used when the mechanical installation of the projector prevents it from pointing perpendicularly at the screen. For example, you can overshoot the screen and use 4 corner adjustment to pull your projected image corners back into the screen.

Some examples:



Image 8-11  
4 corner adjustment

#### How to adjust the image?

1. In the main menu, select *Installation* → *Warp* → *4 Corners*.



Image 8-12  
Warp menu, 4 Corners

The 4 Corners menu is displayed.

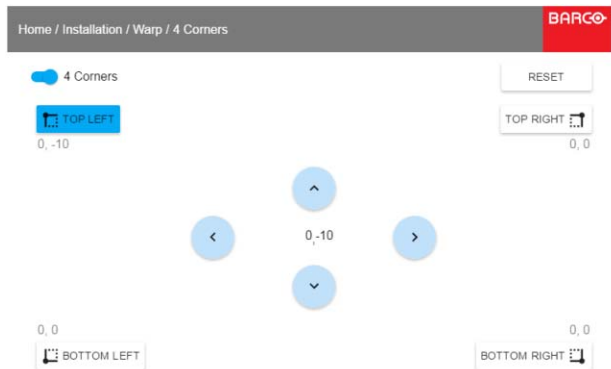

Image 8-13  
4 Corners Warping

2. To enable 4 Corners warping, make sure the *4 corners* slider is set to *On*.  
The slider is enabled when set to the right and when it is colored blue.
3. To set warping on one or more of the four corners, select one of the four corners.
4. Set the desired X and Y coordinates for this corner, using the arrow keys.  
**Tip:** A red border corner will be projected along with the current image. The border is a visual aid, showing the result of the warped corners.
5. Repeat from step 3 for each corner, until all corners are warped in the desired position.



To reset the 4 corner adjustments, select *Reset* and press the *OK* button.

### 8.3.5 Warping – Bow

#### About bow adjustment

A bow distortion can be adjusted so that a normal image is displayed. Positive adjustments introduce more outside bow distortion. Negative adjustments introduce more inside bow distortion.

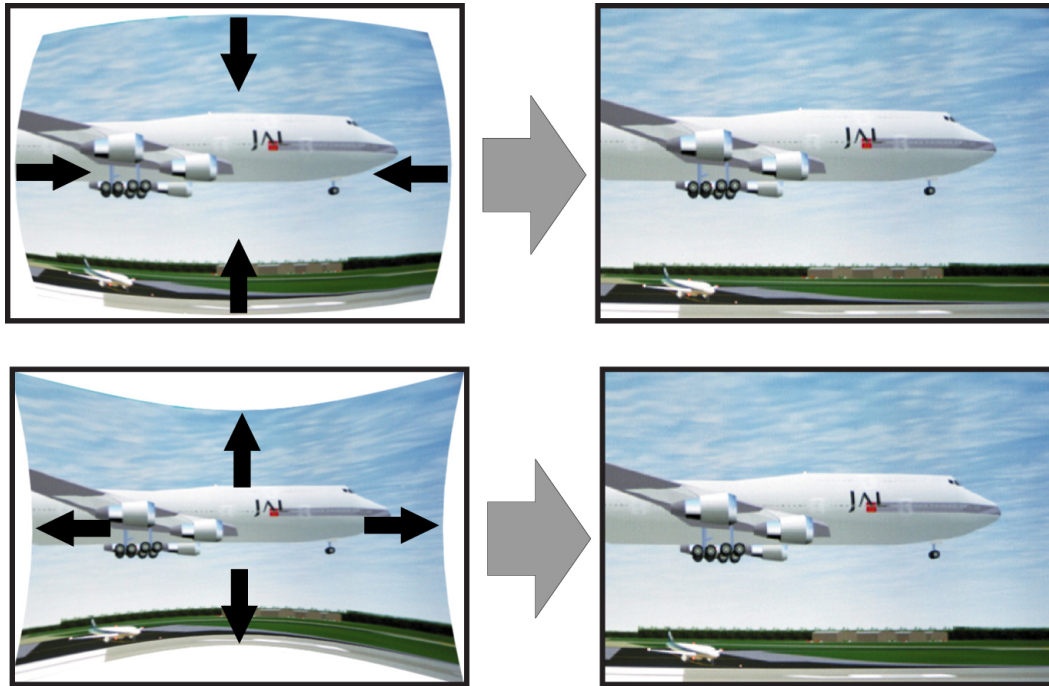

Image 8-14  
Bow distortion

### How to adjust

1. In the main menu, select *Installation* → *Warp*.

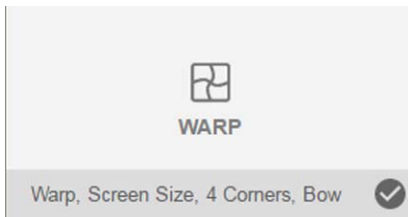

Image 8-15  
Installation menu, Warp

2. In the Warp menu, select *Bow*.



Image 8-16  
Warp menu, Bow

A check symbol at the bottom right corner indicates that the bow function is activated.

3. To enable Bow correction, make sure the *Bow* slider is set to *On*.  
The slider is enabled when set to the right and when it is colored blue.



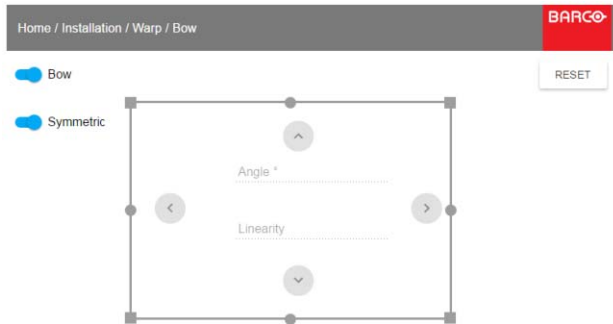

Image 8-17  
Bow adjustment

4. To enable a symmetric adjustment, make sure the *Symmetric* slider is set to *On*.  
The slider is enabled when set to the right and when it is colored blue.
5. Select an adjustment point and use the arrow keys to adjust.  
When selecting a mid point of an edge, the bow angle can be adjusted.  
When selecting a corner point, the linearity can be adjusted.



To reset the bow adjustments, select *Reset* and press the OK button.

### 8.3.6 Warping – Warp files

#### About custom Warp Files

Next to setting your specific warp configuration in the GUI, you can also upload or download a custom warp grid in xml format to/from the projector. This is a time-saving option when multiple projectors need an identical Warp configuration.

To upload or download warp files you can use Projector Toolset or upload/download the warp grid in the format of an xml file. Alternatively, you can contact the “file endpoint” directly via the curl program or some other tool that supports http upload.

For more information on uploading/downloading Warp files using the Projector Toolset, refer to the Projector Toolset user manual.

For more information on uploading/downloading Warp files using curl or other tools that supports HTTP upload, refer to the Pulse API Reference Guide.

#### How to activate an uploaded Warp grid?

1. In the main menu, select *Installation* → *Warp*.

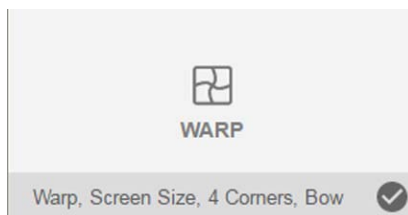

Image 8-18  
Installation menu, Warp

2. In the Warp menu, select *Files*.

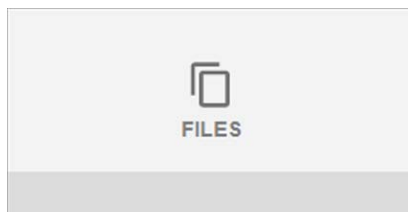

Image 8-19  
Warp menu, Files

The Warp Files menu is displayed.



Image 8-20

3. If any custom Warp files are available, select the desired warp file.



Image 8-21

4. Click on the on/off button on top to activate the selected warp file.



Image 8-22

---

## 8.4 Blending

### About Blending

Blending is used in multi channel installation to have a seamless transition between the channels. Image blending gives the appearance of a single view, thus achieving realistic immersion for the majority of wide screen applications.

The principle is that the light intensity in the blend zone from each projector will be adjusted individually, so that the rendering on the screen are perceived as from one projector.

From the start (offset) position, you can blend zone size per edge (left, top, right, bottom). For each edge there will be a drop-off curve for the blend zone.

## 8.4.1 Blend Zones

### About offset and blending width or height

Offset is used to clip the image. The larger the offset value, the more the image is masked (by black bar) at the corresponding side. E.g. Top offset of 100 will blank the top 100 lines.

Height or width is used to create a blending zone with a smooth brightness drop off. This is used to compensate for the double brightness in overlap areas. The value is the size of the blended area in pixels.

### How to adjust blend zones?

1. In the main menu, select *Installation* → *Blend* → *Blend Zones*.



Image 8-23  
Blend menu, Zones

The Blend zones menu is displayed

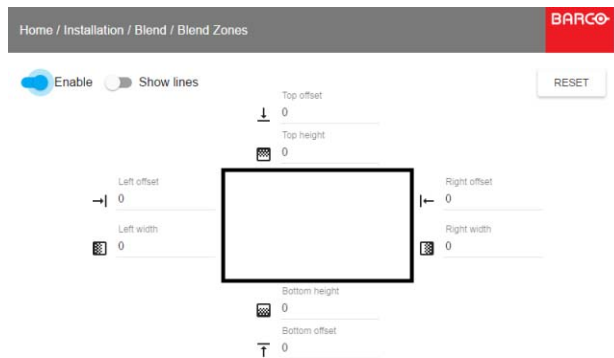

Image 8-24  
Blend Zone menu

2. To enable blending, put the switch to the right. The color of the switch becomes blue when activated.
3. To show blending lines on the screen, put the switch before Show lines to the right. The color of the switch becomes blue when activated.
4. Specify the start position (offset)(1) for the blending height and width, setup an size value (2) to determine the width of the blending area.

When the blending lines are activated, you will get a visual indication of the screen of the installed blending area.

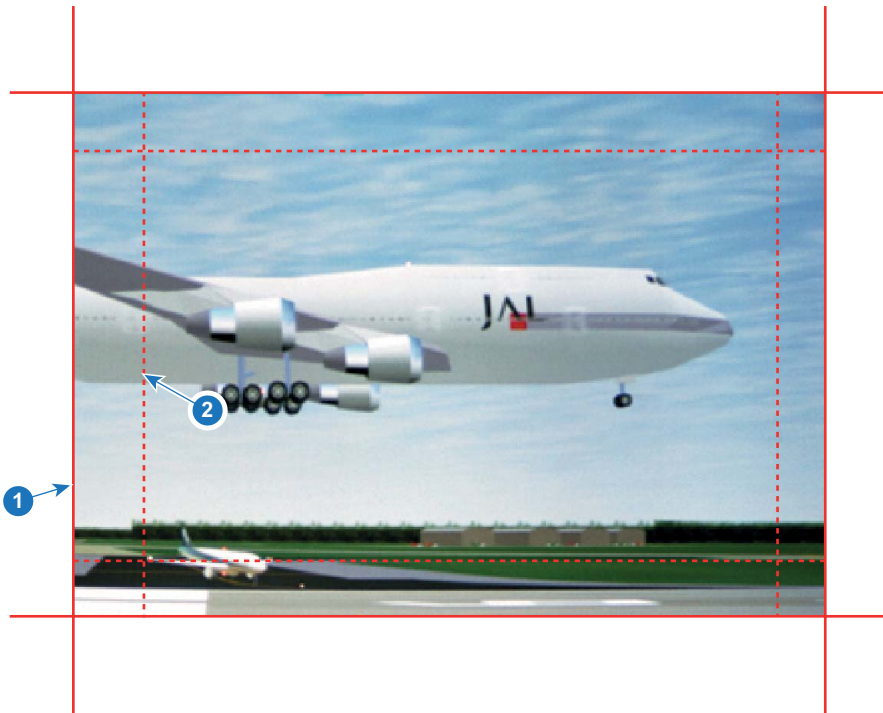

Image 8-25

- 1 Start position (offset)
- 2 Blending width

- 5. First select an offset and click **Menu selection** to activate the selection. Use the arrow keys to change the value (the start position of the blending) Repeat for the other edges if necessary.
- 6. Select the height or width and setup a size value. Repeat for the other edges if necessary. The value will range from 0 to 1.0 (linear to S-curved), with a default value of 0.5.

### Example of the use of blending

When projecting an image with 2 projectors, there is always an small overlap that should be corrected by using the blending function.



**In order to obtain a satisfying result for the Blend function, the overlap / Blend zone are recommended to be at least 10% of the picture width.**

The basic principle is that the overlap setup in the source shall correspond with the blend width setup for the projector. That means that if the overlap zone for the source is set to 500 pixels, the width of the blend zone for the projector also must be set to 500 pixels.

First step is to align the image from the projectors as accurate as possible in a mechanical way, meaning without any optical corrections. At the same time, establish an overlap in the pictures between the two screens.

Then adjust the remaining irregularities by using the shift and warp features in the projectors to obtain the last fine tuning of the alignment.

Enable blending and activate Show lines.

First set the blending width for the right edge of the first projector. Enter a width value equal to the overlap area (width1).

Repeat for the left edge of the second projector.

Adjust the offset to cut the image on each side (masking).

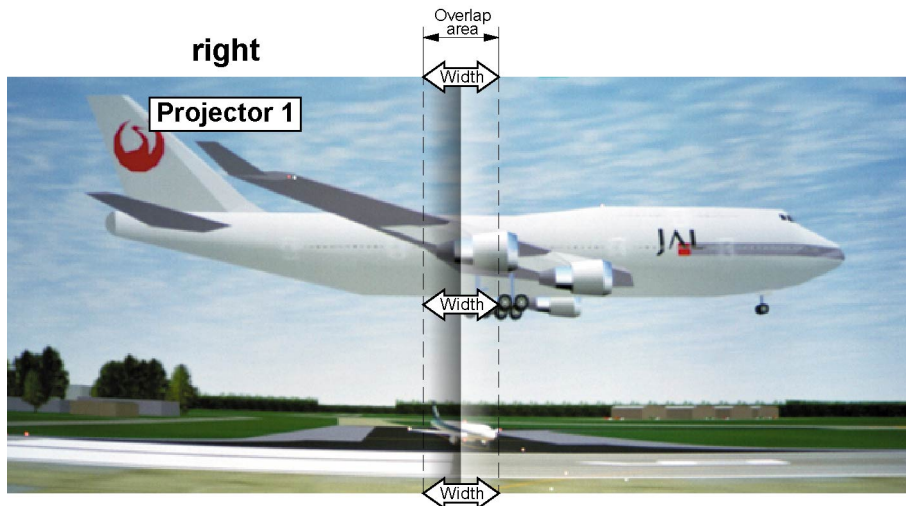

Image 8-26  
Set up for projector 1

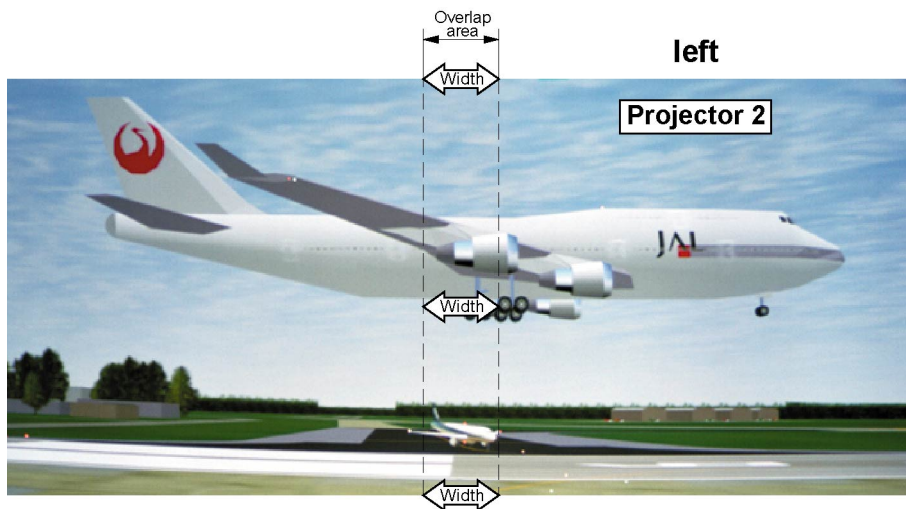

Image 8-27  
Set up for projector 2

## 8.4.2 Black level adjustment

### About adjusting the black level

The purpose of the black level adjustment is to align the black levels in the overlapped regions with the black levels in the other regions.

This is needed because the black levels will be brighter in the blend zones, since multiple projectors will project on the same screen area.

The size of the black level area is calculated automatically from the blend zones. This is done by using the start position and size of each edge of the blend and adding an additional size of 8 pixels to reduce the effect known as "sea of mirrors".

You can also specify the offsets manually by turning off the automatic calculation. The black level value is adjusted in a 8 bit resolution from 0 to 255.

### How to adjust the black level manually

1. In the main menu, select *Installation* → *Blend*.

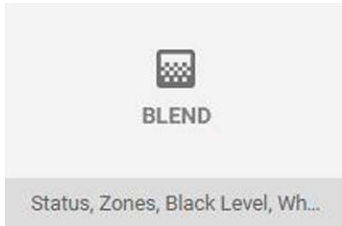

Image 8-28  
Installation menu, Blend

2. In the Blend menu, select *Black Level*.



Image 8-29  
Blend menu — Black level

The Black Level menu is displayed.

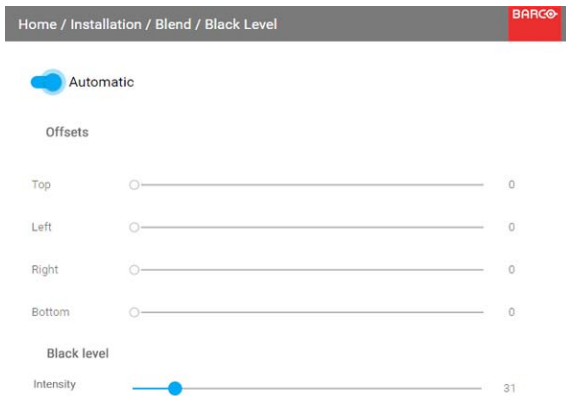

Image 8-30  
Black Level menu

3. To manually change the black levels, disable the **Automatic** slider on top of the menu.
4. Slide the **Offset** sliders to the desired position. You can change the offset for top, bottom, left and right edge.
5. Slide the Intensity slider to the desired position.

### 8.4.3 Black Level Files

#### About custom Black Level Files

Next to setting your specific Black Level Adjustment in the GUI, you can also upload or download a custom Black Level adjustment file in xml format to/from the projector.

To upload or download Black Level adjustment files you can use Projector Toolset or upload/download the Black Level adjustment file in the format of an xml file. Alternatively, you can contact the “file endpoint” directly via the curl program or some other tool that supports http upload.

For more information on uploading/downloading Black Level files using the Projector Toolset, refer to the Projector Toolset user manual.

For more information on uploading/downloading Black Level files using curl or other tools that supports HTTP upload, refer to the Pulse API Reference Guide.

#### How to activate an uploaded Black Level adjustment file?

1. In the main menu, select *Installation* → *Blend*.

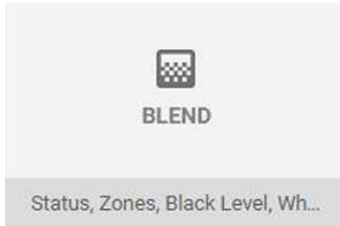

Image 8-31  
Installation menu, Blend

- In the Blend menu, select Black Level Files.

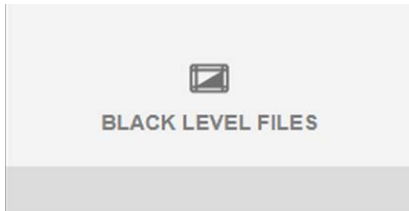

Image 8-32  
Blend menu, Black Level Files

The Black Level Files menu is displayed.

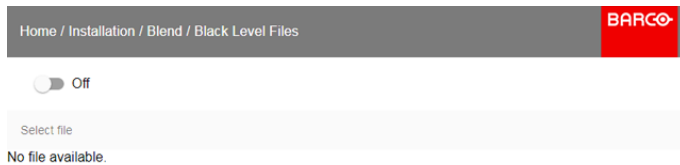

Image 8-33

- If any custom Black Level adjustment files are available, select the desired file.



Image 8-34

- Click on the on/off button on top to activate the selected Black Level adjustment file.

#### 8.4.4 Blend Files

##### About custom Blend Files

Next to setting your specific Blending configuration in the GUI, you can also upload or download a custom Blend configuration file in xml format to/from the projector. This is a time-saving option when multiple projectors need an identical blending configuration.

To upload or download Blend configuration files you can use Projector Toolset or upload/download the Blend configuration file in the format of an xml file. Alternatively, you can contact the “file endpoint” directly via the curl program or some other tool that supports http upload.

For more information on uploading/downloading Blend files using the Projector Toolset, refer to the Projector Toolset user manual.

For more information on uploading/downloading Blend files using curl or other tools that supports HTTP upload, refer to the Pulse API Reference Guide.

### How to activate an uploaded Blend configuration file?

1. In the main menu, select *Installation* → *Blend*.

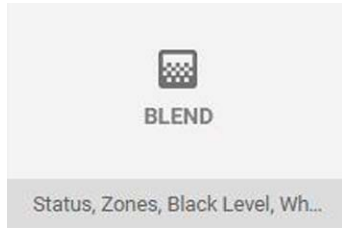

Image 8-35  
Installation menu, Blend

2. In the Blend menu, select Blend Files.

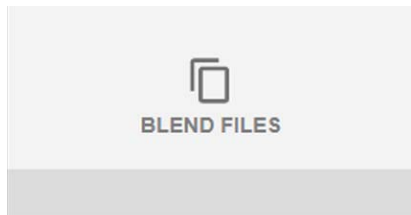

Image 8-36  
Blend menu, Blend Files

The Blend Files menu is displayed.



Image 8-37

3. If any custom Blend files are available, select the desired file.

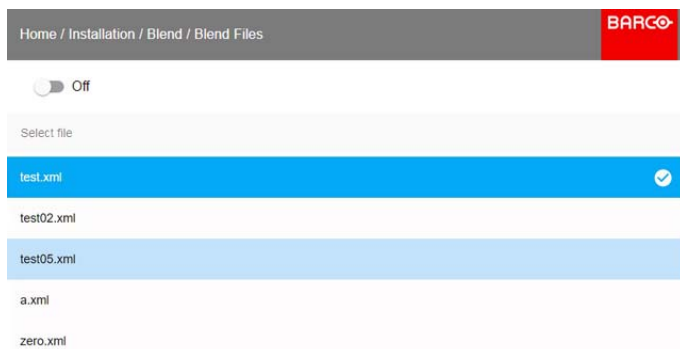

Image 8-38

4. Click on the on/off button on top to activate the selected Blend file.



## 8.5 Laser illumination

### What can be done?

Within a certain power mode, the light output of the laser can be reduced by reducing the laser power.

### How to reduce the power

1. In the main menu, select *Installation* → *Illumination* → *Power*.

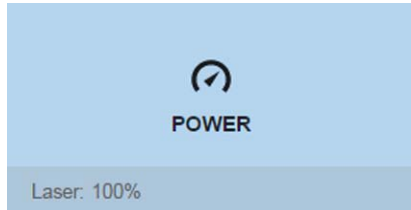

Image 8-39  
Illumination menu, Power

The actual power setting is indicated at the bottom of the *Power* button.

2. Use the Slider to change the power value.



Image 8-40  
Laser power adjustment

## 8.6 Active 3D Set up

### About active 3D

The projector supports active 3D, in combination with a 3D emitter and compatible battery-operated shutter glasses. The options on the projector allow you to fine-tune the 3D settings accordingly to the specifications of the 3D emitter.



**If a 3D emitter is used that radiates IR beams, the IR beams may interfere with the IR communication between projector and the RCU. If such interference occurs, connect the RCU to the projector using the remote cable. It is also advised to turn the IR receivers on the projector off to avoid the 3D emitter interference. To turn off the IR receivers, see "Remote control, on/off button", page 14.**

### How to adjust the projector to the 3D emitter?

1. In the main menu, select *Installation* → *3D Set up*.



Image 8-41

The 3D set up menu is displayed

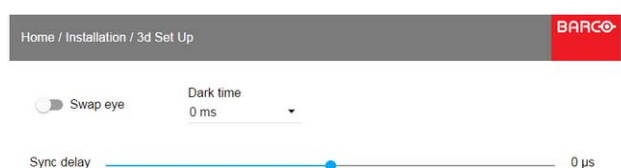

Image 8-42

## 8. GUI – Installation

---

2. Select the desired the stereo Dark Time.
3. Use the slider to set the desired stereo sync delay.
4. If necessary to invert the stereo sync, click the Swap Eye option.

## 9. GUI – SYSTEM SETTINGS

Overview of features

- Communication
- Themes
- Standby ECO
- Service Menu
- Reset

### 9.1 Communication

#### About a network connection

Network connection is required to communicate with the projector via LAN or Internet. The setup could be done manually (set address, subnet mask and default gateway according to network specification), or automatically assign (DHCP).

#### 9.1.1 Introduction to a Network connection



##### DHCP

Dynamic host configuration protocol. DHCP is a communications protocol that lets network administrators manage centrally and automate the assignment of IP addresses in an organization's network. Using the Internet Protocol, each machine that can connect to the Internet needs a unique IP address. When an organization sets up its computer users with a connection to the Internet, an IP address must be assigned to each machine. Without DHCP, the IP address must be entered manually at each computer and, if computers move to another location in another part of the network, a new IP address must be entered. DHCP lets a network administrator supervise and distribute IP addresses from a central point and automatically sends a new IP address when a computer is plugged into a different place in the network.



##### IP

Internet Protocol. The network layer of TCP/IP. Required for communication with the internet.



##### Subnet mask

A number that is used to identify a subnetwork so that IP addresses can be shared on a local area network.



##### Default Gateway

A router that serves as an entry point into and exit point out of a network. For example, a local network (LAN) may need a gateway to connect it to a wide area network (WAN) or to the Internet.



##### MAC address

Media Access Control address. Unique hardware number, used in combination with the IP-address to connect to the network (LAN or WAN).

#### What should be set up for an Ethernet address?

Two ways can be used to assign an address:

- use the *Automatic* setting so that an automatic address will be assigned.
- Assign manually an IP address, Net-mask (subnet-mask), (default) gateway address.
  - Set the IP-Address field to the desired value. This must NOT be 0.0.0.0 for static IP-Address assignment. The IP address identifies a projector's location on the network in the same way a street address identifies a house on a city block. Just as a street address must identify a unique residence, an IP address must be globally unique and have a uniform format.
  - Set the Subnet-Mask as appropriate for the local subnet.
  - Set the Default-Gateway to the IP-Address of the local router (MUST be on the local subnet!) on the same network as this projector that is used to forward traffic to destinations beyond the local network. This must not be 0.0.0.0. If there is no router on the projector's local subnet then just set this field to any IP-Address on the subnet.

### 9.1.2 Wired IP address set up

#### How to automatically set up the IP address

1. In the main menu, select *System Settings* → *Communication* → *LAN*.



Image 9-1  
Communication menu, LAN

The LAN menu is displayed



Image 9-2  
LAN menu

2. To enable Automatic, put the switch to the right. The color of the switch becomes blue.  
An automatic IP is assigned.  
When connected, it is indicated with the connection symbol and the indication *Connected*.
3. Select **APPLY** and click **OK**.

#### How to manually set up the IP address

1. In the main menu, select *System Settings* → *Communication* → *LAN*.



Image 9-3  
Communication menu, LAN

The LAN menu is displayed

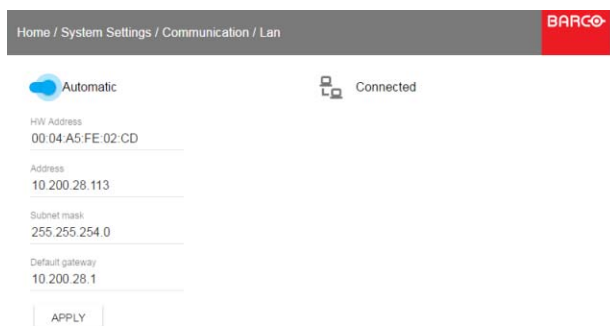

Image 9-4  
LAN menu

2. Disable Automatic. Put the switch to the left. The switch becomes gray.
3. Use the ▲ or ▼ key to select *Address* and press **OK** button to activate the input box.
4. Use the ▲ or ▼ key to change the selected character.  
Use the ◀ or ▶ key to select another character.  
**Note:** *Digits can be entered with the digit keys on the remote control or the local keypad. When a digit is entered in that way, the next character will be selected automatically.*
5. Repeat steps 4 and 5 for the Subnet mask and Default Gateway.
6. Select **APPLY** and click **OK** to confirm all changes.  
When the connection is established, it is indicated with the connection symbol and the indication *Connected*.

## 9.2 Themes

### About Themes

Themes are used to apply a predefined functionality to the OSD display. There are two options: light (default) or dark.

### How to select a different interface theme

1. In the main menu, select *System Settings* → *Themes*.

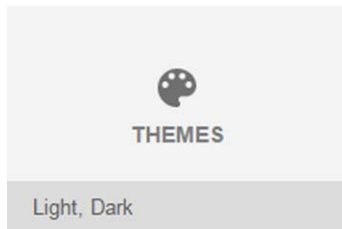

Image 9-5  
System Settings Menu — Themes.

2. In the themes menu, select the desired *Theme*.  
You can choose one of the following: *Light*, or *Dark*.

## 9.3 Standby ECO

### About Standby ECO

When the ECO mode is enabled, the projector will automatically go to **ECO standby** mode after a time-out (default 15 minutes). All electronics (including fans, pumps, ...) go down except for a very small wake-up controller. See section dedicated to the Power Mode transitions for further details.

### How to enable the ECO mode

1. In the main menu, select *System Settings* → *Standby ECO*.

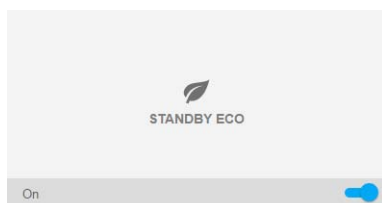

Image 9-6  
System Settings Menu — Standby ECO

2. To enable the ECO mode, make sure the Bow slider is set to On. The slider is enabled when set to the right and when it is colored blue.

### How to disable the ECO mode

1. In the main menu, select *System Settings* → *Standby ECO*.

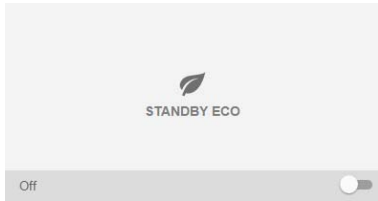

Image 9-7

2. To disable the ECO mode, make sure the Bow slider is set to Off. The slider is disabled when set to the left and when it becomes grey.

## 9.4 Service Menu

### About the service menu

The service menu can only be entered with a *Service code*.

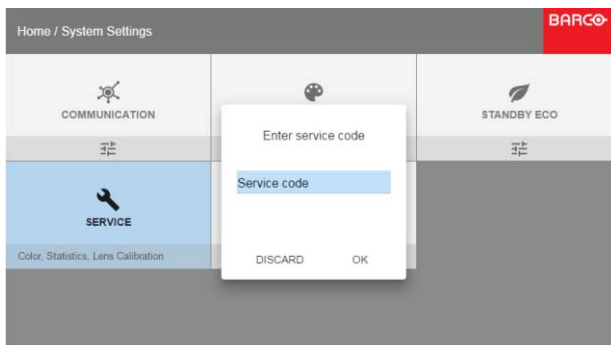

Image 9-8  
Service code

If you have a service code, select *Service code* with the arrow keys and click **OK** to enter the entry mode. Enter the code with the numeric keys and select **OK** and click **OK** on to confirm. Otherwise select **DISCARD** and click **OK** to return to the *System Settings* menu.

### Overview

- Service – Color Wheel
- Service – Color
- Service – Statistics
- Lens Calibration
- Lens features
- Service – Pixel Shift

#### 9.4.1 Service – Color Wheel

##### About Color Wheel

F80 is equip with only one Color Wheel which is controlled by the software. However, via the service menu, a Slider makes possible a fine-tuning for variation on the Color Wheel.

##### How to fine-tuning

1. In the main menu, *System Settings* → *Service*.

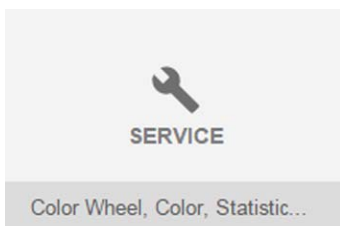

Image 9-9

2. Enter the service code.

- In the Service menu, select *Color Wheel*.

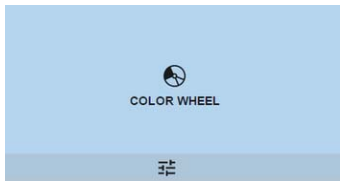

Image 9-10

The Color Wheel menu will be displayed.

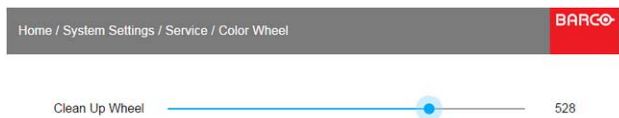

Image 9-11

- Change the values to the desired position.

## 9.4.2 Service – Color



**CAUTION:** The native colors have been measured and set during factory production. Do not change them, unless parts of the optical path have been replaced due to servicing.

If you need to change the native colors on the device, make sure to also perform a P7 calibration, using the Projector Toolset and a chroma meter. For more info on P7 calibration, refer to the Projector Toolset Reference guide.

### How to adjust the P7 native settings

- In the main menu, *System Settings* → *Service*.

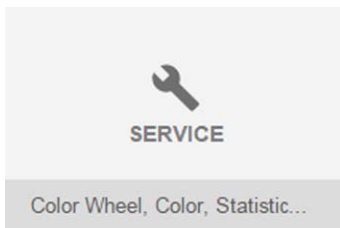

Image 9-12

- Enter the service code.
- In the Service menu, select *Color*.



Image 9-13

The Color menu will be displayed.

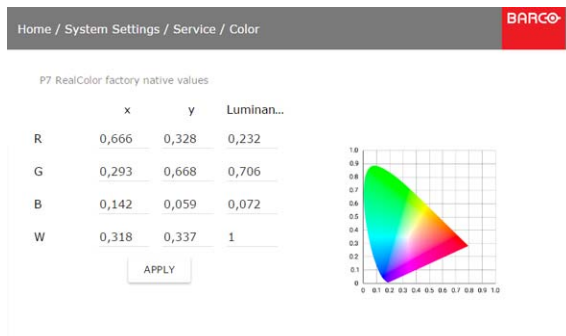

Image 9-14

4. Select the desired value to change and confirm.
5. Change the values to the desired position, taking into account the color gamut values.
6. Select **APPLY** and click **OK**.

### 9.4.3 Service – Statistics

#### What can be seen?

The statistics screen shows the general information about the projector.

The following items will be displayed:

- Laser runtime
- Laser Strikes
- Projector Runtime
- System time
- Current Uptime
- Pump Runtime

#### How to display the statistics

1. In the main menu, *System Settings* → *Service*.

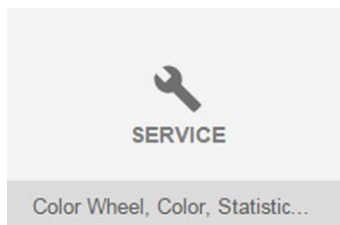

Image 9-15

2. Enter the service code.
3. In the Service menu, select *Statistics*.

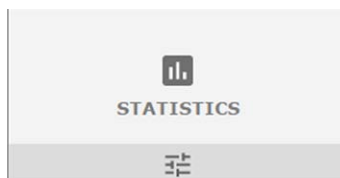

Image 9-16



The Statistics will be displayed.

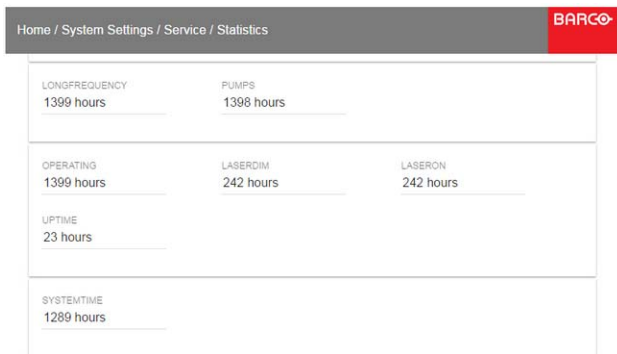

Image 9-17

## 9.4.4 Lens Calibration



Lens calibration is a time consuming operation.

### How to calibrate

1. In the main menu, *System Settings* → *Service*.

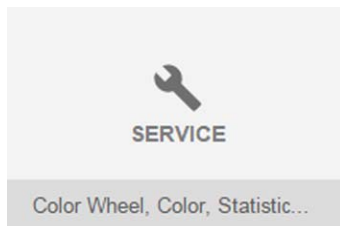

Image 9-18

2. Enter the service code.
3. In the *Service* menu, select *Lens Calibration*.

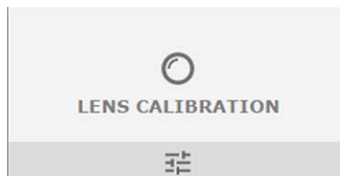

Image 9-19  
System Settings menu — Lens Calibration

The Lens Calibration menu is displayed.

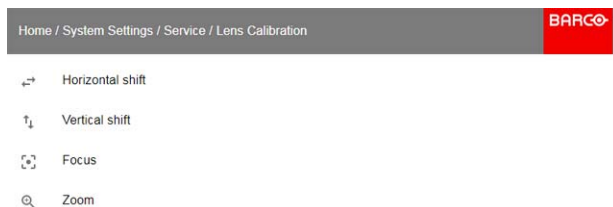

Image 9-20  
Lens Calibration menu

4. In the Lens Calibration menu, select the desired calibration action and click **OK**.  
You can select one of the following functions:

- Horizontal shift
- Vertical shift
- Focus
- Zoom

The text **Calibration in progress** will be displayed next to selected function until the calibration is completed.

When an error is detected, the message *Calibration Error* is displayed next to function.

### 9.4.5 Lens features

#### What can be done?

Some lens features can be disabled once they are correctly aligned so that a misalignment during a show is not possible.

#### How to enable/disable

1. In the main menu, *System Settings* → *Service*.

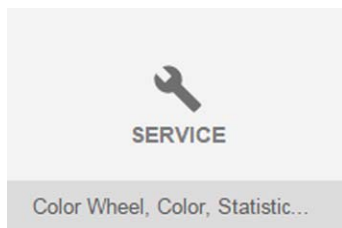

Image 9-21

2. Enter the service code.
3. In the *Service* menu, select *Lens features*.



Image 9-22  
Service menu, lens features

The Lens features menu is displayed.

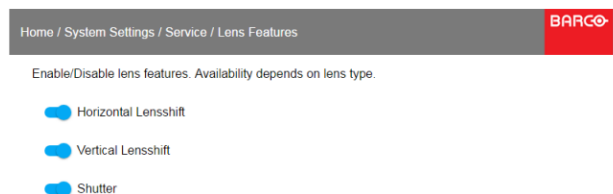

Image 9-23  
Lens features

Depending on the lens type, different functions are available such as:

- Focus
- Horizontal lens shift
- Vertical lens shift
- Shutter
- Zoom

4. To enable/disable a feature, click on the slider and drag it to the left to disable the feature or the right to enable the feature.

When enabled, the slider becomes blue;

When disabled, the slider is gray.

## 9.4.6 Service – Pixel Shift

### About Pixel Shift

This setting allows production to fine tune the wobulator/XPR until the marker is in the 'bullseye'. During the settings, the repetitive on screen pattern 'CROSS HATCH' must be displayed. The maintenance person has to align the both following images with the sliders available in this menu.

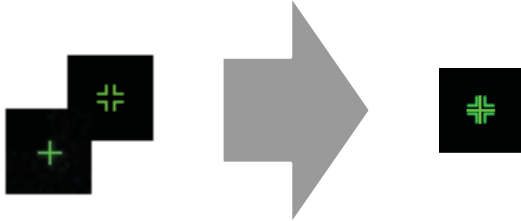

Image 9-24

### How to fine-tuning

1. In the main menu, *System Settings* → *Service*.

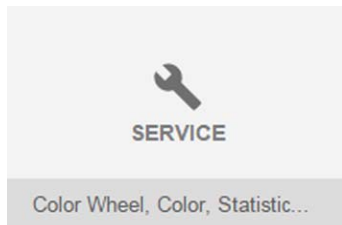

Image 9-25

2. Enter the service code.
3. In the Service menu, select *Pixel Shift*.



Image 9-26

The Pixel Shift menu will be displayed.

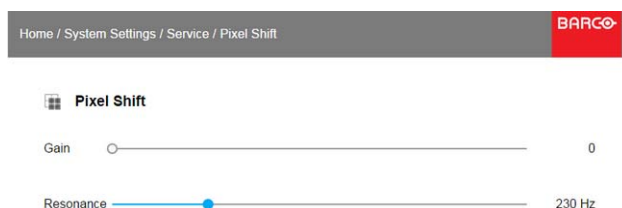

Image 9-27

4. Change the values to the desired position.
  - Gain: is the amplitude of the waveform which is sent into the Wobulator. Default value: 0.65
  - Resonance (frequency) : if frequency is 0Hz the wobulator is of. High frequency means high noise. Default value: 227Hz

## 9.5 Reset

### What can be done?

All settings and values on the projector can be reset to its default values. This can be done for one or more settings separately, or all settings together (factory reset).

### Default settings

The following settings are default settings:

	Setting	Default value
ImageConnector	Color Space	auto
	Signal Range	auto
ImageSource	Source files	Standard
ImageFeatures	Contrast	mid value
	Brightness	mid value
	Saturation	mid value
	Cropping	Off
	Aspect Ratio	16:9
ImageRealColor	P7 Realcolor	all set to native
ImageWarp	Screen size	5120x3200 / 2560x1600
	4 corner	Warp off, no warp
ImageBlend	Blend Width	disabled, all value to zero
	offset	
ImageOrientation	Orientation	Table, Front
ImageResolution	Output Resolution	4K UHD
ImageStereo	Sync delay	0 µs
	Swap eye	Off
	Dark time	lowest value available
UserInterface	Theme	Light
Optics	High Contrast	Off
Illumination	Power	100%
Network	Communication	LAN, Automatic settings
Screen	Screen luminance - Unit	nits
System	Eco Mode (if applicable)	Available
	Ready Timeout	auto

### How to reset all projector settings

1. In the main menu, select *System Settings* → Reset.
2. In the Reset menu, select *RESET ALL* and click **OK**.

### How to reset one or more projector settings

1. In the main menu, select *System Settings* → Reset.

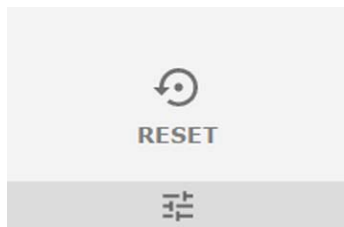

Image 9-28  
System Settings menu, Reset

The Reset menu is displayed.

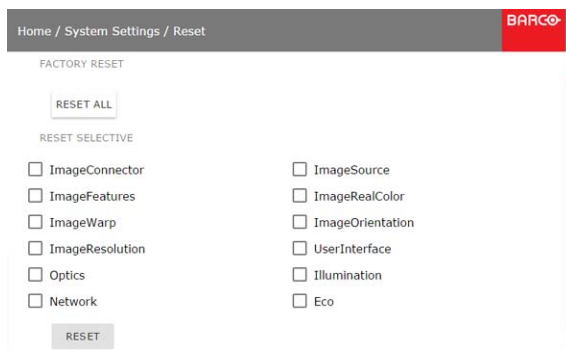

Image 9-29  
Reset menu

2. Navigate to the checkbox next to the settings that need to be reset and press **OK**.  
Multiple selection are possible.
3. Select **RESET** and press **OK** to reset all selected settings.



---

# 10. STATUS MENU



This is a status menu only. No changes can be made to settings from this menu.

---

## Overview

- Status menu overview

---

## 10.1 Status menu overview

### Status menu

While in the main menu, press Status.

### Source status

Displays active source information

### Product

Displays active product information:

- Article number: Projector article / part number
- Serial number: Projector serial number
- Firmware: Projector software package version
- Model name: Projector model name

### Illumination

Shows the used light source power (in %) and runtime.

### Communication

Lists the projector IP address.

### Warp

Displays the Warp status and type of warp used

### Blend

Displays the Warp status and type of Blend used





# 11. MAINTENANCE

## About this chapter

This chapter contains general maintenance procedures.

## Overview

- Cleaning the lens
- Cleaning the exterior of the projector
- Filters

## 11.1 Cleaning the lens



To minimize the possibility of damage to optical coatings, or scratches to lens surfaces follow the cleaning procedure as described here precisely.

### Necessary tools

- Compressed air.
- Clean Toraysee® cloth or any micro fiber lens cleaning cloth.
- Clean cotton cloth.

### Necessary parts

Lens cleaner (e.g. Carl Zeiss lens cleaner or Purasol® or any water-based lens cleaner)

### How to clean the lens?

1. Blow off dust with clean compressed air (or pressurized air cans<sup>1</sup>).
2. Clean with lens cleaner together with a clean lens cleaning cloth to remove the dust and contamination. Use big wipes in one single direction.  
**Warning:** Do not wipe back and forwards across the lens surface as this tends to grind dirt into the coating.
3. Use a dry lens cleaning cloth to remove left liquid or stripes. Polish with small circles.
4. If there are still fingerprints on the surface, wipe them off with lens cleaner together with a clean lens cleaning cloth. Polish again with a dry one.



If smears occur when cleaning lenses, replace the cloth. Smears are the first indication of a dirty cloth.

## 11.2 Cleaning the exterior of the projector

### How to clean the exterior of the projector ?

1. Switch off the projector and unplug the projector from the mains power net.
2. Clean the housing of the projector with a damp cloth. Stubborn stains may be removed with a cloth lightly dampened with a mild detergent solution.

## 11.3 Filters

### General info regarding Air intake and filters.

The F80 is shipped without any filters. The air intake is just protected by a mesh. This mesh has to be vacuum cleaned occasionally when needed. There is no specific interval for this operation.

1. Pressurized air cans are not efficient if there is too much dust on the surface, the pressure is too low



## A. SPECIFICATIONS

### A.1 Specifications of the F80-Q7

#### Overview

<b>Projector type</b>	Single-chip DLP projector
<b>Technology</b>	0.64" DMD
<b>Resolution</b>	2,560 x 1,600 (WQXGA) native
<b>Input resolutions</b>	4,096 x 2,400 max.
<b>Output Resolutions</b>	2,560 x 1,600 (WQXGA)
<b>Brightness</b>	7,000 lumens
<b>Contrast ratio</b>	1,300:1
<b>Aspect ratio</b>	16:10
<b>Optical lens shift</b>	Motorized zoom, focus, vertical and horizontal shift
<b>Throw Ratio</b>	0.85 - 1.06 ; 1.06 - 1.43 ; 1.43 - 2.12 ; 2.12 - 3.18 and compatible with FLD/FLD+ series (with adapter)
<b>Light source</b>	Laser phosphor
<b>Light source lifetime</b>	Up to 40,000 hours
<b>Orientation</b>	360° rotation, no restrictions
<b>Inputs</b>	HDMI, DVI, HDBaseT, DisplayPort, SDI, DMX
<b>Power requirements</b>	100-240V / 50-60Hz
<b>Power consumption</b>	700 W nominal, 850 W maximum
<b>Noise level (typical at 25°C/77°F)</b>	35 dB(A)
<b>Dimensions (WxLxH)</b>	480 x 680 x 227 mm / 18.9 x 26.7 x 8.9 in
<b>Weight</b>	25.5 kg / 56.2 lbs
<b>Certifications</b>	FCC Class A
<b>Warranty</b>	3 years

### A.2 Specifications of the F80-Q9

#### Overview

<b>Projector type</b>	Single chip DLP laser phosphor projector
<b>Technology</b>	0.64" DMD
<b>Resolution</b>	2,560 x 1,600 (WQXGA) native
<b>Input resolutions</b>	4,096 x 2,400 max.
<b>Output Resolutions</b>	2,560 x 1,600 (WQXGA)
<b>Brightness</b>	9,000 lumens
<b>Contrast ratio</b>	1,300:1
<b>Aspect ratio</b>	16:10
<b>Optical lens shift</b>	Motorized zoom, focus, vertical and horizontal shift
<b>Throw Ratio</b>	0.85 - 1.06 ; 1.06 - 1.43 ; 1.43 - 2.12 ; 2.12 - 3.18 and compatible with FLD/FLD+ series (with adapter)
<b>Light source</b>	Laser phosphor
<b>Light source lifetime</b>	Up to 40,000 hours

## A. Specifications

<b>Orientation</b>	360° rotation, no restrictions
<b>Inputs</b>	HDMI, DVI, HDBaseT, DisplayPort, SDI, DMX
<b>Power requirements</b>	100-240V / 50-60Hz
<b>Power consumption</b>	950 W nominal, 1,100 W maximum
<b>Noise level (typical at 25°C/77°F)</b>	35 dB(A)
<b>Dimensions (WxLxH)</b>	480 x 680 x 227 mm / 18.9 x 26.7 x 8.9 in
<b>Weight</b>	25.5 kg / 56.2 lbs
<b>Certifications</b>	FCC Class A
<b>Warranty</b>	3 years

### A.3 Specifications of the F80-4K7

#### Overview

<b>Projector type</b>	4K Single chip DLP laser phosphor projector
<b>Technology</b>	0.64" DMD
<b>Resolution</b>	2,560 x 1,600 (WQXGA) native
<b>Input resolutions</b>	4,096 x 2,400 max.
<b>Output Resolutions</b>	2,560 x 1,600 (WQXGA) ; 3,840 x 2,400 (16:10) ; 3,840 x 2,160 (16:9) ; 4,096 x 2,160 (DCI)
<b>Brightness</b>	7,000 lumens
<b>Contrast ratio</b>	1,300:1
<b>Aspect ratio</b>	16:10
<b>Optical lens shift</b>	Motorized zoom, focus, vertical and horizontal shift
<b>Throw Ratio</b>	0.85 - 1.06 ; 1.06 - 1.43 ; 1.43 - 2.12 ; 2.12 - 3.18 and compatible with FLD/FLD+ series (with adapter)
<b>Light source</b>	Laser phosphor
<b>Light source lifetime</b>	Up to 40,000 hours
<b>Orientation</b>	360° rotation, no restrictions
<b>Inputs</b>	HDMI, DVI, HDBaseT, DisplayPort, SDI, DMX
<b>Power requirements</b>	100-240V / 50-60Hz
<b>Power consumption</b>	700 W nominal, 850 W maximum
<b>Noise level (typical at 25°C/77°F)</b>	35 dB(A)
<b>Dimensions (WxLxH)</b>	480 x 680 x 227 mm / 18.9 x 26.7 x 8.9 in
<b>Weight</b>	25.5 kg / 56.2 lbs
<b>Certifications</b>	FCC Class A
<b>Warranty</b>	3 years

### A.4 Specifications of the F80-4K9

#### Overview

<b>Projector type</b>	4K Single chip DLP laser phosphor projector
<b>Technology</b>	0.64" DMD
<b>Resolution</b>	2,560 x 1,600 (WQXGA) native
<b>Input resolutions</b>	4,096 x 2,400 max.
<b>Output Resolutions</b>	2,560 x 1,600 (WQXGA) ; 3,840 x 2,400 (16:10) ; 3,840 x 2,160 (16:9) ; 4,096 x 2,160 (DCI)

<b>Brightness</b>	9,000 lumens
<b>Contrast ratio</b>	1,300:1
<b>Aspect ratio</b>	16:10
<b>Optical lens shift</b>	Motorized zoom, focus, vertical and horizontal shift
<b>Throw Ratio</b>	0.85 - 1.06 ; 1.06 - 1.43 ; 1.43 - 2.12 ; 2.12 - 3.18 and compatible with FLD/FLD+ series (with adapter)
<b>Light source</b>	Laser phosphor
<b>Light source lifetime</b>	Up to 40,000 hours
<b>Orientation</b>	360° rotation, no restrictions
<b>Inputs</b>	HDMI, DVI, HDBaseT, DisplayPort, SDI, DMX
<b>Power requirements</b>	100-240V / 50-60Hz
<b>Power consumption</b>	950 W nominal, 1100 W maximum
<b>Noise level (typical at 25°C/77°F)</b>	35 dB(A)
<b>Dimensions (WxLxH)</b>	480 x 680 x 227 mm / 18.9 x 26.7 x 8.9 in
<b>Weight</b>	25.5 kg / 56.2 lbs
<b>Certifications</b>	FCC Class A
<b>Warranty</b>	3 years

## A.5 Dimensions of a F80

### Overview

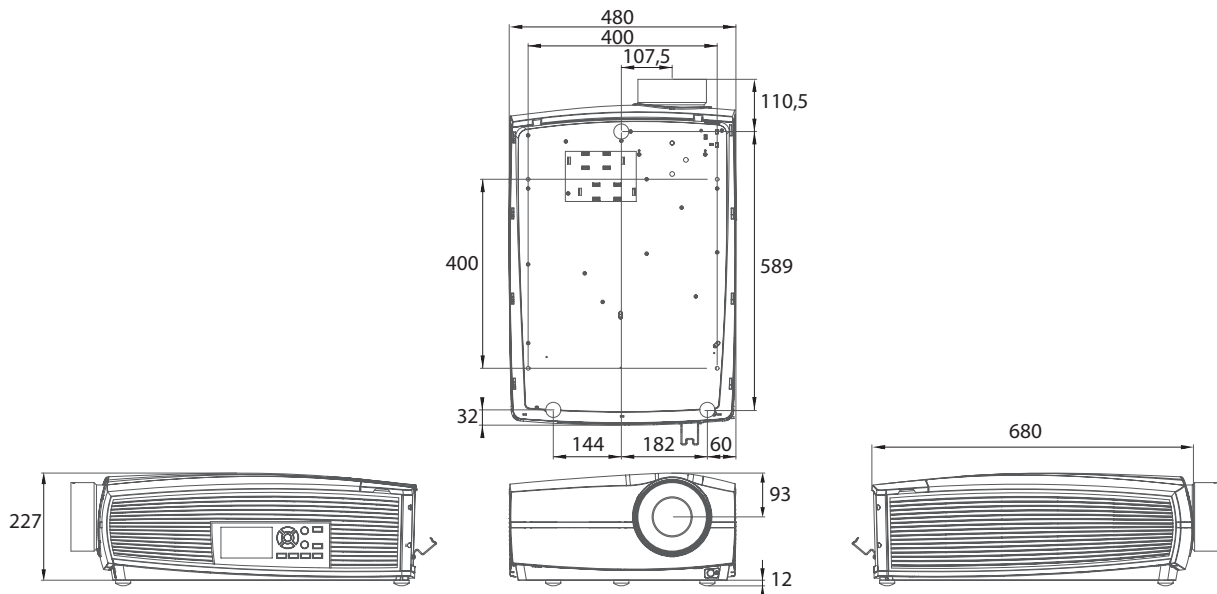

Image A-1  
Dimensions, in mm

## A.6 Technical Regulations

---

### Certificates



Image A-2  
EAC mark



Image A-3  
RoHS



Image A-4  
CE mark



Image A-5  
Nemco mark 60950



Image A-6  
CCC mark



Image A-7  
FCC label



Image A-8  
RCM mark

## B. ENVIRONMENTAL INFORMATION

### Overview

- Disposal information
- China RoHS compliance
- Taiwan RoHS compliance
- Turkey RoHS compliance
- Contact information
- Product Info (Taiwan)

### B.1 Disposal information

#### Disposal Information

Waste Electrical and Electronic Equipment



This symbol on the product indicates that, under the European Directive 2012/19/EU governing waste from electrical and electronic equipment, this product must not be disposed of with other municipal waste. Please dispose of your waste equipment by handing it over to a designated collection point for the recycling of waste electrical and electronic equipment. To prevent possible harm to the environment or human health from uncontrolled waste disposal, please separate these items from other types of waste and recycle them responsibly to promote the sustainable reuse of material resources.

For more information about recycling of this product, please contact your local city office or your municipal waste disposal service.

For details, please visit the Barco website at: <http://www.barco.com/en/AboutBarco/weee>

#### Disposal of batteries in the product



This product contains batteries covered by the Directive 2006/66/EC which must be collected and disposed of separately from municipal waste.

If the battery contains more than the specified values of lead (Pb), mercury (Hg) or cadmium (Cd), these chemical symbols will appear below the crossed-out wheeled bin symbol.

By participating in separate collection of batteries, you will help to ensure proper disposal and to prevent potential negative effects on the environment and human health.

#### WEEE Information

This product conforms to all requirements of the EU Directive on waste electrical and electronic equipment (WEEE). This product shall be recycled properly. It can be disassembled to facilitate proper recycling of its individual parts.

Consult your dealer or relevant public authority regarding drop-off points for collection of WEEE. For details, please visit the Barco website at: <http://www.barco.com/en/aboutBarco/weee>.



**CAUTION: This product contains chemicals, including lead, known to the State of California to cause birth defects or other reproductive harm. Recycle properly, do not dispose of in ordinary waste!**

### B.2 China RoHS compliance

#### 中国大陆 RoHS (Information for China ROHS compliance)

根据中国大陆《电器电子产品有害物质限制使用管理办法》(也称为中国大陆RoHS), 以下部分列出了Barco产品中可能包含的有毒和/或有害物质的名称和含量。中国大陆RoHS指令包含在中国信息产业部MCV标准:“电子信息产品中有毒物质的限量要求”中。

According to the “Management Methods for the Restriction of the Use of Hazardous Substances in Electrical and Electronic Products” (Also called RoHS of Chinese Mainland), the table below lists the names and contents of toxic and/or hazardous substances that Barco’s product may contain. The RoHS of Chinese Mainland is included in the MCV standard of the Ministry of Information Industry of China, in the section “Limit Requirements of toxic substances in Electronic Information Products”.

B. Environmental information

零件项目(名称) Component name	有毒有害物质或元素 Hazardous substances and elements					
	铅 (Pb)	汞 (Hg)	镉 (Cd)	六价铬 (Cr6+)	多溴联苯 (PBB)	多溴二苯醚 (PBDE)
印制电路配件 Printed Circuit Assemblies	X	O	X	O	O	O
外接电(线)缆 External Cables	X	O	O	O	O	O
内部线路 Internal wiring	X	O	O	O	O	O
镜头支架 Lensholder	X	O	O	O	O	O
螺帽,螺钉(栓),螺旋(钉),垫圈,紧固件 Nuts, bolts, screws, washers, Fasteners	X	O	O	O	O	O
激光发生器 Laser	X	O	O	O	O	O
电源供应器 Power Supply Unit	X	O	O	O	O	O
风扇 Fan	X	O	O	O	O	O
附電池遙控器 Remote control	X	O	O	O	O	O
<p>本表格依据SJ/T 11364的规定编制 This table is prepared in accordance with the provisions of SJ/T 11364.</p> <p>O: 表示该有毒有害物质在该部件所有均质材料中的含量均在 GB/T 26572 标准规定的限量要求以下。 O: Indicates that this toxic or hazardous substance contained in all of the homogeneous materials for this part is below the limit requirement in GB/T 26572.</p> <p>X: 表示该有毒有害物质至少在该部件的某一均质材料中的含量超出 GB/T 26572 标准规定的限量要求。 X: Indicates that this toxic or hazardous substance contained in at least one of the homogeneous materials used for this part is above the limit requirement in GB/T 26572.</p>						



在中国大陆销售的相应电子信息产品(EIP)都必须遵照中国大陆《电子电气产品有害物质限制使用标识要求》标准贴上环保使用期限(EFUP)标签。Barco产品所采用的EFUP标签(请参阅实例,徽标内部的编号用于指定产品)基于中国大陆的《电子信息产品环保使用期限通则》标准。  
All Electronic Information Products (EIP) that are sold within Chinese Mainland must comply with the "Marking for the restriction of the use of hazardous substances in electrical and electronic product" of Chinese Mainland, marked with the Environmental Friendly Use Period (EFUP) logo. The number inside the EFUP logo that Barco uses (please refer to the photo) is based on the "General guidelines of environment-friendly use period of electronic information products" of Chinese Mainland.

B.3 Taiwan RoHS compliance

限用物質含有情況標示聲明書 (Declaration of the Presence Condition of the Restricted Substances Marking)

設備名稱: 投影機, 型號(型式): F80 Equipment name: Projector, Type designation: F80						
限用物質及其化學符號 Restricted substances and its chemical symbols						
單元	鉛 Lead	汞 Mercury	鎘 Cadmium	六價鉻 Hexavalent chromium	多溴聯苯	多溴二苯醚



Unit	(Pb)	(Hg)	(Cd)	(Cr6+)	Polybrominated biphenyls (PBB)	Polybrominated diphenyl ethers (PBDE)
印製電路板配件 Printed Circuit Assemblies	—	○	—	○	○	○
外接電(線)纜 External Cables	—	○	○	○	○	○
內部線路 Internal wiring	—	○	○	○	○	○
鏡頭支架 Lensholder	—	○	○	○	○	○
螺帽, 螺釘(栓), 螺旋(釘), 墊圈, 緊固件 Nuts, bolts, screws, washers, Fasteners	—	○	○	○	○	○
激光發生器 Laser	—	○	○	○	○	○
電源供應器 Power Supply Unit	—	○	○	○	○	○
風扇 Fan	—	○	○	○	○	○
遙控器 Remote control	—	○	○	○	○	○
<p>備考1. “超出0.1 wt %” 及 “超出0.01 wt %” 係指限用物質之百分比含量超出百分比含量基準值。 Note 1: “Exceeding 0.1 wt %” and “exceeding 0.01 wt %” indicate that the percentage content of the restricted substance exceeds the reference percentage value of presence condition.</p> <p>備考2. “○” 係指該項限用物質之百分比含量未超出百分比含量基準值。 Note 2: “○” indicates that the percentage content of the restricted substance does not exceed the percentage of reference value of presence.</p> <p>備考3. “—” 係指該項限用物質為排除項目。 Note 3: The “—” indicates that the restricted substance corresponds to the exemption.</p>						

## B.4 Turkey RoHS compliance

### Turkey RoHS compliance



■ Türkiye Cumhuriyeti: AEEE Yönetmeliğine Uygundur.

[Republic of Turkey: In conformity with the WEEE Regulation]

## B.5 Contact information

### Barco contact information

**Registered office address:** President Kennedypark 35, 8500 Kortrijk, Belgium

**Contact address:** Beneluxpark 21, 8500 Kortrijk, Belgium

**Contact address (for Taiwan) :**

Barco Ltd., 33F., No. 16. Xinzhan Rd., Banqiao Dist., New Taipei City 220, Taiwan

## B. Environmental information

---

Tel: +886-2-7715-0099, Fax: +886-2-7715-0097

E-mail: [service.taiwan@barco.com](mailto:service.taiwan@barco.com)

### Importers contact information

To find your local importer, contact Barco directly or one of Barco's regional offices via the contact information given on Barco's web site, [www.barco.com](http://www.barco.com).

### Made in information

The made in country is indicated on the product ID label on the product itself.

### Production date

The month and year of production is indicated on the product ID label on the product itself.

## B.6 Product Info (Taiwan)

---

### Product info



product name 產品名稱:

projector 投影機

model 型號: GPC