



Model: WS for iPad mini4 - Hidden lock - W.grills

Family: WALL-SMART

DWG NO. 10-04-659-SPC

Model No.: 10-01-659

PRODUCT SPEC.

REVISION A  
DATE 25/JAN/2016



### Make Your Wall Smart

#### WS for iPad mini4 - Hidden lock - W.grills - Product description:

The "WS for iPad mini4 - Hidden lock - W.grills" is an adapter for in-wall use of an iPad mini 4 as a control device for Smart home/office/public institutes. The Wall-Smart for iPad mini 4 securely mounts the iPad® mini 4 while allowing easy access, insertion and removal.

#### Key features and benefits:

- Flush with the wall.
- iPad mini 4 mounted horizontally (landscape position).
- The iPad mini 4 home button remains accessible.
- Paintable with the wall paint in any color and texture.
- Wall mount includes audio speaker and mic. grills.
- Easy to operate. Electrically locked/unlocked by positioning of the Wall-Smart key over top right door corner (Wall-Smart key included). After unlocking, door manually opened to insert /remove iPad.
- Standard colors of internal surfaces:
  - back wall and back lid: black;
  - internal surfaces of iPad mini holding tray: white (custom colors available upon request)
  - External surfaces (front panel) are unpainted. To be painted after installation as part of the wall. The adapter is supplied with a paint masking plug.
- iPad mini 4 power supply via standard iPad power cord connected to an external power source through the adapter back lid. (power supply and cord are not included)
- Electric lock power supply (12VDC, 0.28A) via power cord attached. (power supply not included)
- Designed to be installed in 1/2" drywall. Installation of the Wall-Smart adapter is straight-forward. Installation process is similar to drywall construction procedures. Before installation, read Wall-Smart installation instruction 10-04-00101-INS in <http://www.wall-smart.com/faq>
- For installation in concrete/block wall use "WS Concrete Box 406x340" P/N 10-01-013 (sold separately) according installation instruction 10-04-00103-INS in <http://www.wall-smart.com/faq>

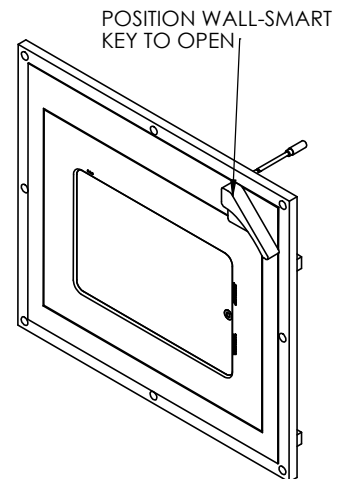

#### Key properties:

- Dimensions (W/H/D): 406mm (16")/ 340mm (13.43")/ 52.1mm (2.05")
- Power Supply: 12VDC, 0.28.
- Weight: 3.1Kg, 6.8pounds.

iPad® is a trademark of Apple Inc., registered in the U.S. and other countries.

