



Model: INVISIBLE MOUNT FOR iPad  
5th gen A1822 & A1823 WG

Model No.: 10-01-737-WG

Family: WALL-SMART

DWG NO. 10-04-737-WG-SPC

PRODUCT SPEC.

REVISION B

DATE 17/JULY/2018



**Make Your Wall Smart**

**“INVISIBLE MOUNT FOR iPad 5th gen A1822 & A1823 WG” - Product description:**

The “INVISIBLE MOUNT FOR iPad 5th gen A1822 & A1823 WG” is an adapter for in-wall flush installation of iPad 5th gen. A1822 & A1823.

The “INVISIBLE MOUNT FOR iPad 5th gen A1822 & A1823 WG” securely mounts the iPad while allowing easy insertion, removal and operation.

**Key features and benefits:**

- Flush with the wall.
- Wall mount may be mounted in any orientation.
- The iPad home button remains accessible.
- The wall mount contains speaker and mic. grills.
- Paintable with the wall paint in any color and texture.
- Allows easy insertion and removal of the iPad.
- The adapter is supplied unpainted (To be painted after installation as part of the wall).
- Designed to be installed in ½” drywall. Installation of the Wall-Smart adapter is straight-forward. Installation process is similar to drywall construction procedures.
- For installation in concrete/block wall use “WS CONCRETE ADAPTOR 350X242” P/N 10-01-530 (sold separately) according installation instruction 10-04-00103-INS in <http://www.wall-smart.com/faq>
- Designed for the use with iPad 5th gen. A1822 & A1823 (by Apple) (iPad is not included).
- Adapter kit contains:
  1. (X1) Wall adapter;
  2. (X2) Wall-Smart rubber pads;
  3. (X1) Wall-Smart Pad Positioning Template

**Key properties:**

- Dimensions: (W/H/D): 346mm (13.6")/ 240.5mm (9")/ 82.7mm (3.26")
- Power Supply: Wall mount includes POE to USB converter.  
The installer should connect the wall mount to an IEEE 802.3af POE power source via CAT5/6 cable and RJ45 connector
- Weight: 1.1Kg, 2.42lbs.
- Material: Moisture resistant MDF
- To be installed in ½” drywall (for installation in 5/8” drywall use 1/8” shim pack P/N 10-01-067 (sold separately)).

iPad® is a trademark of Apple Inc., registered in the U.S. and other countries.

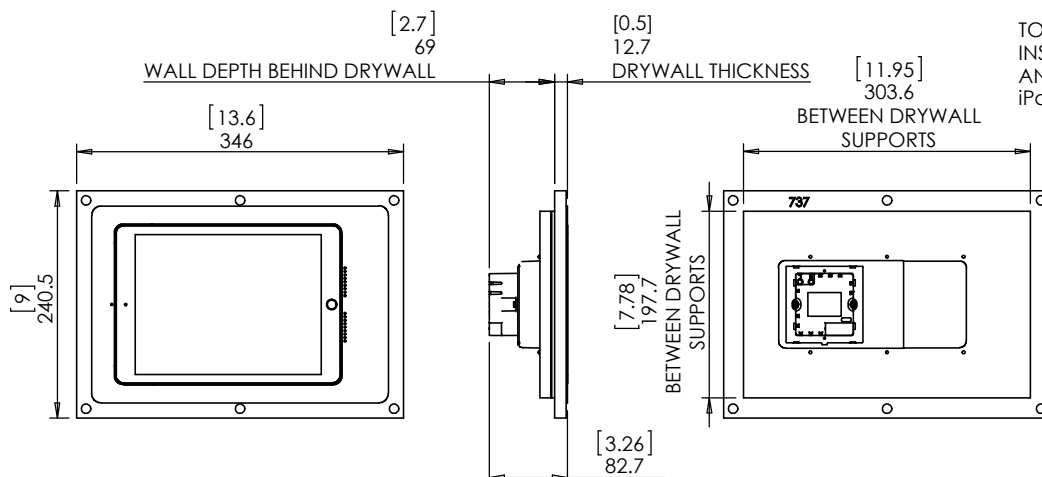
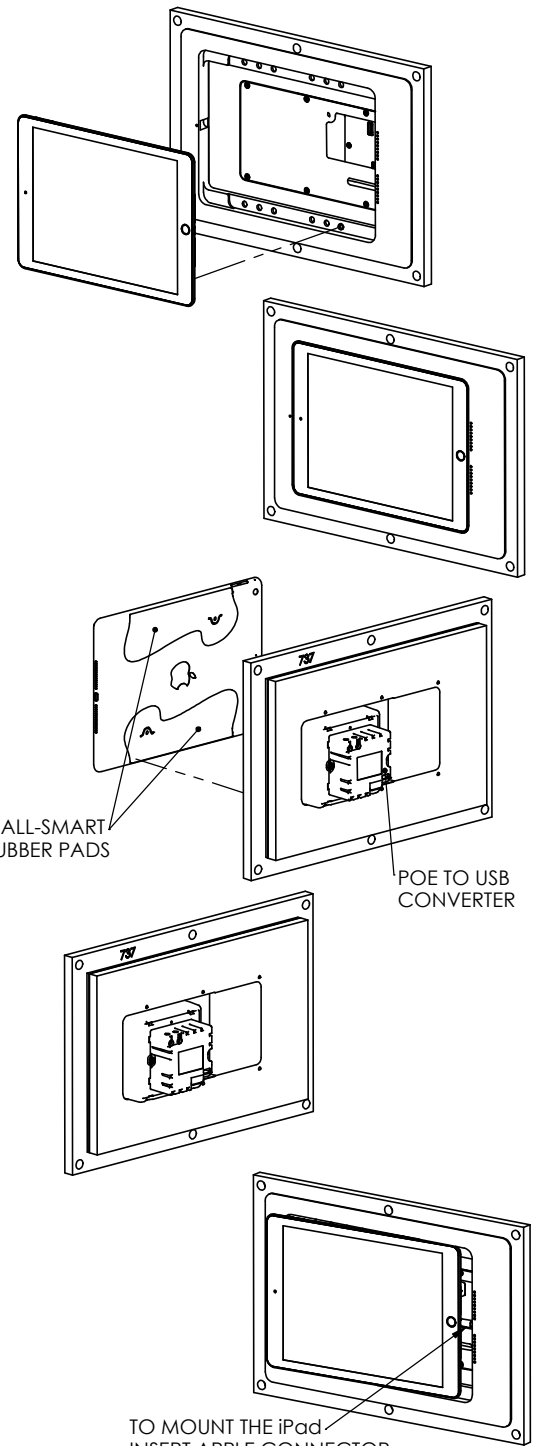

TO MOUNT THE iPad  
INSERT APPLE CONNECTOR  
AND MAGNETICALLY DROP  
iPad IN PLACE.

PUSH TO OPEN



Model: INVISIBLE MOUNT FOR iPad  
5th gen A1822 & A1823 WG

Family: WALL-SMART

DWG NO. 10-04-737-WG-SPC

Model No.: 10-01-737-WG

PRODUCT SPEC.

REVISION B

DATE 17/JULY/2018



### Wall mount installation in drywall:

- Before installing the wall mount, make sure a POE cable is routed to the installation area.
- Preferably, connect POE cable to the wall mount POE to USB converter before installation. See page 4 of this document for details.
- The wall mount is supplied with a protective plug covering the front wall mount opening. Remove plug only after finished painting.
- Perform at least level 4 drywall finish per ASTM C 840.
- In case of level 5 finish (skim coat), mask adaptor opening during skim coat application and sand adaptor front surface until front adaptor edge is visible clean green.
- In case a wall-mount that was designed for 1/2" drywall should be installed in 5/8" drywall, you may use "WS 1/8" Shim pack" P/N 10-01-067 (sold separately).
- Make sure the adaptor is installed on firm supports. A good practice would be to apply construction adhesive between adapter and supports.
- In some cases, it is convenient to use "Telescoping box mounting brackets" (BB2-16T/24T by Cooper Industries plc \ Cooper B-line) or "Telescoping Screw Gun Box Bracket" (TSGB16/24 by ERICO International Corporation) for supports.
- Apply setting-type compound to gaps between adapter and drywall.
- Apply fine premixed drywall joint compound and drywall paper tape (not a mesh tape).
- Avoid applying joint compound to the wall mount front surface. Sand off joint compound covering front wall mount surface.
- Let the setting-type compound and joint compound + paper tapes to dry over night.
- Apply 1st drywall joint compound layer and let dry over night.
- Apply 2nd drywall joint compound layer and let dry over night.
- In some cases as 3rd drywall joint compound layer is required for touch-up.
- Avoid heating installation point by blowers. Let joint compound dry in ambient room temperature.
- Avoid washing the wall during installation. Damp cloth may be used to clean the area.
- Sand adaptor and drywall compound using fine sand paper until front surface of the adaptor is visible clean green.
- Before painting, remove grill protective labels.
- Avoid plugging speaker and mic. grills with paint.
- Avoid spray painting. Do not paint internal surfaces.
- Before inserting the iPad into the wall mount, clean the wall mount internal surfaces of any joint compound or paint.
- Before inserting the iPad, adhere "Wall-Smart rubber pads" to the back of the iPad according to page 3 of this document.

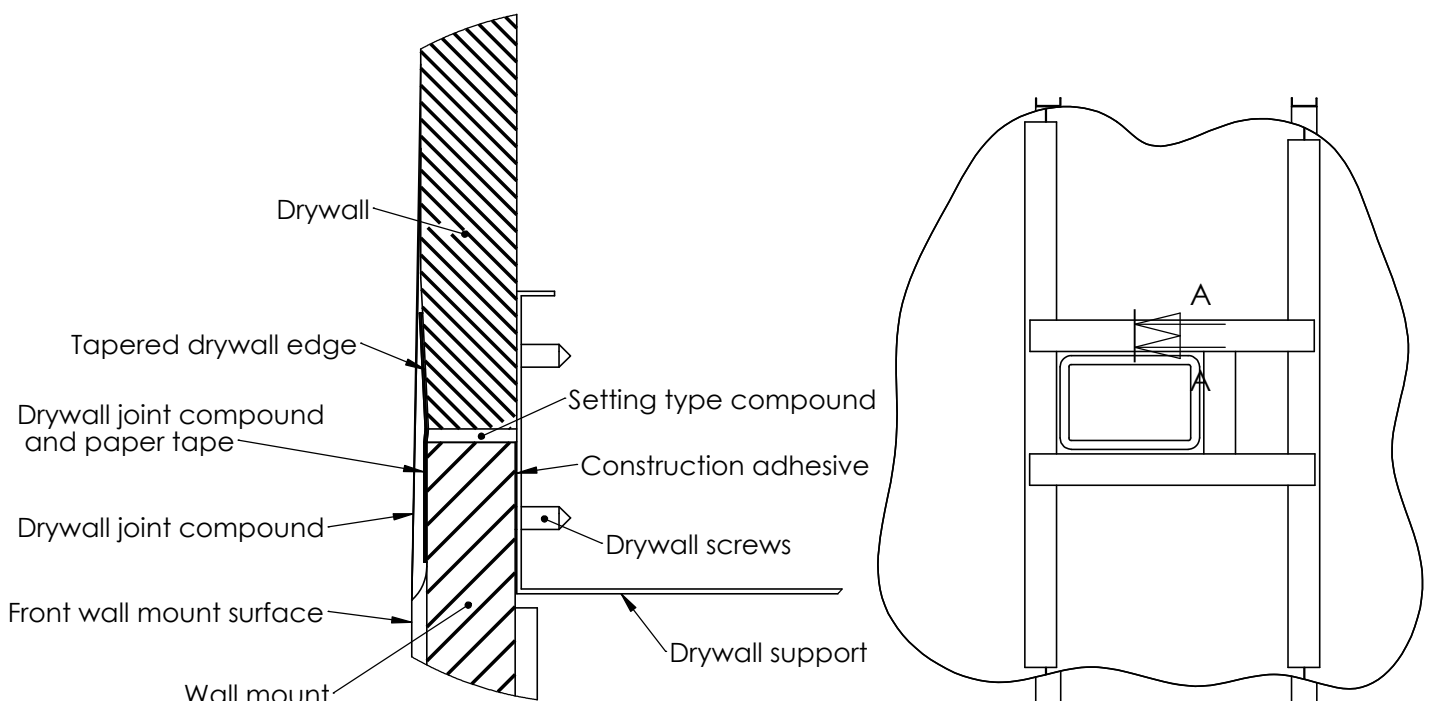



Model: INVISIBLE MOUNT FOR iPad  
5th gen A1822 & A1823 WG

Family: WALL-SMART

DWG NO. 10-04-737-WG-SPC

Model No.: 10-01-737-WG

PRODUCT SPEC.

REVISION B

DATE 17/JULY/2018



### Wall-Smart rubber pads installation:

1. Clean iPads back surface.
2. Position template.

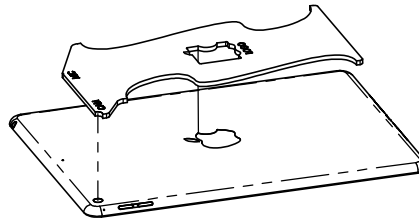

3. Align template cutouts with Apple logo and cam and mic.

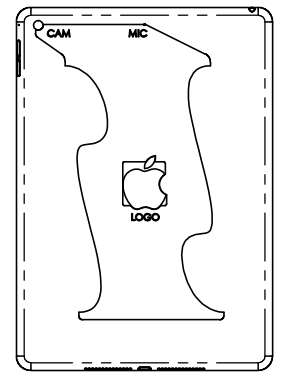

4. Remove protective tape of a rubber pad back adhesive.
5. Align rubber pad to template while maintaining the position of the template.
6. Adhere the rubber pad to the iPad gradually from template to the iPad edge.

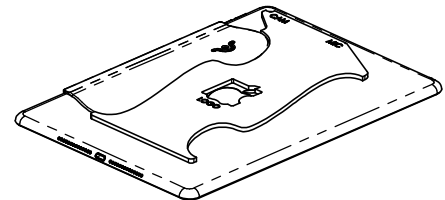

7. Press down from the center of the rubber pad and towards the pad edges to remove air bubbles.
8. Push down the edges of the rubber pad to close all gaps.
9. Repeat steps 4-8 for the second rubber pad.
10. Remove the template and wait 6mins before mounting.

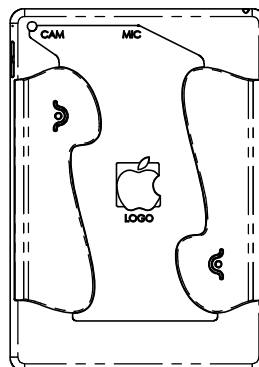
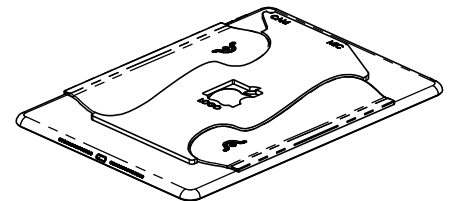



Model: INVISIBLE MOUNT FOR iPad  
5th gen A1822 & A1823 WG

Family: WALL-SMART

DWG NO. 10-04-737-WG-SPC



Model No.: 10-01-737-WG

PRODUCT SPEC.

REVISION B

DATE 17/JULY/2018

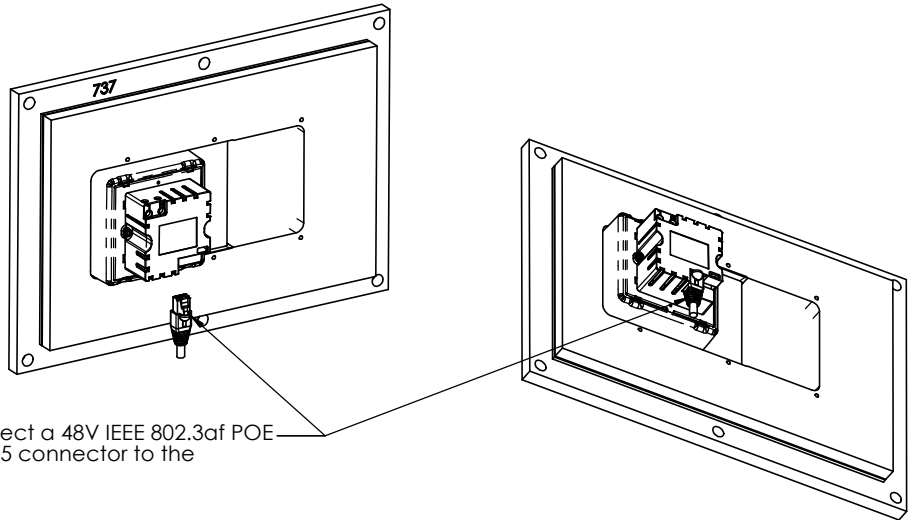

Before installation of the wall mount, connect a 48V IEEE 802.3af POE power source via a CAT5/6 cable and RJ45 connector to the POE to USB converter.

If required, it is possible to unscrew 6 screws, remove the back wall and connect POE cable after the wall mount was installed.

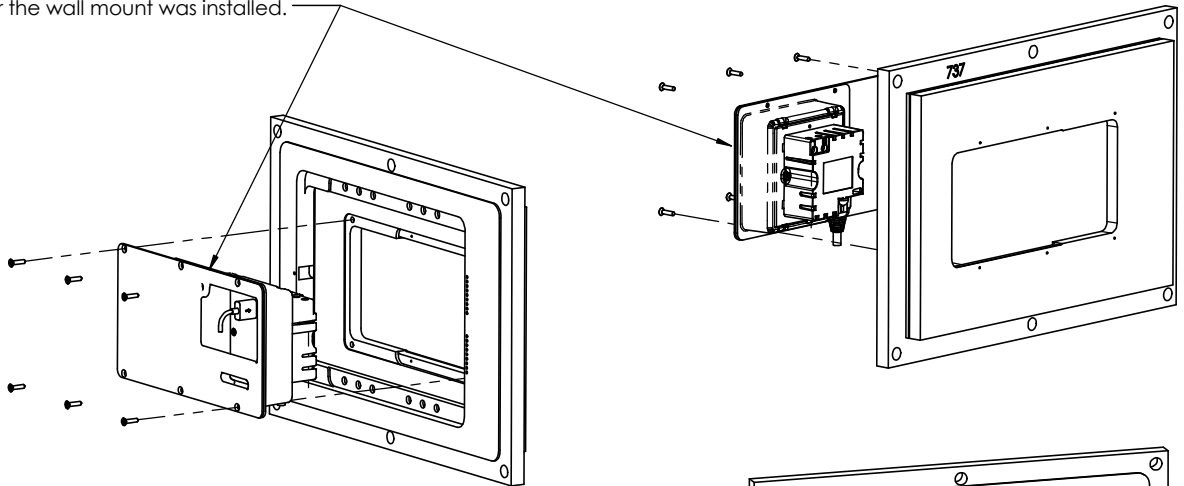

Connect iPad USB cable to POE to USB converter

Organize the cable in the cable tray

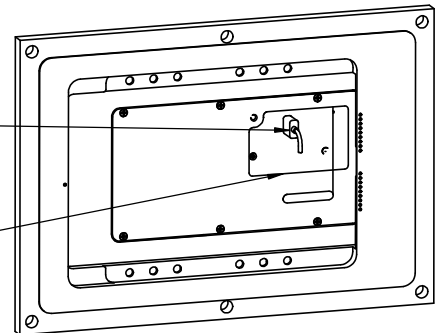

Connect lightning connector to the iPad and insert iPad

