



THE DISPLAY CHOICE
OF PROFESSIONALS™

PN-46 LED-Backlit Display

User Manual

www.agneovo.com

TABLE OF CONTENTS

SAFETY INFORMATION	4
REGULATORY INFORMATION.....	6
CHAPTER 1: UNPACKING AND INSTALLATION.....	12
1.1. Unpacking.....	12
1.2. Package Contents	12
1.3. Installation Notes	12
1.4. Installing and Removing Table Stands (optional).....	13
1.4.1. To install table stands:	13
1.4.2. To remove table stands:	13
1.5. Mounting on a Wall	13
1.5.1. Ventilation Requirements for enclosure locating	14
CHAPTER 2: PARTS AND FUNCTIONS	15
2.1. Control Panel.....	15
2.2. Input/Output Terminals.....	16
2.3. Remote Control.....	17
2.3.1 General functions	17
2.3.2 Inserting the batteries in the remote control	19
2.3.3 Handling the remote control	19
2.3.4 Operating range of the remote control.....	19
CHAPTER 3: CONNECTING EXTERNAL EQUIPMENT	20
3.1 Using the Switch Cover	20
3.2 Connecting External Equipment (DVD/VCR/VCD).....	20
3.2.1 Using COMPONENT video input.....	20
3.2.2 Using HDMI video input.....	21
3.3 Connecting a PC.....	21
3.3.1 Using VGA input	21
3.3.2 Using DVI input.....	22
3.3.3 Using HDMI input.....	22
3.4 External Audio Connection	23
3.4.1 Connecting external speakers	23
3.4.2 Connecting an external audio device	23
3.5 Connecting Multiple Displays in a Daisy-chain Configuration.....	24
3.5.1 Video connection	24
3.5.2 Audio connection	24
CHAPTER 4: OSD MENU.....	25
4.1 Navigating the OSD Menu	25
4.1.1 Navigating the OSD menu using the remote control	25
4.1.2 Navigating the OSD menu using the display's control buttons.....	25
4.2 OSD Menu Overview	26
4.2.1 PICTURE menu.....	26
4.2.2 SCREEN menu.....	27

TABLE OF CONTENTS

4.2.3	AUDIO menu	30
4.2.4	PIP menu	30
4.2.5	CONFIGURATION1 menu	32
4.2.6	CONFIGURATION2 menu	34
4.2.7	CONFIGURATION3 menu	37
4.2.8	ADVANCED OPTION menu	38
CHAPTER 5: INPUT MODE	41
5.1	VGA Resolution:	41
5.2	SDTV Resolution:	41
5.3	HDTV Resolution:	41
CHAPTER 6: CLEANING AND TROUBLESHOOTING	43
6.1	Cleaning.....	43
6.2	Troubleshooting	44
CHAPTER 7: TECHNICAL SPECIFICATIONS	46

SAFETY INFORMATION

Warnings and Precautions

KNOW THESE SAFETY SYMBOLS



CAUTION: TO REDUCE THE RISK OF ELECTRIC SHOCK, DO NOT REMOVE COVER (OR BACK). NO USER SERVICEABLE PARTS INSIDE. REFER SERVICING TO QUALIFIED SERVICE PERSONNEL.



This symbol indicates high voltage is present inside. It is dangerous to make any kind of contact with any inside part of this product.



This symbol alerts you that important literature concerning operation and maintenance has been included with this product.

Note to CATV system installer: This reminder is provided to call CATV system installer's attention to Article 820-40 of the National Electrical Code (Section 54 of Canadian Electrical Code, Part I), that provides guidelines for proper grounding and, in particular, specifies that the cable ground shall be connected to the grounding system of the building as close to the point of cable entry as practical.

CAUTION: FCC/CSA regulations state that any unauthorized changes or modifications to this equipment may void the user's authority to operate it.

CAUTION: To prevent electric shock, match the wide blade of plug to the wide slot, and fully insert the plug.

IMPORTANT: One Federal Court has held that unauthorized recording of copyrighted TV programs is an infringement of U.S. copyright laws. Certain Canadian programs may also be copyrighted and any unauthorized recording in whole or in part may be in violation of these rights.

TO PREVENT DAMAGE WHICH MAY RESULT IN FIRE OR ELECTRIC SHOCK HAZARD, DO NOT EXPOSE THIS APPLIANCE TO RAIN OR MOISTURE.

The Socket-outlet shall be installed near the apparatus and shall be easily accessible.

SAFETY INFORMATION

Read and follow these instructions when connecting and using your Public Information Display:



- Unplug the display if you are not going to use it for an extensive period of time.
- Unplug the display if you need to clean it with a slightly damp cloth. The screen may be wiped with a dry cloth when the power is off. However, never use alcohol, solvents or ammonia-based liquids.
- Consult a service technician if the display does not operate normally when you have followed the instructions in this manual.
- The casing cover should be opened only by qualified service personnel.
- Keep the display out of direct sunlight and away from stoves or any other heat source.
- Remove any object that could fall into the vents or prevent proper cooling of the display's electronics.
- Do not block the ventilation holes on the cabinet.
- Keep the display dry. To avoid electric shock, do not expose it to rain or excessive moisture.
- If turning off the display by detaching power cable or DC power cord, wait for 6 seconds before attach the power cable or DC power cord for normal operation.
- To avoid the risk of shock or permanent damage to the set do not expose the display to rain or excessive moisture.
- When positioning the display, make sure the power plug and outlet are easily accessible.
- **IMPORTANT:** Always activate Anti-Burn-in during your application. If a still image in high contrast remains on the screen for an extended period of time, it may leave an 'after-image' or 'ghost image' on the front of the screen. This is a well-known phenomenon that is caused by the shortcomings inherent in the LCD technology. In most cases the afterimage will disappear gradually over a period of time after the power has been switched off. Be aware that the after-image symptom cannot be repaired and is not covered under warranty.

REGULATORY INFORMATION

CE Declaration of Conformity

We declare under our responsibility that the product is in conformity with the following standards:

- EN60950-1:2006 (Safety requirement of Information Technology Equipment)
- EN55022:2006+A1:2007 (Radio Disturbance requirement of Information Technology Equipment)
- EN55024:1998+A1:2001+A2:2003 (Immunity requirement of Information Technology Equipment)
- EN61000-3-2:2006 (Limits for Harmonic Current Emission)
- EN61000-3-3:2008 (Limitation of Voltage Fluctuation and Flicker) following provisions of directives applicable
- 2006/95/EC (Low Voltage Directive)
- 2004/108/EC (EMC Directive)
- 2005/32/EC (ErP, Energy-related Product Directive) EC No. 642/2009 Implementing
- 93/68/EEC (Amendment of EMC and Low Voltage Directive) and is produced by a manufacturing organization on ISO9000 level.

Federal Communications Commission (FCC) Notice (U.S. Only)



This equipment has been tested and found to comply with the limits for a Class B digital device, pursuant to Part 15 of the FCC Rules. These limits are designed to provide reasonable protection against harmful interference when the equipment is operated in a commercial environment. This equipment generates, uses and can radiate radio frequency energy and, if not installed and used in accordance with the instructions manual, may cause harmful interference to radio communications. Operation of this equipment in a residential area is likely to cause harmful interference in which case the user will be required to correct the interference at his own expense.



Changes or modifications not expressly approved by the party responsible for compliance could void the user's authority to operate the equipment.

Use only RF shielded cable that was supplied with the display when connecting this display to a computer device.

To prevent damage which may result in fire or shock hazard, do not expose this appliance to rain or excessive moisture.

THIS CLASS B DIGITAL APPARATUS MEETS ALL REQUIREMENTS OF THE CANADIAN INTERFERENCE- CAUSING EQUIPMENT REGULATIONS.



This device complies with Part 15 of the FCC Rules. Operation is subject to the following two conditions: (1) this device may not cause harmful interference, and (2) this device must accept any interference received, including interference that may cause undesired operation.

REGULATORY INFORMATION

Polish Center for Testing and Certification Notice

The equipment should draw power from a socket with an attached protection circuit (a three-prong socket). All equipment that works together (computer, monitor, printer, and so on) should have the same power supply source.

The phasing conductor of the room's electrical installation should have a reserve short-circuit protection device in the form of a fuse with a nominal value no larger than 16 amperes (A).

To completely switch off the equipment, the power supply cable must be removed from the power supply socket, which should be located near the equipment and easily accessible.

A protection mark "B" confirms that the equipment is in compliance with the protection usage requirements of standards PN-93/T-42107 and PN-89/E-06251.

Wymagania Polskiego Centrum Badań i Certyfikacji

Urządzenie powinno być zasilane z gniazda z przyłączonym obwodem ochronnym (gniazdo z kołkiem). Współpracujące ze sobą urządzenia (komputer, monitor, drukarka) powinny być zasilane z tego samego źródła.

Instalacja elektryczna pomieszczenia powinna zawierać w przewodzie fazowym rezerwową ochronę przed zwarciami, w postaci bezpiecznika o wartości znamionowej nie większej niż 16A (amperów).

W celu całkowitego wyłączenia urządzenia z sieci zasilania, należy wyjąć wtyczkę kabla zasilającego z gniazda, które powinno znajdować się w pobliżu urządzenia i być łatwo dostępne.

Znak bezpieczeństwa "B" potwierdza zgodność urządzenia z wymaganiami bezpieczeństwa użytkowania zawartymi w PN-93/T-42107 i PN-89/E-06251.

Pozostałe instrukcje bezpieczeństwa

- Nie należy używać wtyczek adapterowych lub usuwać kołka obwodu ochronnego z wtyczki. Jeżeli konieczne jest użycie przedłużacza to należy użyć przedłużacza 3-żyłowego z prawidłowo połączonym przewodem ochronnym.
- System komputerowy należy zabezpieczyć przed nagłymi, chwilowymi wzrostami lub spadkami napięcia, używając eliminatora przepięć, urządzenia dopasowującego lub bezzakłóceniewego źródła zasilania.
- Należy upewnić się, aby nic nie leżało na kablach systemu komputerowego, oraz aby kable nie były umieszczone w miejscu, gdzie można byłoby na nie nadeptywać lub potykać się o nie.
- Nie należy rozlewać napojów ani innych płynów na system komputerowy.
- Nie należy wpychać żadnych przedmiotów do otworów systemu komputerowego, gdyż może to spowodować pożar lub porażenie prądem, poprzez zwarcie elementów wewnętrznych.
- System komputerowy powinien znajdować się z dala od grzejników i źródeł ciepła. Ponadto, nie należy blokować otworów wentylacyjnych. Należy unikać kładzenia luźnych papierów pod komputer oraz umieszczania komputera w ciasnym miejscu bez możliwości cyrkulacji powietrza wokół niego.

Electric, Magnetic and Electromagnetic Fields ("EMF")

1. We manufacture and sell many products targeted at consumers, which, like any electronic apparatus, in general have the ability to emit and receive electromagnetic signals.
2. One of our leading Business Principles is to take all necessary health and safety measures for our products, to comply with all applicable legal requirements and to stay well within the EMF standards applicable at the time of producing the products.
3. We are committed to develop, produce and market products that cause no adverse health effects.
4. We confirm that if its products are handled properly for their intended use, they are safe to use according to scientific evidence available today.
5. We play an active role in the development of international EMF and safety standards, enabling us to anticipate further developments in standardization for early integration in its products.

REGULATORY INFORMATION

Information for U.K. only

WARNING - THIS APPLIANCE MUST BE EARTHED.

IMPORTANT: This apparatus is supplied with an approved moulded 13A plug. To change a fuse in this type of plug proceed as follows:

1. Remove fuse cover and fuse.
2. Fit new fuse which should be a BS 1362 5A, A.S.T.A. or BSI approved type.
3. Refit the fuse cover.

If the fitted plug is not suitable for your socket outlets, it should be cut off and an appropriate 3-pin plug fitted in its place.

If the mains plug contains a fuse, this should have a value of 5A. If a plug without a fuse is used, the fuse at the distribution board should not be greater than 5A.

⚠ NOTE: The severed plug must be destroyed to avoid a possible shock hazard should it be inserted into a 13A socket elsewhere.

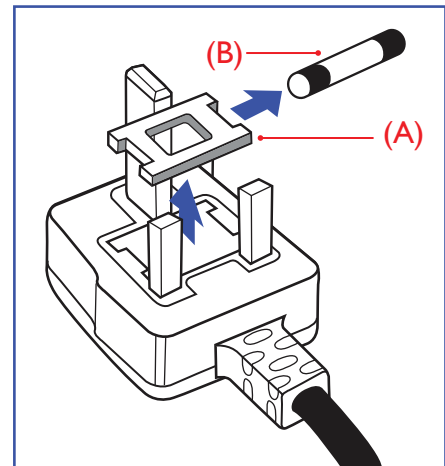

How to connect a plug:

The wires in the mains lead are coloured in accordance with the following code:

- BLUE - "NEUTRAL" ("N")
- BROWN - "LIVE" ("L")
- GREEN & YELLOW - "EARTH" ("E")

1. The GREEN & YELLOW wire must be connected to the terminal in the plug which is marked with the letter "E" or by the Earth symbol or coloured GREEN or GREEN & YELLOW.
2. The BLUE wire must be connected to the terminal which is marked with the letter "N" or coloured BLACK.
3. The BROWN wire must be connected to the terminal which marked with the letter "L" or coloured RED.

Before replacing the plug cover, make certain that the cord grip is clamped over the sheath of the lead - not simply over the three wires.

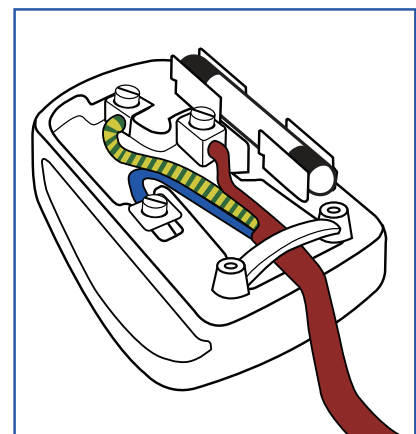

REGULATORY INFORMATION

China RoHS

中国电子信息产品污染控制标识要求 (中国RoHS法规标示要求) 产品中有毒有害物质或元素的名称及含量

部件名称	有毒有害物质或元素					
	铅 (Pb)	汞 (Hg)	镉 (Cd)	六价铬 (Cr 6+)	多溴联苯 (PBB)	多溴二苯醚 (PBDE)
外壳	O	O	O	O	O	O
液晶面板	X	X	O	O	O	O
电路板组件	X	O	O	O	O	O
附件 (遥控器, 电源线, 连接线)	X	O	O	O	O	O
遥控器电池	X	O	O	O	O	O

O: 表示该有毒有害物质在该部件所有均质材料中的含量均在 SJ/T11363-2006 标准规定的限量要求以下。

X: 表示该有毒有害物质至少在该部件的某一均质材料中的含量超出 SJ/T11363-2006 标准规定的限量要求。



环保使用期限

此标识指期限(十年), 电子信息产品中含有的有毒有害物质或元素在正常使用的条件下不会发生外泄或突变, 电子信息产品用户使用该电子信息产品不会对环境造成严重污染或对其人身、财产造成严重损害的期限。

REGULATORY INFORMATION

North Europe (Nordic Countries) Information

Placering/Ventilation

WARNING: FÖRSÄKRA DIG OM ATT HUVUDBRYTARE OCH UTTAG ÄR LÄTÅTKOMLIGA, NÄR DU STÄLLER DIN UTRUSTNING PÅPLATS.

Placering/Ventilation

ADVARSEL: SØRG VED PLACERINGEN FOR, AT NETLEDNINGENS STIK OG STIKKONTAKT ER NEMT TILGÆNGELIGE.

Paikka/Ilmankierto

VAROITUS: SIJOITA LAITE SITEN, ETTÄ VERKKOJOHTO VOIDAAN TARVITTAESSA HELPOSTI IRROTTAA PISTORASIESTA.

Plassering/Ventilasjon

ADVARSEL: NÅR DETTE UTSTYRET PLASSERES, MÅ DU PASSE PÅ AT KONTAKTENE FOR STØMTILFØRSEL ER LETTE Å NÅ.

End-of-Life Disposal

Your new Public Information Display contains materials that can be recycled and reused. Specialized companies can recycle your product to increase the amount of reusable materials and to minimize the amount to be disposed of.

Please find out about the local regulations on how to dispose of your old display from your local dealer.

Waste Electrical and Electronic Equipment-WEEE

Attention users in European Union private households



This marking on the product or on its packaging illustrates that, under European Directive 2002/96/EG governing used electrical and electronic appliances, this product may not be disposed of with normal household waste. You are responsible for disposal of this equipment through a designated waste electrical and electronic equipment collection. To determine the locations for dropping off such waste electrical and electronic, contact your local government office, the waste disposal organization that serves your household or the store at which you purchased the product.

REGULATORY INFORMATION

Attention users in United States:

Like all LCD products, this set contains a lamp with Mercury. Please dispose of according to all Local, State and Federal Laws. For the disposal or recycling information, contact: www.mygreenelectronics.com or www.eiae.org.

End of Life Directives-Recycling



Your new Public Information Display contains several materials that can be recycled for new users.

Like all LCD products, this set contains a lamp with Mercury. Please dispose of according to all Local, State, and Federal laws.

CHAPTER 1: UNPACKING AND INSTALLATION

1.1. Unpacking

- This product is packed in a carton, together with the standard accessories.
- Any other optional accessories will be packed separately.
- Due to the size and weight of this display it is recommended for two people to move it.
- After opening the carton, ensure that the content is in good condition and complete.

1.2. Package Contents

Please verify that you received the following items with your package content:

- CD ROM
- Remote control with AAA batteries
- Power cord (1.8 m)
- VGA cable (1.8 m)
- Power switch cover
- Screw for Power switch cover (M3x8)
- Cable ties

* The supplied power cord varies depending on destination.



For EU



For China



CD ROM

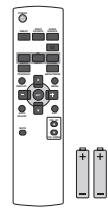

Remote Control and AAA Batteries



For North America



For UK



Power switch cover



Screw for Power switch cover (M3 x 8) x 1



Video Signal Cable (D-SUB to D-SUB Cable)



Cable ties

▲ NOTES:

- Please make sure that for all other regions, apply a power cord that conforms to the AC voltage of the power socket and has been approved by and complies with the safety regulations of the particular country.
- You might like to save the package box and packing material for shipping the display.

1.3. Installation Notes

- Due to the high power consumption, always use the plug exclusively designed for this product. If an extended line is required, please consult your service agent.
- The product should be installed on a flat surface to avoid tipping. The distance between the back of the product and the wall should be maintained for proper ventilation. Avoid installing the product in the kitchen, bathroom or any other places with high humidity so as not to shorten the service life of the electronic components.
- The product can normally operate only under 3000m in altitude. In installations at altitudes above 3000m, some abnormalities may be experienced.

UNPACKING AND INSTALLATION

1.4. Installing and Removing Table Stands (optional)

1.4.1. To install table stands:

1. Power off the display.
2. Spread a protective sheet on a flat surface.
3. Grab the carrying handles and place the display face-down on the protective sheet.
4. After inserting the stand in the guide block, tighten the screws on both sides of the display.

▲ NOTE: The long-end side of the stand should face to the front while installing.

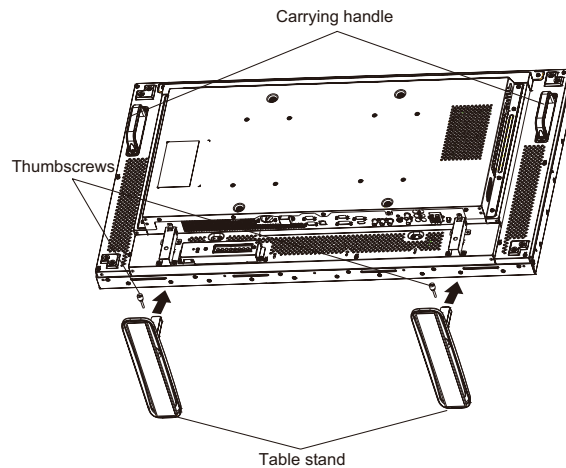

1.4.2. To remove table stands:

1. Power off the display.
2. Spread a protective sheet on a flat surface.
3. Grab the carrying handles and place the display face-down on the protective sheet.
4. Remove screws using a screwdriver and place them in a safe place for reuse.

1.5. Mounting on a Wall

To mount this display to a wall, you will have to obtain a standard wall-mounting kit (commercially available). We recommend using a mounting interface that complies with TUV-GS and/or UL1678 standard in North America.

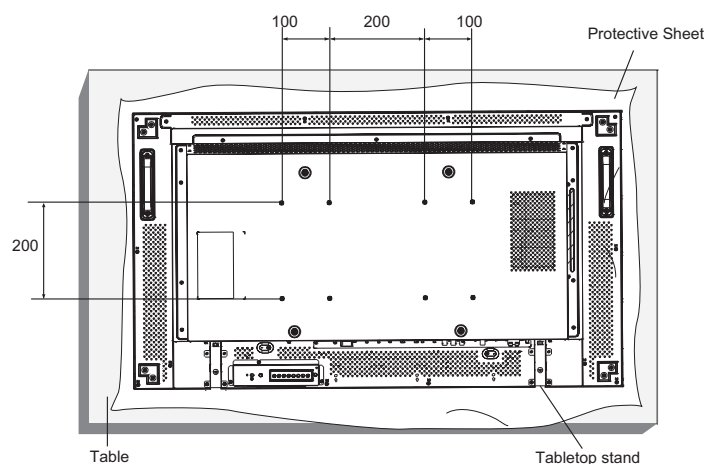

UNPACKING AND INSTALLATION

1. Lay a protective sheet on a table, which was wrapped around the display when it was packaged, beneath the screen surface so as not to scratch the screen face.
2. Ensure you have all accessories for mounting this display (wall mount, ceiling mount, table stand, etc).
3. Follow the instructions that come with the base mounting kit. Failure to follow correct mounting procedures could result in damage to the equipment or injury to the user or installer. Product warranty does not cover damage caused by improper installation.
4. For the wall-mounting kit, use M6 mounting screws (having a length 10 mm longer than the thickness of the mounting bracket) and tighten them securely.

Caution:

To prevent the display from falling:

- For wall or ceiling installation, we recommend installing the display with metal brackets which are commercially available. For detailed installation instructions, refer to the guide received with the respective bracket.
- To lessen the probability of injury and damage resulting from fall of the display in case of earthquake or other natural disaster, be sure to consult the bracket manufacturer for installation location.

1.5.1. Ventilation Requirements for enclosure locating

To allow heat to disperse, leave space between surrounding objects as shown in the diagram below.

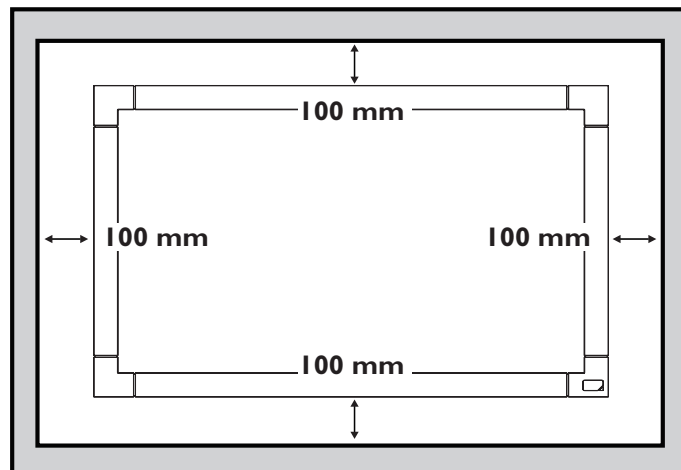

CHAPTER 2: PARTS AND FUNCTIONS

2.1. Control Panel

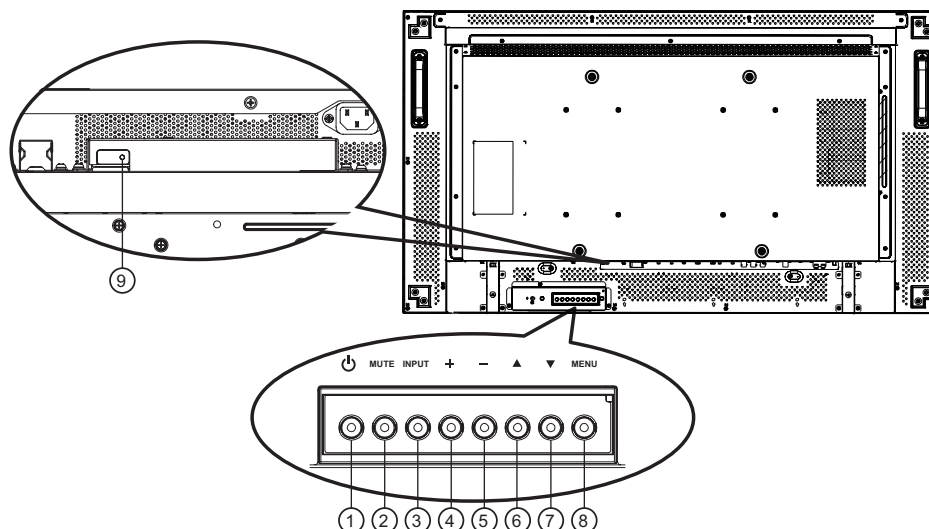

① POWER button

Use this button to turn the display on or put the display to standby.

② MUTE button

Switch the audio mute ON/OFF.

③ INPUT button

- Use this button to select the input source.
- When the On Screen Display menu is active, this is also used as the [SET] button.

④ [+] button

Increase the adjustment while OSD menu is on, or increase the audio output level while OSD menu is off.

⑤ [-] button

Decrease the adjustment while OSD menu is on, or decrease the audio output level while OSD menu is off.

⑥ [▲] button

Move the highlight bar up to adjust the selected item while OSD menu is on.

⑦ [▼] button

Move the highlight bar down to adjust the selected item while OSD menu is on.

⑧ MENU button

Return to previous menu while OSD menu is on, or to activate the OSD menu when OSD menu is off.

▲ NOTE: "Keyboard Control Lock Mode"

This function completely disables the access to all Keyboard Control functions. To enable or disable the keyboard control lock, press both [▲] and [▼] buttons and hold down continuously for more than 3 (three) seconds.

⑨ Remote control sensor and power status indicator

- Receives command signals from the remote control.
- Indicates the operating status of the display:
 - Lights green when the display is turned on
 - Lights red when the display is in standby mode
 - Lights amber when the display enters APM mode
 - When {SCHEDULE} is enabled, the light blinks green and red
 - If the light blinks red, it indicates that a failure has been detected
 - Off when the main power of the display is turned off

PARTS AND FUNCTIONS

2.2. Input/Output Terminals

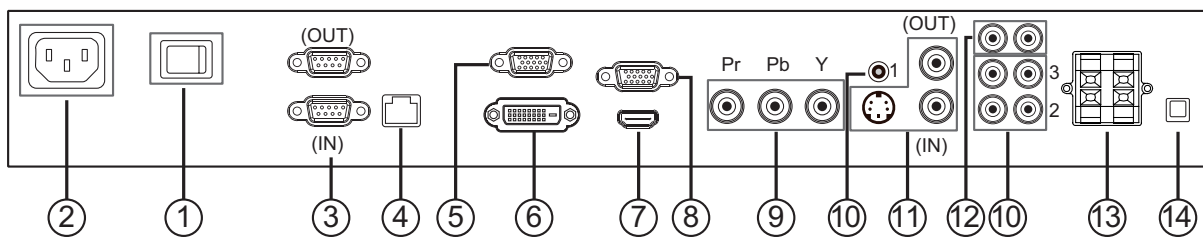
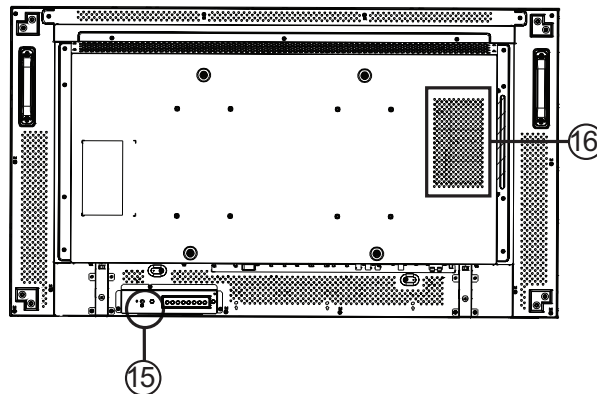

- ① **MAIN POWER SWITCH**
Press to switch the main power on/off.
- ② **AC IN**
Connect the supplied power cord to the wall outlet.
- ③ **RS232C (OUT/IN)**
RS232C network input/output connection for the use of loop-through function.
- ④ **RJ-45**
LAN control function for the use of remote control signal from control center.
- ⑤ **VGA OUT (D-Sub)**
Output the VGA signal from the VGA IN (D-Sub).
- ⑥ **DVI-D IN**
Connect the DVI-D output of a PC, or the HDMI output of an AV device by using a DVI-HDMI cable.
- ⑦ **HDMI IN**
Connect the HDMI output of an AV device, or the DVI-D output of a PC by using a DVI-HDMI cable.
- ⑧ **VGA IN (D-Sub)**
Connect the computer VGA output.
- ⑨ **COMPONENT IN (BNC)**
Connect the component YPbPr output from external AV device.
- ⑩ **AUDIO IN 1, 2, 3**
Connect audio input from external AV device.
 - **AUDIO IN 1:** 3.5mm stereo phone jack
 - **AUDIO IN 2, 3:** RCA phone jack
- ⑪ **VIDEO IN/OUT**
 - **S-VIDEO IN (Mini DIN 4 pin):** Connect the S-VIDEO (Y/C separate signal) input.
 - **VIDEO IN (BNC):** Connect the composite video signal input.
 - **VIDEO OUT (BNC):** Connect the composite video signal output from VIDEO IN (BNC).
- ⑫ **AUDIO OUT R/L (RCA)**
Connect the audio signal output from AUDIO IN 1, 2, or 3 jack to an external AV device.
- ⑬ **SPEAKERS OUT R/L**
Connect the audio output to external speakers.
- ⑭ **SPEAKER SWITCH**
Press to switch the internal speaker on/off.
- ⑮ **KENSINGTON LOCK**
For security and theft prevention.
- ⑯ **OPS SLOT**
Designed to simplify the changing, maintenance, and upgrading of a OPS PC module or a OPS media player.

PARTS AND FUNCTIONS

2.3. Remote Control

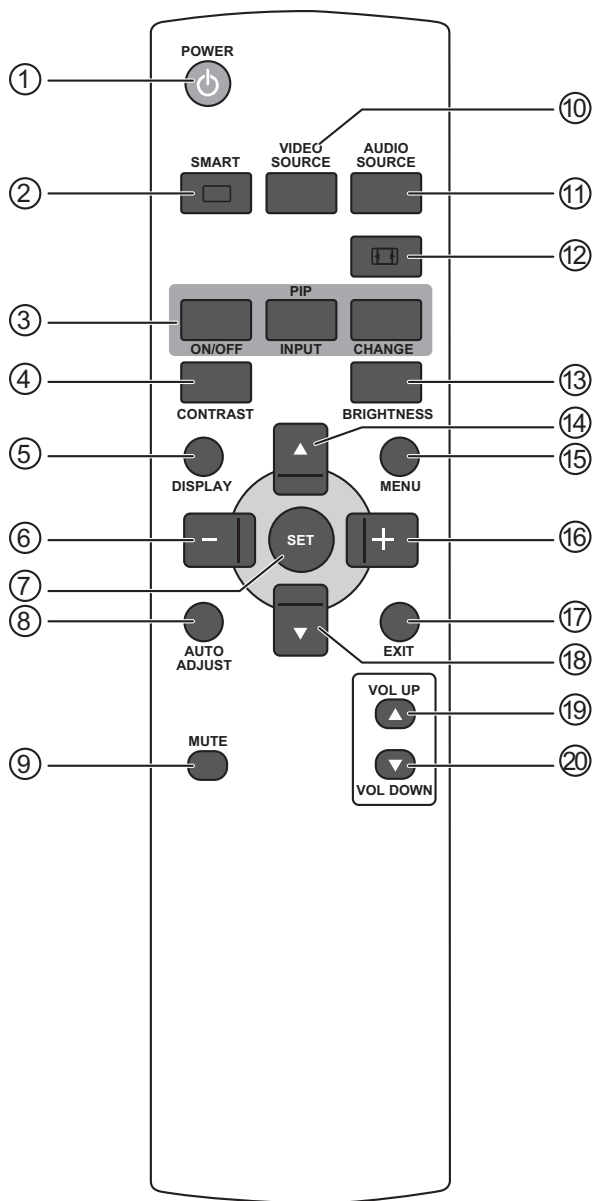

2.3.1 General functions

- ① **[POWER] button**
Press to switch on the display from standby mode. Press again to turn it off and back into standby mode.
- ② **[SMART] button**
Press to activate Smart Menu. Press [▲] or [▼] button to select menu options. Press [SET] button to confirm and exit the selection.
 - **Standard:** Used for normal images (factory setting)

- **Highbright:** Used for moving image such as Video
 - **sRGB:** Used for text based images
- ③ **[PIP] (Picture In Picture) button**
[ON/OFF]: Turn PIP mode ON/OFF.
[INPUT]: Select the input signal for the sub-picture.
[CHANGE]: Toggle between the main picture and sub picture.
 - ④ **[CONTRAST] button**
Press to activate Contrast Menu. Press [+] or [-] button to adjust the value. Press [MENU] button to confirm and exit.
 - ⑤ **[DISPLAY] button**
Press to turn on/off the information OSD displayed on the upper right corner of the screen.
 - ⑥ **[-] button**
 - Press to move the selection left in OSD menu.
 - Press to decrease the value in OSD menu.
 - Press to move the sub-picture left in PIP mode.
 - ⑦ **[SET] button**
Press to activate the setting inside the OSD menu.
 - ⑧ **[AUTO ADJUST] button**
Press to run the Auto Adjust function.
▲ NOTE: This button is functional for **VGA** input only.
 - ⑨ **[MUTE] button**
Press to turn the mute function on/off.
 - ⑩ **[VIDEO SOURCE] button**
Press to toggle Video Source Menu. Press [▲] or [▼] button to select one of the video sources among **HDMI**, **DVI-D**, **VGA**, **DVD / HD**, **VIDEO-S**, or **VIDEO** . Press [SET] button to confirm and exit.
 - ⑪ **[AUDIO SOURCE] button**
Press to toggle Audio Source Menu. Press [▲] or [▼] button to select one of the audio sources among **HDMI**, **AUDIO1**, **AUDIO2**, or **AUDIO3**. Press [SET] button to confirm and exit.
 - ⑫ **Picture Format button** [Aspect Ratio Icon]
Press to switch screen aspect ratio.
 - For PC signal: **FULL**, **NORMAL**, **CUSTOM** and **REAL**.

PARTS AND FUNCTIONS

- For Video signal: **FULL, NORMAL, DYNAMIC, CUSTOM** and **REAL**.

⑬ **[BRIGHTNESS] button**

Press to toggle Brightness Menu. Press [+] or [-] button to adjust the value. Press [MENU] button to confirm and exit.

⑭ **[▲] button**

- Press to move the selection up in OSD menu.
- Press to move the sub-picture up in PIP mode.

⑮ **[MENU] button**

Press to turn the OSD menu on/off.

⑯ **[+] button**

- Press to move the selection right in OSD menu.
- Press to increase the value in OSD menu.
- Press to move the sub-picture right in PIP mode.

⑰ **[EXIT] button**

Press to turn back to the previous OSD menu.

⑱ **[▼] button**

- Press to move the selection down in OSD menu.
- Press to move the sub-picture down in PIP mode.

⑲ **[VOL UP] button**

Press to increase the audio output level.

⑳ **[VOL DOWN] button**

Press to decrease the audio output level.

PARTS AND FUNCTIONS

2.3.2 Inserting the batteries in the remote control

The remote control is powered by two 1.5V AAA batteries.

To install or replace batteries:

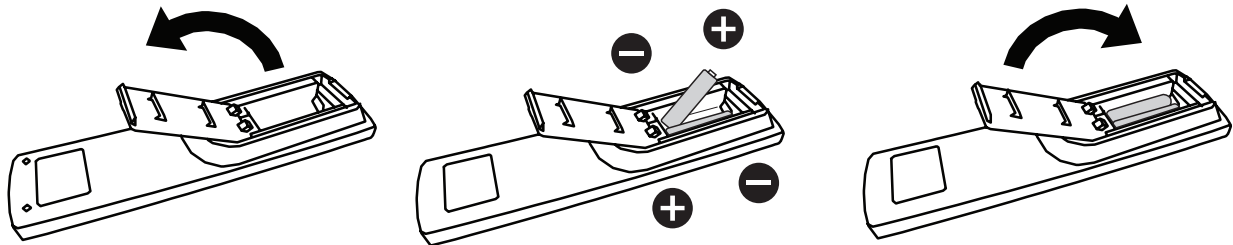

1. Press and then slide the cover to open it.
2. Align the batteries according to the (+) and (-) indications inside the battery compartment.
3. Replace the cover.

⚠ Caution:

The incorrect use of batteries can result in leaks or bursting. Be sure to follow these instructions:

- Place “AAA” batteries matching the (+) and (-) signs on each battery to the (+) and (-) signs of the battery compartment.
- Do not mix battery types.
- Do not combine new batteries with used ones. It causes shorter life or leakage of batteries.
- Remove the dead batteries immediately to prevent them from liquid leaking in the battery compartment. Don't touch exposed battery acid, it cause damage to your skin.

⚠ **NOTE:** If you do not intend to use the remote control for a long period, remove the batteries.

2.3.3 Handling the remote control

- Do not subject to strong shock.
- Do not allow water or other liquid to splash the remote control. If the remote control gets wet, wipe it dry immediately.
- Avoid exposure to heat and steam.
- Other than to install the batteries, do not open the remote control.

2.3.4 Operating range of the remote control

Point the top of the remote control toward the display's remote control sensor when pressing a button.

- Environment: under 200-400 cd/m²
- RC sensor for PN-46 only use in 30cm. (sensor behind in panel)

⚠ **NOTE:** The remote control may not function properly when the remote control sensor on the display is under direct sunlight or strong illumination, or when there is an obstacle in the path of signal transmission.

CHAPTER 3: CONNECTING EXTERNAL EQUIPMENT

3.1 Using the Switch Cover

A cover for the power switch is provided to prevent the display from being turned on or off accidentally.

To lock the cover into position:

1. Align and insert the cover to the indentation located beside the main switch.
2. Use the screw to lock the cover.

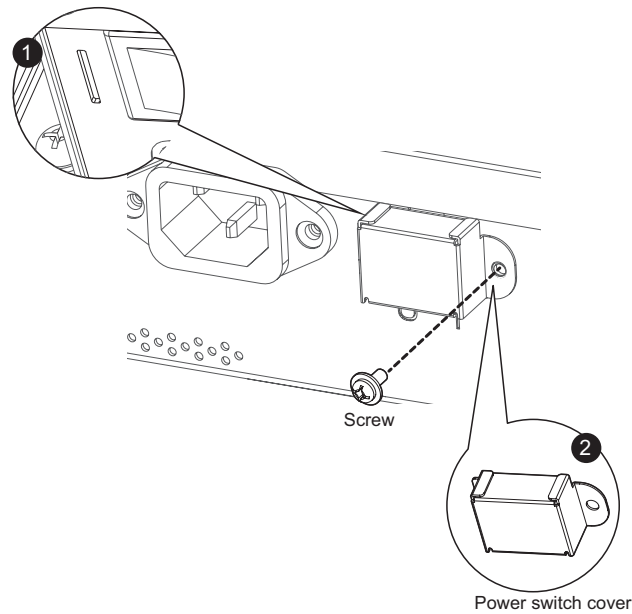

3.2 Connecting External Equipment (DVD/VCR/VCD)

3.2.1 Using COMPONENT video input

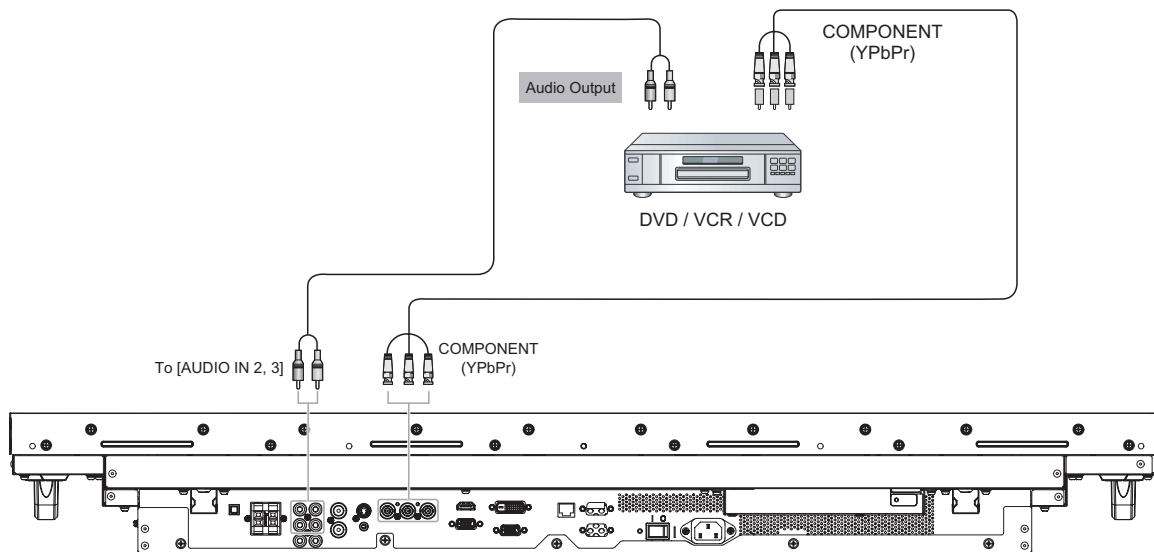

CONNECTING EXTERNAL EQUIPMENT

3.2.2 Using HDMI video input

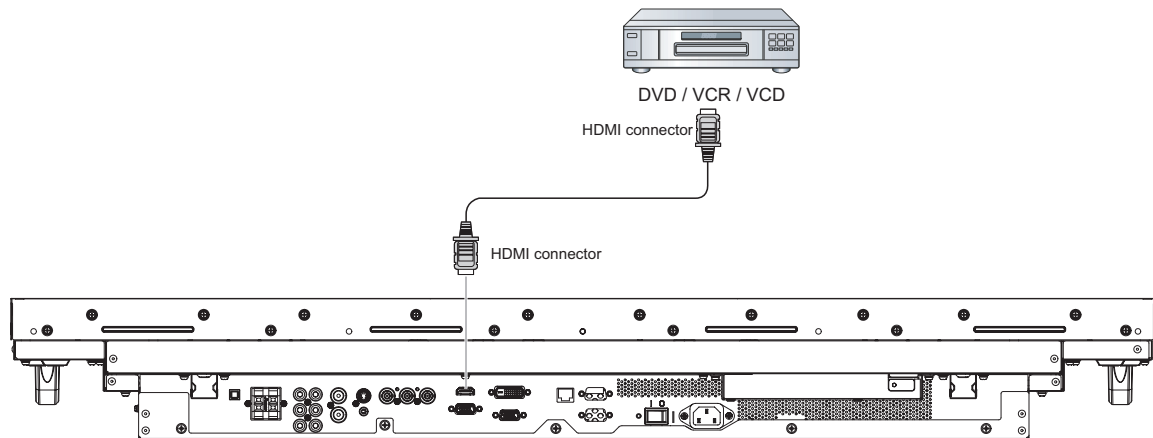

3.3 Connecting a PC

3.3.1 Using VGA input

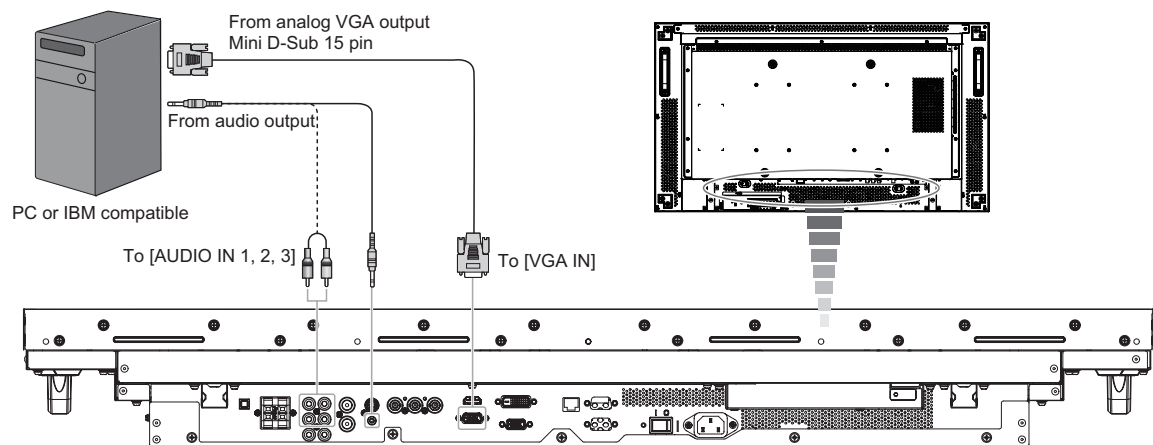

CONNECTING EXTERNAL EQUIPMENT

3.3.2 Using DVI input

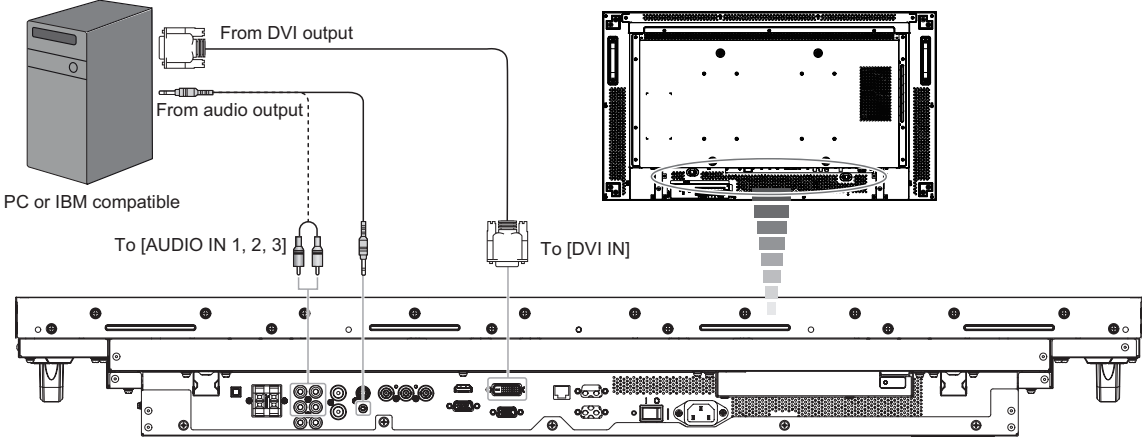

3.3.3 Using HDMI input

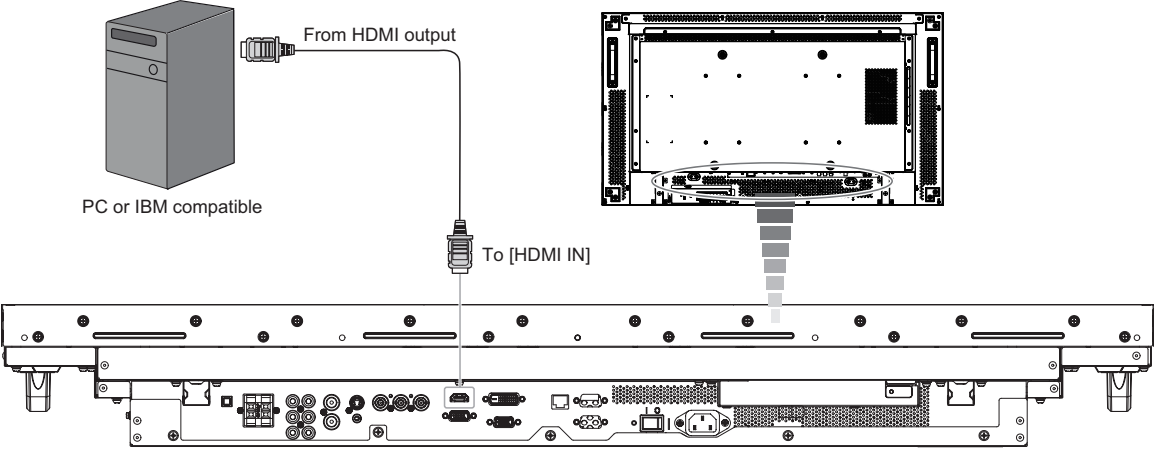

CONNECTING EXTERNAL EQUIPMENT

3.4 External Audio Connection

3.4.1 Connecting external speakers

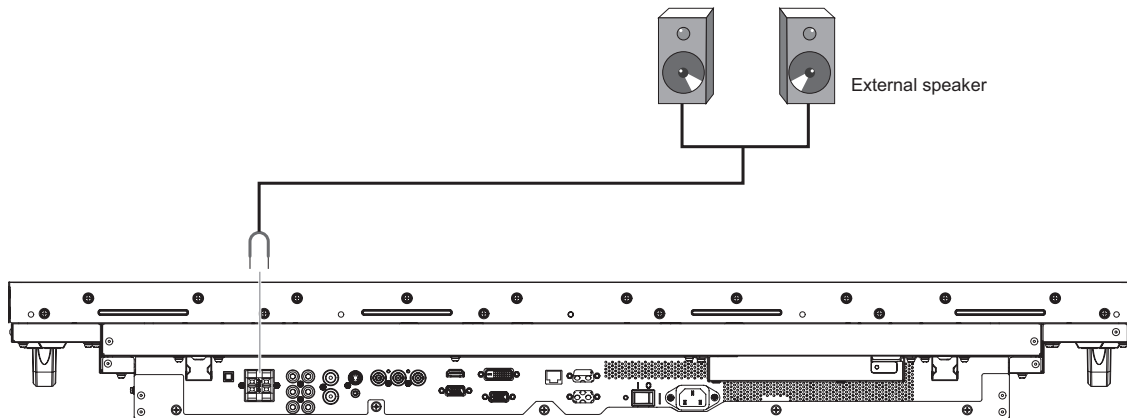

3.4.2 Connecting an external audio device

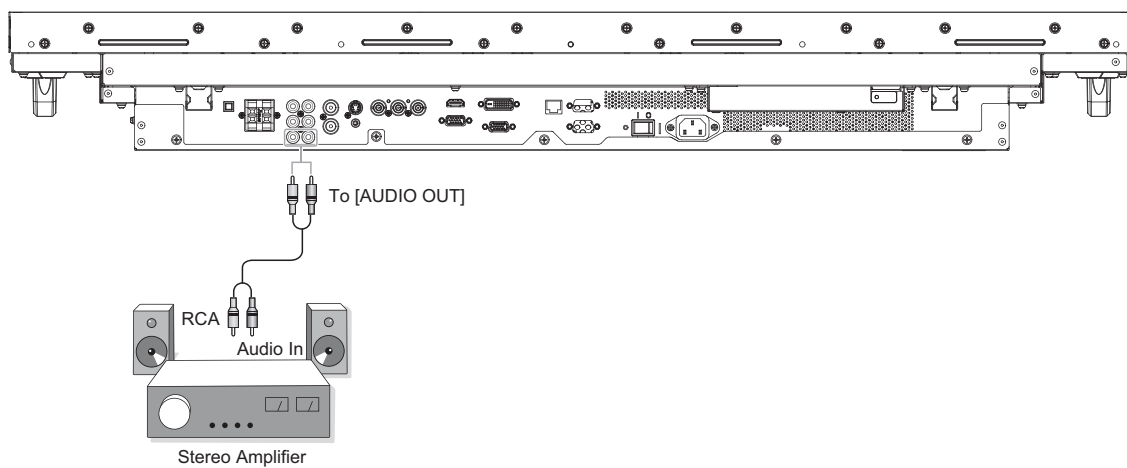

CONNECTING EXTERNAL EQUIPMENT

3.5 Connecting Multiple Displays in a Daisy-chain Configuration

You can interconnect multiple displays to create a daisy-chain configuration for applications such as a video wall.

▲ NOTE: Maximum 25 displays (5x5) can be used in a daisy-chain configuration.

3.5.1 Video connection

Connect one of the following:

- Connect the [RS232C OUT] connector of display 1 to the [RS232C IN] connector of display 2.
- Connect the [VGA OUT] connector of display 1 to the [VGA IN] connector of display 2.
- Connect the [VIDEO OUT] connector of display 1 to the [VIDEO IN] connector of display 2.

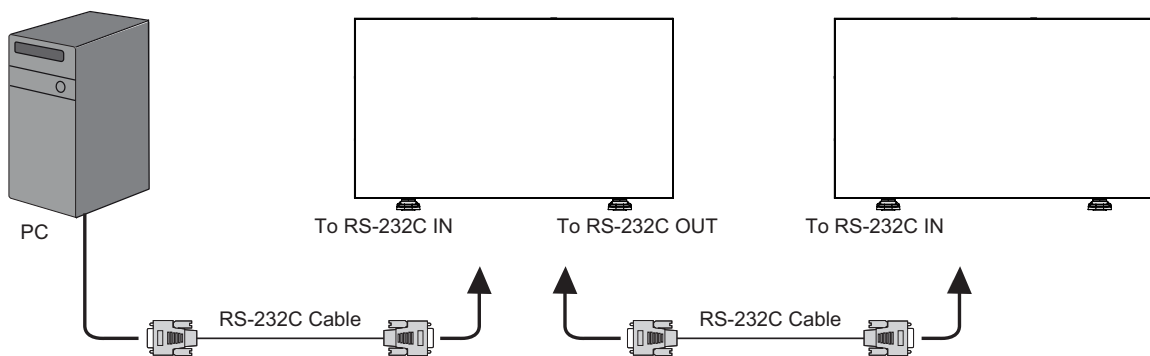

3.5.2 Audio connection

Do one the following connections:

- Connect the [AUDIO OUT] connector of display 1 to the [AUDIO IN 2] OR [AUDIO IN 3] connector of display 2.
- Connect the [VGA OUT] connector of display 1 to the [VGA IN] connector of display 2.
- Connect the [VIDEO OUT] connector of display 1 to the [VIDEO IN] connector of display 2.

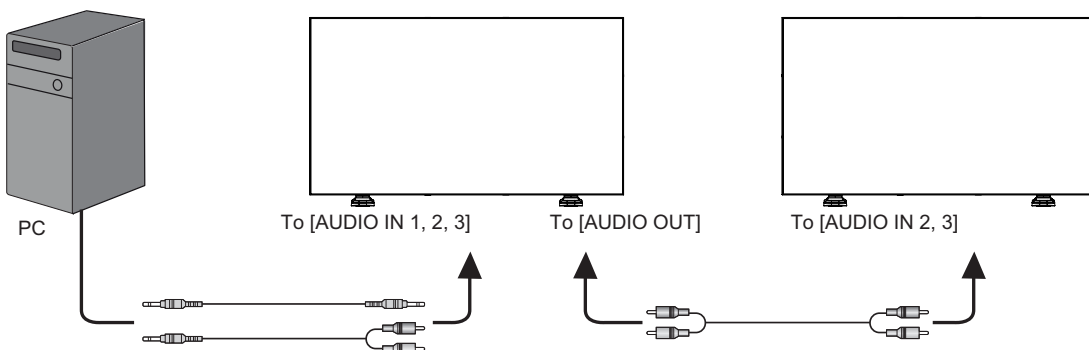

CHAPTER 4: OSD MENU

An overall view of the On-Screen Display (OSD) structure is shown below. You can use it as a reference for further adjusting your display.

4.1 Navigating the OSD Menu

4.1.1 Navigating the OSD menu using the remote control

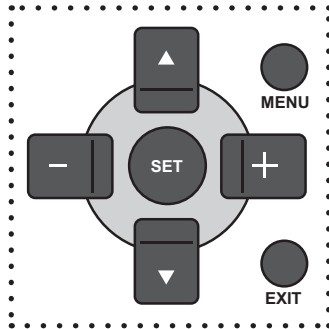

1. Press [**MENU**] button on the remote control to display the OSD menu.
2. Press [**▲**] or [**▼**] button to choose the item you want to adjust.
3. Press [**SET**] button to enter the submenu.
4. In the submenu, press [**▲**] or [**▼**] button to toggle among items, press [**+**] or [**-**] button to adjust settings. If there is a submenu, press [**SET**] button to enter the submenu.
5. Press [**EXIT**] button to return to the previous menu, or press [**MENU**] button to exit the OSD menu.

4.1.2 Navigating the OSD menu using the display's control buttons

1. Press [**MENU**] button to display the OSD menu.
2. Press [**+**] or [**-**] button to choose the item you want to adjust.
3. Press [**SOURCE**] button to enter the submenu.
4. In the submenu, press [**▲**] or [**▼**] button to toggle among items, press [**+**] or [**-**] button to adjust settings. If there is a submenu, press [**SOURCE**] button to enter the submenu.
5. Press [**MENU**] button to return to the previous menu, or press [**MENU**] button several times to exit the OSD menu.

OSD MENU

4.2 OSD Menu Overview

4.2.1 PICTURE menu

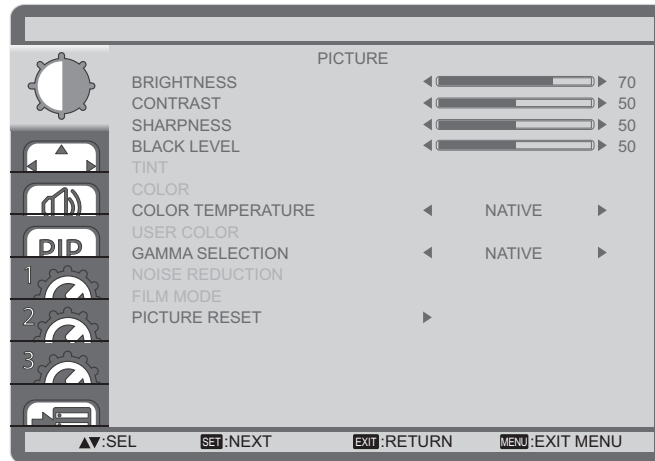

Item	Description
BRIGHTNESS	Adjust the overall image brightness by changing the intensity of the LCD panel's backlight.
CONTRAST	Adjust to sharpen the picture quality. The black portions of the picture become richer in darkness and the white become brighter.
SHARPNESS	Adjust to improve the image detail.
BLACK LEVEL	Adjust to change the image brightness.
TINT	Use the [+] or [-] button to adjust. Press the [+] button and the flesh tone color turns slightly green. Press the [-] button and the flesh tone color turns slightly purple. ▲ NOTE: This item is functional for HDMI(Video mode), S-Video, Video, and YPbPr inputs only.
COLOR	Adjust to increase or decrease the intensity of colors in the image. ▲ NOTE: This item is functional for HDMI (Video mode), S-Video , Video , and YPbPr inputs only.
COLOR TEMPERATURE	Select a color temperature for the image. A lower color temperature will have a reddish tint, whilst a higher color temperature gives off a more bluish tint. The options are: {3000K} / {4000K} / {5000K} / {6500K} / {7500K} / {9300K} / {10000K} / {NATIVE} / {USER}.
USER COLOR	With this function you can adjust the color tones of the image precisely by changing the R (Red), G (Green) and B (Blue) settings independently. ▲ NOTE: This item is functional only when {COLOR TEMPERATURE} is set to {USER}.
GAMMA SELECTION	Gamma is what controls the overall brightness of an image. Images which are not corrected properly can appear too white or too dark, so controlling the gamma properly can have a huge influence on the overall picture quality of your display. The options are: {NATIVE} / {2.2} / {2.4} / {S GAMMA}.

OSD MENU

Item	Description
NOISE REDUCTION	Adjust to remove the noise in the image. You can select a suitable noise reduction level. The options are: {OFF} / {LOW} / {MIDDLE} / {HIGH}. ▲ NOTE: This item is functional for HDMI (Video mode), S-Video , Video , and YPbPr inputs only.
FILM MODE	Choose to turn on or off the film mode frame conversion function. <ul style="list-style-type: none"> {AUTO} - Enable the film mode frame conversion function for movies and motion pictures. The display converts a 24 frames-per-second (24 fps) input signal format to DVD video signal format. Once this function is enabled, it is recommended that you set the {SCAN CONVERSION} function to {PROGRESSIVE}. {OFF} - Disable the film mode frame conversion function. This mode is suitable for TV broadcasting and VCR signals.
PICTURE RESET	Reset all settings in the Picture menu to factory preset values.

4.2.2 SCREEN menu

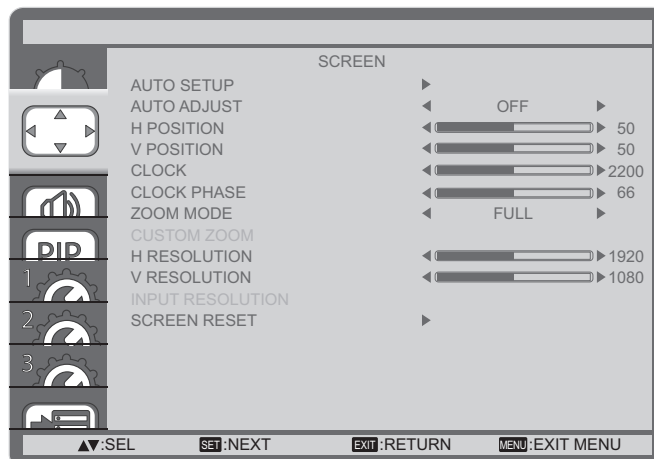





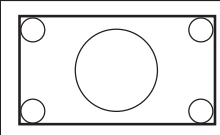
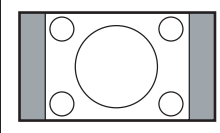
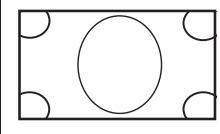



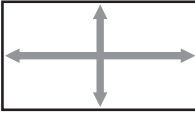

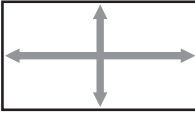

Item	Description
AUTO SETUP	Use this function to let the display automatically optimize the display of VGA input image. ▲ NOTE: This item is functional for VGA input only.
AUTO ADJUST	Choose to let the display detect and display available signal sources automatically. <ul style="list-style-type: none"> {ON} - Set the display to display the image automatically once a signal is connected. {OFF} - Once a signal is connected, it can only be selected manually.
H POSITION	Press the [+] button to move the image to the right, or [-] to move the image to the left.
V POSITION	Press the [+] button to move the image up, or [-] to move the image down.
CLOCK	Adjust the width of the image. ▲ NOTE: This item is functional for VGA input only.
CLOCK PHASE	Adjust to improve the focus, clarity and stability of the image. ▲ NOTE: This item is functional for VGA input only.

OSD MENU

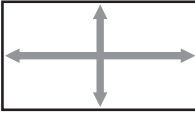
Item	Description
ZOOM MODE	<p>The pictures you receive may be transmitted in 16:9 format (wide screen) or 4:3 format (conventional screen). The 16:9 pictures sometimes have a black band at the top and bottom of the screen (letterbox format).</p> <p>This function allows you to optimize the picture display on screen. The following zoom modes are available for:</p> <ul style="list-style-type: none"> • PC mode: {FULL} / {NORMAL} / {CUSTOM} / {REAL}. • Video mode: {FULL} / {NORMAL} / {DYNAMIC} / {CUSTOM} / {REAL}.
	 <p>FULL This mode restores the correct proportions of pictures transmitted in 16:9 using the full screen display.</p>
	 <p>NORMAL The picture is reproduced in 4:3 format and a black band is displayed on either side of the picture.</p>
	 <p>DYNAMIC Fill the entire screen by stretching 4:3 pictures non-proportionally.</p>
	<p>CUSTOM Choose to apply the custom zoom settings in the Custom Zoom submenu.</p> <p>REAL This mode displays the image pixel-by-pixel on screen without scaling the original image size.</p>

OSD MENU

Item	Description										
CUSTOM ZOOM	<p>You can use this function to further customize the zoom settings to suit the image you want to display.</p> <p>▲ NOTE: This item is functional only when the {ZOOM MODE} setting is set to {CUSTOM}.</p> <table border="1" data-bbox="475 454 1401 1178"> <tbody> <tr> <td data-bbox="483 461 687 595">  </td> <td data-bbox="708 461 1393 595"> <p>ZOOM Expands the horizontal and vertical sizes of the image simultaneously.</p> </td> </tr> <tr> <td data-bbox="483 613 687 725">  </td> <td data-bbox="708 613 1393 725"> <p>H ZOOM Expands the horizontal size of the image only.</p> </td> </tr> <tr> <td data-bbox="483 743 687 855">  </td> <td data-bbox="708 743 1393 855"> <p>V ZOOM Expands the vertical size of the image only.</p> </td> </tr> <tr> <td data-bbox="483 873 687 985">  </td> <td data-bbox="708 873 1393 985"> <p>H POSITION Moves the horizontal position of the image left or right.</p> </td> </tr> <tr> <td data-bbox="483 1003 687 1115">  </td> <td data-bbox="708 1003 1393 1115"> <p>V POSITION Moves the vertical position of the image up or down.</p> </td> </tr> </tbody> </table>		<p>ZOOM Expands the horizontal and vertical sizes of the image simultaneously.</p>		<p>H ZOOM Expands the horizontal size of the image only.</p>		<p>V ZOOM Expands the vertical size of the image only.</p>		<p>H POSITION Moves the horizontal position of the image left or right.</p>		<p>V POSITION Moves the vertical position of the image up or down.</p>
	<p>ZOOM Expands the horizontal and vertical sizes of the image simultaneously.</p>										
	<p>H ZOOM Expands the horizontal size of the image only.</p>										
	<p>V ZOOM Expands the vertical size of the image only.</p>										
	<p>H POSITION Moves the horizontal position of the image left or right.</p>										
	<p>V POSITION Moves the vertical position of the image up or down.</p>										
INPUT RESOLUTION	<p>Set the resolution of the VGA input. This is only required when the display is unable to detect the VGA input resolution correctly.</p> <p>▲ NOTE: This item is functional for VGA input only.</p> <p>The options are:</p> <ul style="list-style-type: none"> • {1024x768 / 1280x768 / 1360x768} • {1400x1050 / 1680x1050} • {1600x1200 / 1920x1200} • {Auto}: Determines the resolution automatically. <p>The selected settings will become effective after turning off the power and turn it on again.</p>										
SCREEN RESET	<p>Reset all settings in the SCREEN menu to factory preset values.</p>										

OSD MENU

4.2.3 AUDIO menu

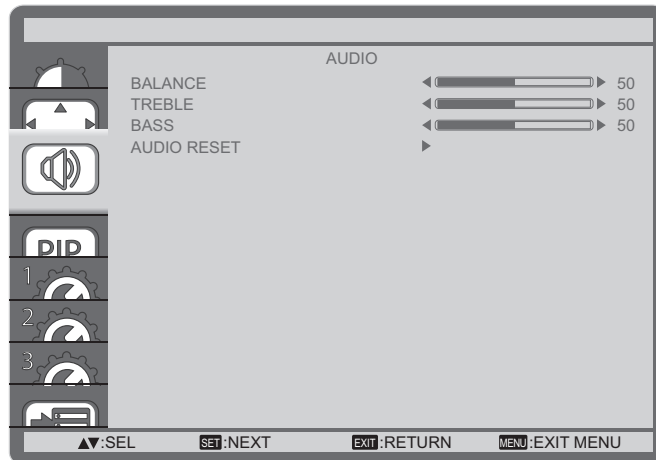

Item	Description
BALANCE	Adjust to emphasize left or right audio output balance.
TREBLE	Adjust to increase or decrease higher-pitched sounds.
BASS	Adjust to increase or decrease lower-pitched sounds.
AUDIO RESET	Reset all settings in the AUDIO menu to factory preset values.

4.2.4 PIP menu

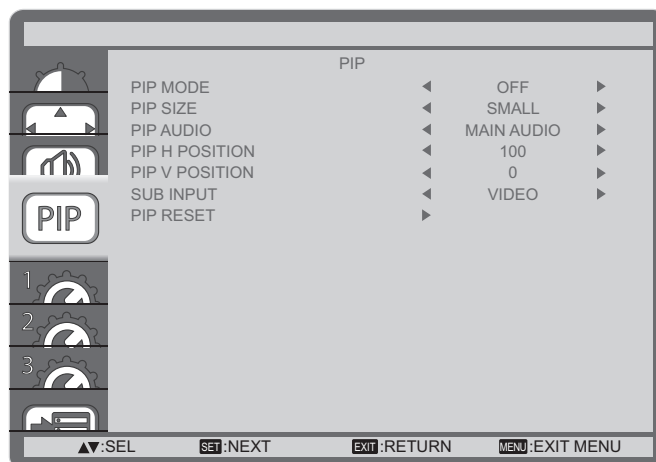

Item	Description
PIP MODE	Select the PIP (Picture-in-Picture) mode. The options are: { OFF } / { PIP } / { POP } / { SBS ASPECT } / { SBS FULL }.
PIP SIZE	Select the size of the sub picture in the PIP (Picture-in-Picture) mode. The options are: { SMALL } / { MIDDLE } / { LARGE }.
PIP AUDIO	Select the audio source in the PIP (Picture-in-Picture) mode. <ul style="list-style-type: none"> • {MAIN AUDIO} - Select audio from the main picture • {SUB AUDIO} - Select audio from the sub picture.
PIP H POSITION	Adjust the horizontal placement of the sub picture.
PIP V POSITION	Adjust the vertical placement of the sub picture.
SUB INPUT	Select the input signal for the sub-picture.

OSD MENU

Item	Description																																																																
PIP RESET	<p>Reset all settings in the PIP menu to factory preset values.</p> <p>▲ NOTES:</p> <ul style="list-style-type: none"> The PIP function is available only for certain signal source combinations as shown in the table below. The availability of the PIP function will also depend on the resolution of the input signal being used. <table border="1"> <thead> <tr> <th>Main Picture \ Sub Picture</th> <th>DVI</th> <th>VGA</th> <th>HDMI</th> <th>YPbPr</th> <th>S-Video</th> <th>Video</th> <th>Card OPS</th> </tr> </thead> <tbody> <tr> <td>DVI</td> <td>X</td> <td>X</td> <td>X</td> <td>X</td> <td>O</td> <td>O</td> <td>X</td> </tr> <tr> <td>VGA</td> <td>X</td> <td>X</td> <td>X</td> <td>X</td> <td>O</td> <td>O</td> <td>X</td> </tr> <tr> <td>HDMI</td> <td>X</td> <td>X</td> <td>X</td> <td>X</td> <td>O</td> <td>O</td> <td>X</td> </tr> <tr> <td>YPbPr</td> <td>X</td> <td>X</td> <td>X</td> <td>X</td> <td>O</td> <td>O</td> <td>X</td> </tr> <tr> <td>S-Video</td> <td>O</td> <td>O</td> <td>O</td> <td>O</td> <td>X</td> <td>X</td> <td>O</td> </tr> <tr> <td>Video</td> <td>O</td> <td>O</td> <td>O</td> <td>O</td> <td>X</td> <td>X</td> <td>O</td> </tr> <tr> <td>Card OPS</td> <td>X</td> <td>X</td> <td>X</td> <td>X</td> <td>O</td> <td>O</td> <td>X</td> </tr> </tbody> </table> <p>(O: PIP function available, X: PIP function unavailable)</p> <p>By pressing the [PIP ON/OFF] button on the remote control, you can change the mode in the order shown below:</p> <p>The resolutions in the PIP and POP modes are configured as follows:</p> <p>PIP SIZE {SMALL} : 320 x 240 pixels {MIDDLE} : 480 x 320 pixels {LARGE} : 640 x 480 pixels</p> <p>POP SIZE: 474 x 355 pixels</p> <p>▲ NOTE: The images displayed in the sub picture always fit the PIP sizes shown above irrespective of the aspect ratio of the input image.</p>	Main Picture \ Sub Picture	DVI	VGA	HDMI	YPbPr	S-Video	Video	Card OPS	DVI	X	X	X	X	O	O	X	VGA	X	X	X	X	O	O	X	HDMI	X	X	X	X	O	O	X	YPbPr	X	X	X	X	O	O	X	S-Video	O	O	O	O	X	X	O	Video	O	O	O	O	X	X	O	Card OPS	X	X	X	X	O	O	X
Main Picture \ Sub Picture	DVI	VGA	HDMI	YPbPr	S-Video	Video	Card OPS																																																										
DVI	X	X	X	X	O	O	X																																																										
VGA	X	X	X	X	O	O	X																																																										
HDMI	X	X	X	X	O	O	X																																																										
YPbPr	X	X	X	X	O	O	X																																																										
S-Video	O	O	O	O	X	X	O																																																										
Video	O	O	O	O	X	X	O																																																										
Card OPS	X	X	X	X	O	O	X																																																										

OSD MENU

4.2.5 CONFIGURATION1 menu

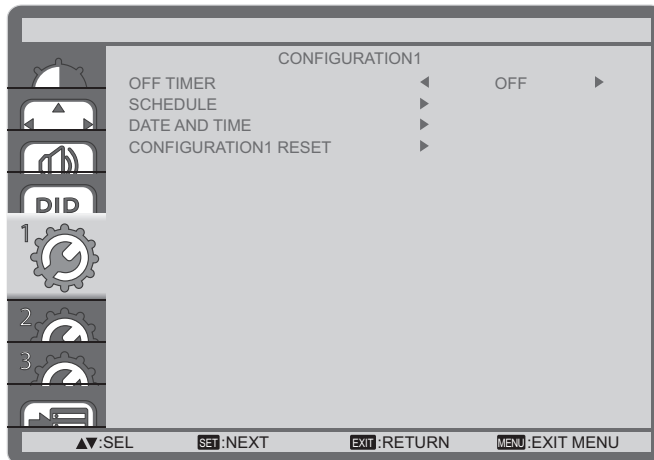

Item	Description
OFF TIMER	Set the display to turn itself off to standby mode within an amount of time specified. The options are: { OFF, 1HOUR ~ 24HOURS } from current time.
SCHEDULE	<p>This function allows you to program up to 7 (seven) different scheduled time intervals for the display to activate.</p> <p>You can select:</p> <ul style="list-style-type: none"> • The time for the display to turn on and turn off. • The days in a week for the display to activate. • Which input source the display will use for each scheduled activation period. <p>▲ NOTE: You should set up current date and time in {DATE AND TIME} menu before using this function.</p> <p>1. Press [SET] button to enter the submenu.</p> <div data-bbox="678 1350 1190 1637" data-label="Image"> </div> <p>2. Press [▲] or [▼] button to select a schedule item (item number 1 ~ 7), and then press [SET] button to mark it the item number.</p> <div data-bbox="678 1733 1190 2022" data-label="Image"> </div>

OSD MENU

Item	Description																
	<p>3. Press [+] or [-] button to select the schedule:</p> <ol style="list-style-type: none"> ① POWER-ON schedule: Press [▲] or [▼] button to set the hour and minute for the display to turn on. ② POWER-OFF schedule: Press [▲] or [▼] button to set the hour and minute for the display to turn off. <p>Select or leave an empty “_” for both the hour and minute slot if you do not want to use this power-on or power-off schedule.</p> <ol style="list-style-type: none"> ③ INPUT-SOURCE selection: Press [▲] or [▼] button to select an input source. If no input source is selected, the input source will remain the same as last selected. ④ DATE schedule: Press [+] button to select which day in a week this schedule item will be take effect, and then press the [SET] button. <p>4. For more schedule settings, press [EXIT] button and then repeat the steps above. A check mark in the box next to the number of the schedule item indicates that the selected schedule is in effect.</p> <p>▲ NOTES:</p> <ul style="list-style-type: none"> • The {EVERY DAY} selection in a schedule item takes priority over the other weekly schedules. • If the schedule overlaps, the scheduled power-on time takes priority over scheduled power-off time. • If there are two schedule items programmed for the same time, the highest numbered schedule takes priority. For example, if schedule items #1 and #2 both set the display to power on at 7:00 AM and off at 5:00 PM, then only schedule item # 1 will take effect. 																
<p>DATE AND TIME</p>	<p>Adjust the current date and time for the display's internal clock.</p> <div data-bbox="678 1265 1189 1556" style="border: 1px solid black; padding: 5px; margin: 10px auto; width: fit-content;"> <p style="text-align: center; margin: 0;">DATE AND TIME</p> <table style="width: 100%; border-collapse: collapse;"> <tr> <td style="text-align: left; padding: 2px;">YEAR</td> <td style="text-align: center; padding: 2px;">◀ 2011 ▶</td> </tr> <tr> <td style="text-align: left; padding: 2px;">MONTH</td> <td style="text-align: center; padding: 2px;">◀ 08 ▶</td> </tr> <tr> <td style="text-align: left; padding: 2px;">DAY</td> <td style="text-align: center; padding: 2px;">◀ 04 ▶</td> </tr> <tr> <td style="text-align: left; padding: 2px;">HOUR</td> <td style="text-align: center; padding: 2px;">◀ 20 ▶</td> </tr> <tr> <td style="text-align: left; padding: 2px;">MINUTE</td> <td style="text-align: center; padding: 2px;">◀ 20 ▶</td> </tr> <tr> <td style="text-align: left; padding: 2px;">DAYLIGHT SAVING TIME</td> <td style="text-align: center; padding: 2px;">◀ OFF ▶</td> </tr> <tr> <td colspan="2" style="padding: 2px;">CURRENT DATE TIME</td> </tr> <tr> <td colspan="2" style="text-align: center; padding: 2px;">2011 . 08 . 04 00 : 18 : 10</td> </tr> </table> <p style="font-size: small; margin: 0; text-align: center;">▲▼:SEL +/-:ADJ EXIT:RETURN MENU:EXIT MENU</p> </div> <ol style="list-style-type: none"> 1. Press [SET] button to enter the submenu. 2. Press [▲] or [▼] button to toggle among the {YEAR}, {MONTH}, {DAY}, {HOUR}, {MINUTE}, and {DAYLIGHT SAVING TIME} settings. 3. Press [+] or [-] button to adjust all settings except {DAYLIGHT SAVING TIME}. 	YEAR	◀ 2011 ▶	MONTH	◀ 08 ▶	DAY	◀ 04 ▶	HOUR	◀ 20 ▶	MINUTE	◀ 20 ▶	DAYLIGHT SAVING TIME	◀ OFF ▶	CURRENT DATE TIME		2011 . 08 . 04 00 : 18 : 10	
YEAR	◀ 2011 ▶																
MONTH	◀ 08 ▶																
DAY	◀ 04 ▶																
HOUR	◀ 20 ▶																
MINUTE	◀ 20 ▶																
DAYLIGHT SAVING TIME	◀ OFF ▶																
CURRENT DATE TIME																	
2011 . 08 . 04 00 : 18 : 10																	
<p>CONFIGURATION1 RESET</p>	<p>Reset all settings in the CONFIGURATION1 menu to factory preset values.</p>																

OSD MENU

4.2.6 CONFIGURATION2 menu

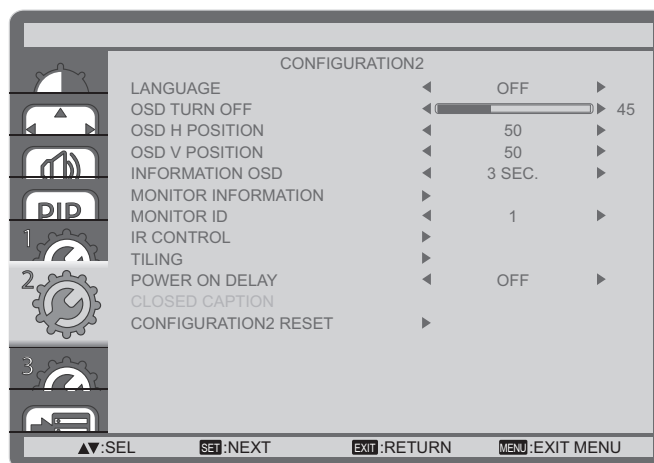

Item	Description
LANGUAGE	Select the language used in the OSD menu. The options are: {ENGLISH} / {DEUTSCH} / {FRANÇAIS} / {ITALIANO} / {ESPAÑOL} / {SVENSKA} / {日本語} / {中文}.
OSD TURN OFF	Set the period of time the OSD menu stays on the screen. The options are: {5 ~ 120} seconds.
OSD H POSITION	Adjust the horizontal position of the OSD menu.
OSD V POSITION	Adjust the vertical position of the OSD menu.
INFORMATION OSD	Set the period of time the information OSD displayed on the upper right corner of the screen. The information OSD will display when input signal is changed. The information OSD will remain on the screen with {OFF} selection. The options are: {OFF, 3 SEC. ~ 10 SEC.}.
MONITOR INFORMATION	Displays the information about your display, including MODEL NAME and SERIAL .
MONITOR ID	Set the ID number for controlling the display via the RS232C connection. Each display must have a unique ID number when multiple sets of this display are connected.
IR CONTROL	Select the operation mode of the remote control unit when multiple displays are connected via the RS232C connection. <ul style="list-style-type: none"> • {NORMAL} - All displays can be operated normally by the remote control. • {LOCK} - Lock the remote control function of this display. To unlock, press and hold the [DISPLAY] button on the remote control for 5 (five) seconds.

OSD MENU

Item	Description										
TILING	<p>With this function you can create a single large-screen matrix (video wall) that consists of up to 25 sets of this display (up to 5-set each at the vertical and horizontal side). This function requires a daisy-chain connection.</p> <div data-bbox="679 465 1193 658" style="border: 1px solid black; padding: 5px; margin: 10px auto; width: fit-content;"> <p style="text-align: center; margin: 0;">TILING</p> <table style="width: 100%; border-collapse: collapse;"> <tr> <td style="padding: 2px;">H MONITORS</td> <td style="padding: 2px; text-align: center;">◀ 1 ▶</td> </tr> <tr> <td style="padding: 2px;">V MONITORS</td> <td style="padding: 2px; text-align: center;">◀ 1 ▶</td> </tr> <tr> <td style="padding: 2px;">POSITION</td> <td style="padding: 2px; text-align: center;">◀ 1 ▶</td> </tr> <tr> <td style="padding: 2px;">FRAME COMP.</td> <td style="padding: 2px; text-align: center;">◀ OFF ▶</td> </tr> <tr> <td style="padding: 2px;">ENABLE</td> <td style="padding: 2px; text-align: center;">◀ OFF ▶</td> </tr> </table> <p style="font-size: small; margin: 0; text-align: center;">▲▼:SEL +/-:ADJ EXIT:RETURN MENU:EXIT MENU</p> </div>	H MONITORS	◀ 1 ▶	V MONITORS	◀ 1 ▶	POSITION	◀ 1 ▶	FRAME COMP.	◀ OFF ▶	ENABLE	◀ OFF ▶
H MONITORS	◀ 1 ▶										
V MONITORS	◀ 1 ▶										
POSITION	◀ 1 ▶										
FRAME COMP.	◀ OFF ▶										
ENABLE	◀ OFF ▶										
	<p>Example: 2 x 2 screen matrix (4 displays) H MONITORS = 2 displays V MONITORS = 2 displays</p> <div data-bbox="619 790 1246 1099" style="margin: 10px auto;"> </div> <p>Example: 5 x 5 screen matrix (25 displays) H MONITORS = 5 displays V MONITORS = 5 displays</p> <div data-bbox="632 1249 1222 1559" style="margin: 10px auto;"> </div> <ul style="list-style-type: none"> • H MONITORS - Select the number of displays on the horizontal side. • V MONITORS - Select the number of displays on the vertical side. • POSITION - Select the position of this display in the screen matrix. • FRAME COMP. - Choose to turn the frame compensation function on or off. If turned on, the display will adjust the image to compensate for the width of the display bezels in order to accurately display the image. • ENABLE: Choose to enable or disable the Tiling function. If enabled, the display will apply the settings in {H MONITORS}, {V MONITORS}, {POSITION}, and {FRAME COMP.}. <p>▲ NOTE: The Tiling function will be disabled when the [ON/OFF] button for PIP is pressed.</p>										

OSD MENU

Item	Description
POWER ON DELAY	<p>Select the delayed time until the power-on mode is activated after the power is turned on manually or automatically. This setting is useful in hiding start-up messages and powering on the connected devices at different timings.</p> <p>The options are: {OFF}, {2 SEC.}, {4 SEC.}, {6 SEC.}, {8 SEC.}, {10 SEC.}, {20 SEC.}, {30 SEC.}, {40 SEC.}, {50 SEC.}.</p>
CLOSED CAPTION	<p>Choose to display or hide captions.</p> <p>▲ NOTE: This item is functional for S-VIDEO or VIDEO input only.</p> <ul style="list-style-type: none"> • {OFF} - Captions are hidden. • {CC1} - Captions are displayed in sync with the primary audio. • {CC2} - Information (related to the primary audio) is displayed without sync. • {CC3} - Captions are displayed in sync with the secondary audio. • {CC4} - Information (related to the secondary audio) is displayed without sync. • {TT1 / TT2 / TT3 / TT4} - Four types of information not related to the displayed images are displayed. (For example, news and weather forecast.) <p>▲ NOTE: Check with each supplier of your video software and external video devices in advance whether they are compliant with EIA-608-A. If their video signals are not compliant with it, images may not be displayed correctly.</p>
CONFIGURATION2 RESET	<p>Reset all settings in the CONFIGURATION2 menu to factory preset values.</p>

OSD MENU

4.2.7 CONFIGURATION3 menu

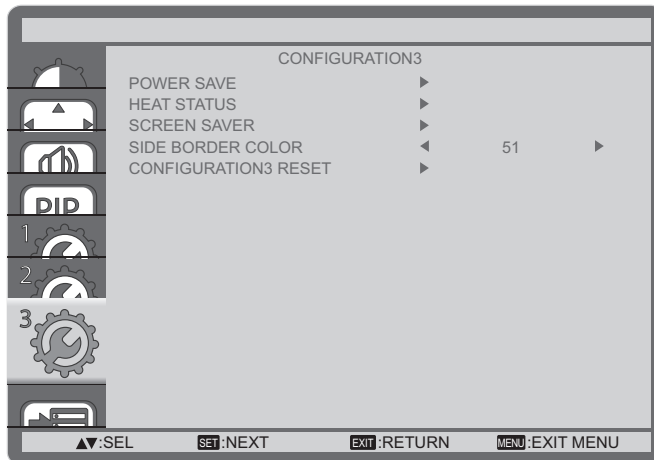

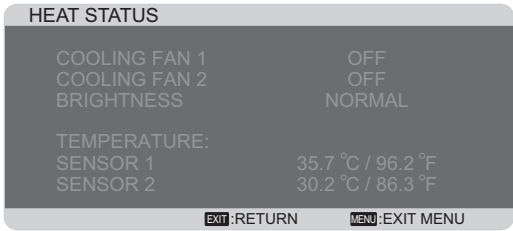
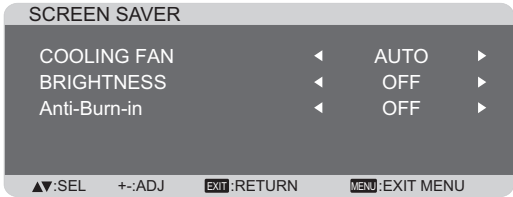
Item	Description
POWER SAVE	<p>Set the display to reduce the power automatically.</p>  <ul style="list-style-type: none"> • {RGB} - Select {ON} to let the display enter APM mode with no signal detected from the HDMI Graphic mode, HDMI, DVI-D, or VGA inputs after three successive cycles. • {VIDEO} - Select {ON} to let the display enter power saving mode with no signal detected from the HDMI Video mode or YPbPr inputs after three successive cycles.
HEAT STATUS	<p>This function allows you to check the thermal status of the display at any time.</p> 
SCREEN SAVER	 <ul style="list-style-type: none"> • {COOLING FAN} - Select {ON} to turn on the cooling fan all the time. Select {AUTO} to turn on/off the cooling fan according to the display's temperature.

OSD MENU

Item	Description
SCREEN SAVER	<p>▲ NOTES:</p> <ul style="list-style-type: none"> The default {AUTO} option will start running the cooling fan if the temperature of 65°C (152°F) is reached, and will keep running for 30 minutes after cooling down to the temperature of 62°C (144°F). A temperature-warning message will be shown on the screen once the temperature reaches 79°C. All key function except [Power] key will then be disabled. {BRIGHTNESS} - Select {ON} and the brightness of the image will be reduced to an appropriate level, and the Brightness setting in the Picture menu will become unavailable. {Anti-Burn-in} - Choose to enable the panel saving functions to reduce the risk of the “image persistence”. Select the time interval ({10 ~ 900} Seconds / {OFF}) for the display to slightly expand the image size and shift the position of pixels in four directions (up, down, left, or right).
SIDE BORDER COLOR	Adjust the brightness of the black areas displayed on both sides of 4:3 images.
CONFIGURATION3 RESET	Reset all settings in the CONFIGURATION3 menu to factory preset values.

4.2.8 ADVANCED OPTION menu

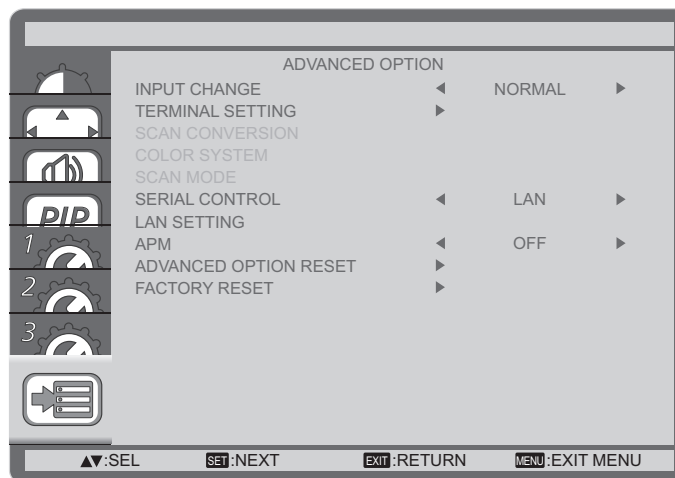

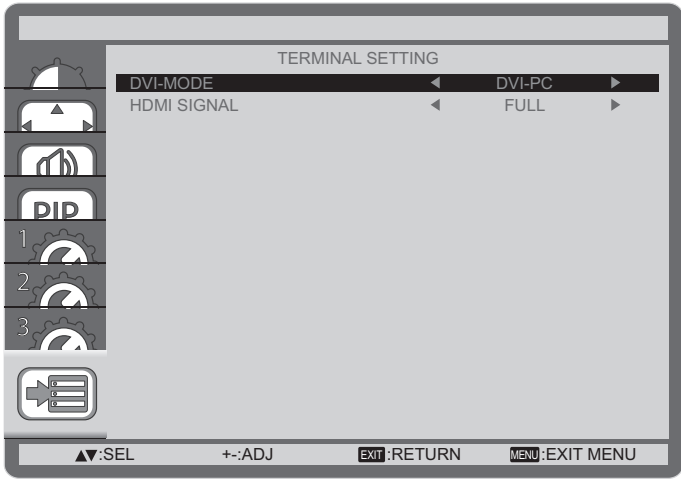

Item	Description
INPUT CHANGE	<p>Select the time for input switching as {NORMAL} or {QUICK}.</p> <p>▲ NOTE: The selection {QUICK} may cause a slight noise.</p>

OSD MENU

Item	Description
TERMINAL SETTING	<p>Select the mode to display the HDMI or DVI signal according to their signal format depending on their source device.</p> <ul style="list-style-type: none"> • {DVI MODE}: Used for DVI-D signal. <ul style="list-style-type: none"> • Select {DVI-PC} when the source device is a PC. • Select {DVI-HD} when the source device is a video device. • {HDMI SIGNAL}: Used for HDMI signal. <ul style="list-style-type: none"> • Select {LIMITED} when displaying the signal that uses 16 to 235 levels of 256 levels for each R, G, and B. • Select {FULL} when displaying the signal that uses all 256 levels (from level 0 to 255).  <p>The screenshot shows a grey OSD menu titled 'TERMINAL SETTING'. On the left is a vertical navigation bar with icons for Home, Back, Forward, and three numbered gear icons (1, 2, 3), and a right-pointing arrow icon. The main area shows two settings: 'DVI-MODE' set to 'DVI-PC' and 'HDMI SIGNAL' set to 'FULL'. At the bottom, there are four control labels: '▲:SEL', '+:ADJ', 'EXIT:RETURN', and 'MENU:EXIT MENU'.</p>
SCAN CONVERSION	<p>Choose to enable or disable the IP (Interlace to Progressive) conversion function.</p> <ul style="list-style-type: none"> • {PROGRESSIVE} - Enable the IP conversion function (recommended). Once enabled, the interlace input signal will be converted to progressive format for better display quality. • {INTERLACE} - Disable the IP function. This mode is suitable for displaying motion pictures, but it increases the chance of image retention.
COLOR SYSTEM	<p>Selects the Color System depends on your input video format. The options are: {AUTO} / {NTSC} / {PAL} / {SECAM} / {4.43NTSC} / {PAL-60}.</p> <p>▲ NOTE: This item is functional for S-VIDEO or VIDEO input only.</p>
SCAN MODE	<p>Change the display area of the image.</p> <ul style="list-style-type: none"> • {OVERSCAN} - Display about 95% of the original size of the image. The rest of the areas surrounding the image will be cut off. • {UNDERSCAN} - Display the image in its original size. <p>▲ NOTE: This item is functional for HDMI-Video timing input only.</p>
SERIAL CONTROL	<p>Select the network control port. The options are: {RS-232C} / {LAN}.</p> <p>▲ NOTE: If {LAN} is selected, then {RS-232C} will not be activated, even if a cable is attached, and vice versa.</p>

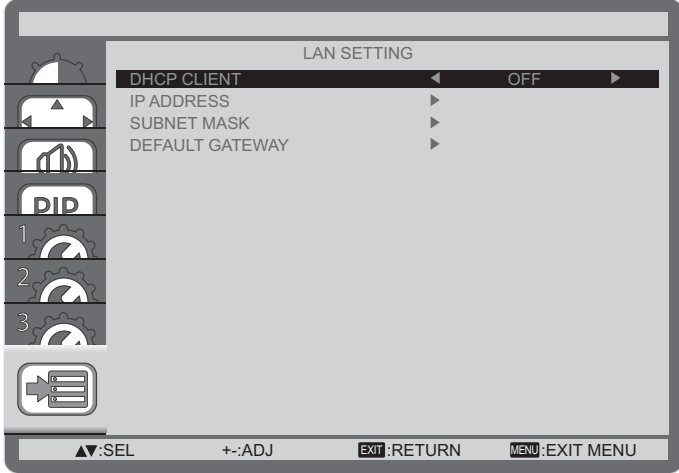
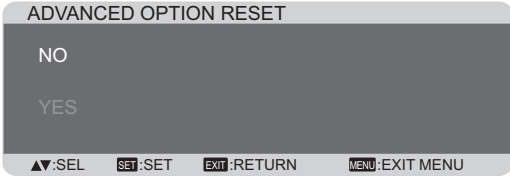
OSD MENU

Item	Description
LAN SETTING	<p>Assign {IP ADDRESS}, {SUBNET MASK}, and {DEFAULT GATEWAY} for the display.</p>  <ul style="list-style-type: none"> • DHCP - Choose to enable or disable the DHCP function. If enabled, the display will be assigned IP address, Subnet mask and Default gateway automatically. If disabled, you will be prompted to enter the following value manually. Finally, press [SET] button to store and save the chosen values.
APM	<p>Power save setting.</p> <ul style="list-style-type: none"> • {Off} - No signal, direct shutdown. (Default) • {On} - No signal, enter into Power Save mode.
ADVANCED OPTION RESET	<p>Reset all settings in the ADVANCED OPTION menu to factory preset values.</p> <ol style="list-style-type: none"> 1. Press [SET] button to enter the submenu. 2. Press [▲] or [▼] button to select {YES}, and then press [SET] button to do the reset. 
FACTORY RESET	<p>Reset all the settings in the OSD menus of {PICTURE}, {SCREEN}, {AUDIO}, {PIP}, {CONFIGURATION1}, {CONFIGURATION2}, {CONFIGURATION3}, and {ADVANCED OPTION} to factory preset values.</p> <ol style="list-style-type: none"> 1. Press [SET] button to enter the submenu. 2. Press [▲] or [▼] button to select {YES}, and then press [SET] button to do the reset. 

CHAPTER 5: INPUT MODE

5.1 VGA Resolution:

Standard Resolution	Active Resolution		Refresh Rate	Pixel Rate	Aspect Ratio	Stand for Mode
	H Pixels	V Lines				
VGA	640	480	60 Hz	25.175 MHz	4:3	Video Graphic Array
		480	72 Hz	31.5 MHz		
		480	75 Hz	31.5 MHz		
WVGA	720	400	70 Hz	33.75 MHz	16:9	Wide Video Graphic Array
SVGA	800	600	60 Hz	40 MHz	4:3	Super VGA
		600	75 Hz	49.5 MHz		
XGA	1024	768	60 Hz	65 MHz	4:3	Extended Graphic Array
		768	75 Hz	78.75 MHz		
WXGA	1280	768	60 Hz	79.5 MHz	5:3	Wide XGA
WXGA	1280	800	60 Hz	79.5 MHz	16:10	Wide XGA
SXGA	1280	960	60 Hz	108 MHz	4:3	Super XGA
SXGA	1280	1024	60 Hz	108 MHz	5:4	Super XGA
WXGA	1360	768	60 Hz	85.5 MHz	16:9	Wide XGA
WXGA	1366	768	60 Hz	85.5 MHz	16:9	Wide XGA
UXGA	1600	1200	60 Hz	162 MHz	4:3	Ultra XGA
HD1080	1920	1080	60 Hz	148.5 MHz	16:9	HD1080

5.2 SDTV Resolution:

Standard Resolution	Active Resolution		Refresh Rate	Pixel Rate	Aspect Ratio	Stand for Mode
	H Pixels	V Lines				
480i	720	480	29.97 Hz	13.5 MHz	4:3	Modified NTSC Standard
480p			59.94 Hz	27 MHz		
576i	720	480	25 Hz	13.5 MHz	4:3	Modified PAL Standard
576p			50 Hz	27 MHz		

5.3 HDTV Resolution:

Standard Resolution	Active Resolution		Refresh Rate	Pixel Rate	Aspect Ratio	Stand for Mode
	H Pixels	V Lines				
720p	1280	720	50 Hz	74.25 MHz	16:9	Normally DVB Mode
			60 Hz			
1080i	1920	1080	25 Hz	74.25 MHz	16:9	Normally ATSC Mode
			30 Hz			
1080p	1920	1080	50 Hz	148.5 MHz	16:9	Normally ATSC Mode
			60 Hz			

- The PC text quality is optimum in HD 1080 mode (1920 x 1080, 60Hz).
- Your PC display screen might appear different depending on the manufacture (and your particular version of Windows).

INPUT MODE

- Check your PC instruction book for information about connecting your PC to a monitor.
- If a vertical and horizontal frequency-select mode exists, select 60Hz (vertical) and 31.5KHz (horizontal). In some cases, abnormal signals (such as stripes) might appear on the screen when the PC power is turned off (or if the PC is disconnected). If so, press the **[INPUT]** button to enter the video mode. Also, make sure that the PC is connected.
- When horizontal synchronous signals seem irregular in RGB mode, check PC power saving mode or cable connections.
- The display settings table complies to the IBM/VESA standards, and based on the analog input.
- The DVI support mode is regarded as same to the PC support mode.
- The best timing for the vertical frequency to each mode is 60Hz.

CHAPTER 6: CLEANING AND TROUBLESHOOTING

6.1 Cleaning

Caution When Using the Display

- Do not bring your hands, face or objects close to the ventilation holes of the display. The top of the display is usually very hot due to the high temperature of exhaust air being released through the ventilation holes. Burns or personal injuries may occur if any body parts are brought too close. Placing any object near the top of the display could also result in heat related damage to the object as well as the display itself.
- Be sure to disconnect all cables before moving the display. Moving the display with its cables attached may damage the cables and thus cause fire or electric shock.
- Disconnect the power plug from the wall outlet as a safety precaution before carrying out any type of cleaning or maintenance procedure.

Front Panel Cleaning Instructions

- The front of the display has been specially treated. Wipe the surface gently using only a cleaning cloth or a soft, lint-free cloth.
- If the surface becomes dirty, soak a soft, lint-free cloth in a mild detergent solution. Wring the cloth to remove excess liquid. Wipe the surface of the display to remove dirt. Then use a dry cloth of the same type to dry.
- Do not scratch or hit the surface of the panel with fingers or hard objects of any kind.
- Do not use volatile substances such as insert sprays, solvents and thinners.

Cabinet Cleaning Instructions

- If the cabinet becomes dirty, wipe the cabinet with a soft, dry cloth.
- If the cabinet is extremely dirty, soak a lint-free cloth in a mild detergent solution. Wring the cloth to remove as much moisture as possible. Wipe the cabinet. Use another dry cloth to wipe over until the surface is dry.
- Do not allow any water or detergent to come into contact with the surface of the display. If water or moisture gets inside the unit, operating problems, electrical and shock hazards may result.
- Do not scratch or hit the cabinet with fingers or hard objects of any kind.
- Do not use volatile substances such as insert sprays, solvents and thinners on the cabinet.
- Do not place anything made from rubber or PVC near the cabinet for any extended periods of time.

CLEANING AND TROUBLESHOOTING

6.2 Troubleshooting

Symptom	Possible Cause	Remedy
No picture is displayed	<ol style="list-style-type: none"> 1. The power cord is disconnected. 2. The main power switch on the back of the display is not switched on. 3. The selected input has no connection. 4. The display is in standby mode. 	<ol style="list-style-type: none"> 1. Plug in the power cord. 2. Make sure the power switch is switched on. 3. Connect a signal connection to the display.
Interference displayed on the display or audible noise is heard	Caused by surrounding electrical appliances or fluorescent lights.	Move the display to another location to see if the interference is reduced.
Color is abnormal	The signal cable is not connected properly.	Make sure that the signal cable is attached firmly to the back of the display.
Picture is distorted with abnormal patterns	<ol style="list-style-type: none"> 1. The signal cable is not connected properly. 2. The input signal is beyond the capabilities of the display. 	<ol style="list-style-type: none"> 1. Make sure that the signal cable is attached firmly. 2. Check the video signal source to see if it is beyond the range of the display. Please verify its specifications with this display's specification section.
Display image doesn't fill up the full size of the screen	The zoom mode is not correctly set.	Use the Zoom mode or Custom zoom function in the Screen menu to fine tune display geometry and time frequency parameter.
Can hear sound, but no picture	Improperly connected source signal cable.	Make sure that both video inputs and sound inputs are correctly connected.

CLEANING AND TROUBLESHOOTING

<p>Can see picture but no sound is heard</p>	<ol style="list-style-type: none"> 1. Improperly connected source signal cable. 2. Volume is turned all the way down. 3. [MUTE] is turned on. 4. No external speaker connected. 	<ol style="list-style-type: none"> 1. Make sure that both video inputs and sound inputs are correctly connected. 2. Press [VOL UP] or [VOL DOWN] button to hear sound. 3. Switch MUTE off by using the [MUTE] button. 4. Connect external speakers and adjust the volume to a suitable level.
<p>Some picture elements do not light up</p>	<p>Some pixels of the display may not turn on.</p>	<p>This display is manufactured using an extremely high level of precision technology: however, sometimes some pixels of the display may not display. This is not a malfunction.</p>
<p>After-Images can still be seen on the display after the display is powered off. (Examples of still pictures include logos, video games, computer images, and images displayed in 4:3 normal mode)</p>	<p>A still picture is displayed for an over extended period of time</p>	<p>Do not allow a still image to be displayed for an extended period of time as this can cause a permanent after-image to remain on the display.</p>

CHAPTER 7: TECHNICAL SPECIFICATIONS

PN-46

Display:

Item	Specifications
Screen Size (Active Area)	46" LCD
Aspect ratio	16:9
Number of pixels	1920 (H) x 1080 (V)
Pixel pitch	0.53 (H) x 0.53 (V) [mm]
Displayable colors	1073.7M colors
Brightness (typical)	700 cd/m ²
Contrast ratio (typical)	4000:1
Viewing angle	178 degrees

In/Out Terminals:

Item	Specifications
Speaker Output	Internal Speaker 10W (L) + 10W (R) [RMS]/8Ω 1 Way 1 Speaker System 82 dB/W/M/160 Hz ~ 13 KHz
Audio Output	RCA Jack x 1 0.5V [rms] (Normal)/ 2 Channel (L+R)
Audio Input	RCA Jack x 2 3.5 mm Stereo x 1 0.5V [rms] (Normal)/ 2 Channel (L+R)
RS232C	D-Sub Jack x 2 (9 pin) TXD + RXD (1:1)
RJ-45	RJ-45 Jack x 1 (8 pin) 10/100 LAN Port
HDMI Input	HDMI Jack x 1 (Type A) (18 pin) Digital RGB: TMDS (Video + Audio) MAX: Video - 720p, 1080p, 1920 x 1080/60 Hz (WUXGA) Audio - 48 KHz/ 2 Channel (L+R) Supports LPCM only
DVI-D Input	DVI-D jack Digital RGB: TMDS (Video)
VGA Input	D-Sub Jack x 1 (15 pin) Analog RGB: 0.7V [p-p] (75Ω), H/CS/V: TTL (2.2kΩ), SOG: 1V [p-p] (75Ω) MAX: 720p, 1080p, 1920 x 1080/60 Hz (WUXGA)
VGA Output	D-Sub Jack x 1 (15 pin) Analog RGB: 0.7V [p-p] (75Ω), H/CS/V: TTL (2.2kΩ), SOG: 1V [p-p] (75Ω) MAX: 720p, 1080p, 1920 x 1080/60 Hz (WUXGA)
Component Input	BNC Jack x 3 Y: 1V [p-p] (75Ω), Pb: 0.7V [p-p] (75Ω), Pr: 0.7V [p-p] (75Ω) MAX: 480i, 576i, 480p, 576p, 720p, 1080i, 1080p
Video Input	S-VIDEO Jack x 1 Y: 1V [p-p] (75Ω), C: 0.3V [p-p] (75Ω)
Video Output	BNC Jack x 1 Composite 1V [p-p] (75Ω)

TECHNICAL SPECIFICATIONS

General:

Item	Specifications
Power Supply	AC 100 ~ 240V, 50 ~ 60Hz
Power Consumption (Max)	270W
Power Consumption (typ.)	220W
Power Consumption (Standby & Off)	< 0.5W (RS232 in active)
Dimensions (With Stand) [W x H x D]	1023.68(W) x 615.6 (H) x 329.8(D)mm
Dimensions (Without Stand) [W x H x D]	1023.68(W) x 578.27(H) x 126.1(D)mm
Weight (With Stand)	26.0 Kg
Weight (Without Stand)	24.3 Kg
Gross Weight	31.5 Kg

Environmental Condition:

Item	Specifications	
Temperature	Operational	0 ~ 40°C
	Storage	-20 ~ 60°C
Humidity	Operational	20 ~ 80% RH (No condensation)
	Storage	5 ~ 95% RH (No condensation)
Altitude	Operational	0 ~ 3,000 m

Internal Speaker:

Item	Specifications
Type	1 Way 1 Speaker
Input	10 W (RMS)
Impedance	8Ω
Output Sound Pressure	82 dB/W/M
Frequency Response	160 Hz ~ 13 KHz

▲ NOTE: All specifications are subject to change without prior notice.