



**NETWORK  
TECHNOLOGIES  
INCORPORATED**

1275 Danner Dr    Tel:330-562-7070  
Aurora, OH 44202    Fax:330-562-1999  
www.networktechinc.com

# **ENVIROMUX-H2**

## **Hydrogen Gas Detector**

User Instructions



Important: Keep these User Instructions for reference

# TABLE OF CONTENTS

GENERAL SAFETY INFORMATION	3
Intended Use	3
List of Warnings and Cautions	3
USE INSTRUCTIONS AND LIMITATIONS	4
Use For	4
Do Not Use For	4
General Description	4
Features	4
Specifications	5
INSTALLATION AND OPERATION INSTRUCTIONS	5
Location	5
Installation	5
Power Up	6
Operation	6
Alarms	7
Trouble Indicator	7
MAINTENANCE	7
Testing	7
Cleaning	7
Sensor Poisons	8
WIRING METHODS	8

## GENERAL SAFETY INFORMATION

### INTENDED USE

The ENVIROMUX-H2 Hydrogen Gas Detector is a low voltage (12-24VAC or VDC) electronic detector of hydrogen gas. The detector is designed for connection to alarm control panels. Alarm control panels that work on 12 or 24 VDC can provide battery backup to the detector. This gas detector is NOT designed to detect smoke, fire or carbon monoxide.

### LIST OF WARNINGS AND CAUTIONS



- Each person using this equipment must read and understand the information in these *User Instructions* before use. Use of this equipment by untrained or unqualified persons, or use that is not in accordance with these *User Instructions*, may adversely affect product performance and **result in sickness or death**.
- Use only for monitoring the gas which the sensor and detector are designed to monitor. Failure to do so may result in exposures to gases not detectable and **cause sickness or death**. For proper use, see supervisor or *User Instructions*, or call Macurco Technical Service.
- Detector may not function effectively below 32 °F or above 120°F. Using the detector outside of this temperature range may adversely affect product performance and **result in sickness or death**.
- This detector helps monitor for the presence and concentration level of certain specified airborne gases. Misuse may produce an inaccurate reading, which means that higher levels of the gas being monitored may be present and could result in overexposure and **cause sickness or death**.
- The detector is not designed to measure compliance with Occupational Safety and Health Administration (OSHA) commercial or industrial standards.
- When the unit is powered up it performs a self-test during which the green LED light will blink for a period of one and one half to two minutes. Afterward, the green LED light will turn on continuously to indicate the unit is in normal operation (ARMED). If the self-test fails or the green LED light does not turn on continuously do not use. Failure to do so may adversely affect product performance and **result in sickness or death**.
- Immediately exit the environment if there is an alarm condition on the detector. **Failure to do so may result in sickness or death**.
- This detector will only indicate the presence of combustible gas at the sensor. Combustible gas may be present in other areas. Accommodation spaces should be well ventilated when household cleaning supplies or similar contaminants are used.
- Do not cover or obstruct visual alarm LED. Doing so may adversely affect product performance and **result in sickness or death**.
- Do not disassemble unit or attempt to repair or modify any component of this detector. This detector contains no user serviceable parts, and substitution of components may adversely affect product performance and **result in sickness or death**.

---

### CAUTION

- Avoid the use of harsh cleaning materials, abrasives and other organic solvents. Such materials may permanently scratch the surfaces, damage the sensor, labels, or instrument housing.
  - If you have any doubts about the applicability of the equipment to your job situation, consult an industrial hygienist.
-

## USE INSTRUCTIONS AND LIMITATIONS

### WARNING

Each person using this equipment must read and understand the information in these *User Instructions* before use. Use of this equipment by untrained or unqualified persons, or use that is not in accordance with these *User Instructions*, may adversely affect product performance and **result in sickness or death**.

---

### USE FOR

The ENVIROMUX-H2 is a low voltage (12-24VAC or VDC) dual relay, hydrogen detector. The unit is designed to work with control panel or other building management equipment to help monitor levels of hydrogen gas in a room or a facility where hydrogen gas may be present, for example where forklifts, backup power supplies, or golf carts battery charging stations are present.

### WARNING

Use only for monitoring the gas which the sensor and detector are designed to monitor. Failure to do so may result in exposures to gases not detectable and **cause sickness or death**. For proper use, see supervisor or *User Instructions*, or call Macurco Technical Service.

---

### DO NOT USE FOR

The ENVIROMUX-H2 is NOT intended for use in industrial applications such as refineries, chemical plants, etc. Do NOT mount the detector where the normal ambient temperature is below 40°F (4.4°C) or above 120°F (49°C). The ENVIROMUX-H2 mounts on a 4x4 or 2-gang electrical box supplied by the contractor. DO NOT install the detector inside another enclosure or protective cover unless it has good air flow through it. The detector is NOT designed to detect smoke, fire or carbon monoxide. Do NOT mount the detector in a corner.

### WARNING

ENVIROMUX-H2 may not function effectively below 32 °F or above 120°F. Using the detector outside of this temperature range may adversely affect product performance and **result in sickness or death**.

---

### GENERAL DESCRIPTION

The ENVIROMUX-H2 is a low voltage (12-24VAC or VDC) electronic detector of hydrogen gas. The ENVIROMUX-H2 is designed for connection to alarm control panels to help monitor levels of hydrogen gas. This gas detector is NOT designed to detect smoke, fire or carbon monoxide.

### FEATURES

- Detects Hydrogen Gas
- SPDT Alarm and N.C. Trouble Relays
- Can Be Self-Restoring or Latching
- Electronic Sensors: No Maintenance or Recalibration
- Temperature Compensated
- Simple Installation and Operation
- Supervised Sensor

### SPECIFICATIONS

- SIZE: 4 ½ X 5 X 1 5/8 inches
- SHIPPING WEIGHT: 0.54 pound
- VOLTAGE: 12 to 24 VAC or VDC
- CURRENT (non-alarm): 45 ma @ 12 VDC, 22 ma @ 24 VDC, 65 ma @ 12 VAC, 45 ma @ 24 VAC
- CURRENT (in alarm): 70 ma @ 12 VDC, 35 ma @ 24 VDC, 100 ma @ 12 VAC, 65 ma @ 24 VAC

- COLOR: White
- SENSOR MAINTENANCE: Not required
- ALARM RELAY RATING: 0.125 AMPS, 40V, 3VA
- TROUBLE RELAY: 0.250 AMPS, 40V, 10VA
- OPERATING TEMPERATURE RANGE: 32° to 120° F
- ALARM SET POINT: 10% LEL HYDROGEN

## INSTALLATION AND OPERATING INSTRUCTIONS

The following instructions are intended to serve as a guideline for the use of the ENVIROMUX-H2 Hydrogen Gas Detector. It is not to be considered all-inclusive, nor is it intended to replace the policy and procedures for each facility.

### WARNING

This detector helps monitor for the presence and concentration level of certain specified airborne gases. Misuse may produce an inaccurate reading, which means that higher levels of the gas being monitored may be present and could result in overexposure and **cause sickness or death**. For proper use, see supervisor or *User Instructions*, or call Macurco Technical Service.

## LOCATION

The ENVIROMUX-H2 is NOT intended for use in industrial applications such as refineries, chemical plants, etc. The unit can cover approximately 900 sq. ft. The coverage depends on air movement in the room or facility. Locate the unit high in the room where storage batteries are being charged, or where there may be other hydrogen sources. Extra detectors may be needed near any areas where people work or the air is stagnant.

### WARNING

This product is intended for use in ordinary indoor locations of family living units and office workspaces. The detector is not designed to measure compliance with Occupational Safety and Health Administration (OSHA) commercial or industrial standards.

## INSTALLATION

1. Mount the detector high on a wall about one foot down from the ceiling. Use the same spacing as for smoke detectors- 30-foot centers, 900 square feet per detector.
2. The three part plastic case allows the detector to be either surface mounted or installed over a four-inch square or double gang electrical box, providing a near flush mount. The detector snap on front cover will need to be removed before installation. To remove it, lightly pry the front cover off of the mounting plate (middle section) with a coin or flat screwdriver inserted into the vent at the bottom. The cover will snap off exposing the electronics and mounting plate.



3. For flush mount, remove the 2 screws and rear cover from the mounting plate and use the appropriate hole-pattern for installation. The four holes toward the center of the mounting plate match the hole-pattern of a double gang electrical box. The four holes near the corners match the pattern of a four-inch square box. Mount the detector so the "TOP" marked side of the mounting plate is at the highest side. Snap the front cover back on when finished, making sure that the lights line up with the access holes.
4. When using the detector with normally closed initiating circuits, use the Com. and N.C. alarm relay connections.
5. See wiring diagram and information below and on page 8 for connections of the ENVIROMUX-H2.

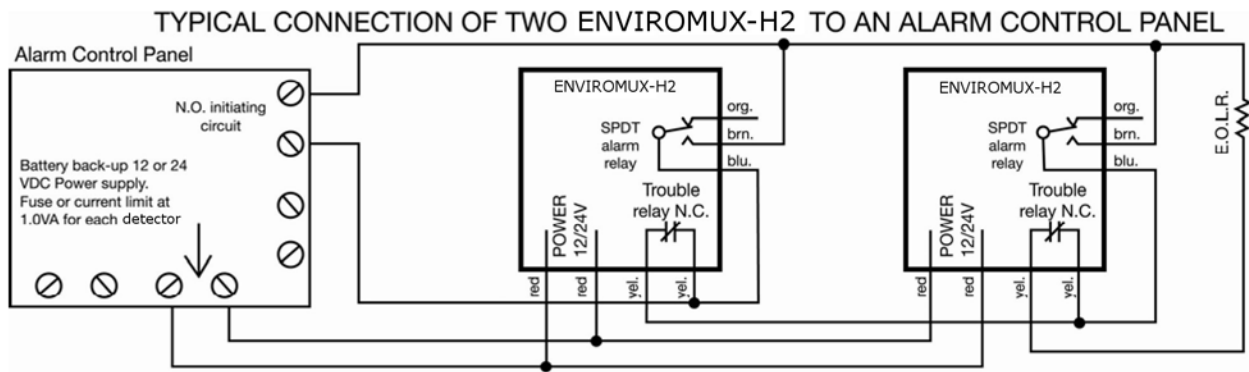

Alarm Control panels that operate on 12VDC or 24VDC are available with many features including battery back-up, automatic phone dialers, auxiliary relays.

6. The ENVIROMUX-H2 uses a full wave bridge rectifier at its power input, so that it is independent of the polarity of the input power. It can operate on DC or AC voltages between 12 and 24 volts.
7. A switching regulator is used to efficiently match the wide input voltage range to the fixed, internal power system. As a result the power consumption is fairly constant at about 0.75 watts in normal operation, and 1.0 watt in alarm.
8. The alarm control panel zone inputs must be terminated with end of line resistors (E.O.L.R.), which are provided with the panel. The detector does not have an internal audible sounder and must be connected to an audible device that provides at least 85 DB sound output.

## POWER UP



When the unit is powered up it performs a self-test during which the green LED light blinks for a period of one and one half to two minutes. Afterwards, the green LED light will turn on continuously to indicate the unit is in normal operation (ARMED). If the self-test fails or the green LED light does not turn on continuously do not use. Failure to do so may adversely affect product performance and **result in sickness or death.**

When power is first applied to the detector, it will go through a warm-up period of one and one half to two minutes, during which alarms are inhibited. The green LED light will turn on and off during the delay period. The green light will turn on continuously (ARMED) afterwards to indicate the unit is in normal operation.

## OPERATION

1. Once the ENVIROMUX-H2 is operational (ARMED) the green light will be on continuously. If gas is detected the red LED (ALARM) turns on and the SPDT alarm relay activates to indicate the alarm condition.
2. In the configuration, as shipped from the factory, the detector is self-restoring. When the air clears of gas, the red light turns off and the relay switches to its normal state. A jumper wire on the circuit board can be clipped to allow the unit to latch in upon alarm. Once latched in, power will need to be interrupted to unlatch the alarm condition.
  - The detector can be modified, either before or after installation, to have a latching output. Pull off the cover and locate the jumper wire labeled "CLIP FOR LATCH IN" on the printed circuit board in the upper right hand side. Clip or cut this jumper wire and separate the wire ends. Now the unit will stay in alarm (once gas has exceeded the pre-set threshold) until the power is interrupted. When replacing the cover, make sure the lights line up with their access holes.
3. The detector has a supervisory circuit of critical functions. A trouble condition, due to failure of a non-reliable component, results in both lights switching on and off and the normally closed trouble relay opening. A power failure also causes the trouble relay to open.

## ALARMS

### WARNING

Immediately exit any environment if there is an alarm condition on the detector. **Failure to do so may result in sickness or death.**

---

The final alarm is determined by the configuration of the control panel, with the detector only switching its relay to actuate the panel. Do not connect the detector to Fire Alarm Circuits, or Burglar Alarm or other signals. The illumination of the red (ALARM) light on the detector indicates the alarm condition. When an alarm occurs immediately evacuate the premises and seek assistance.

### WARNING

This detector will only indicate the presence of combustible gas at the sensor. Combustible gas may be present in other areas. Accommodation spaces should be well ventilated when household cleaning supplies or similar contaminants are used.

---

In addition to the hydrogen gas that it is designed to detect, the detector can also be affected by a broad range of combustible gases. Some of these that may cause an alarm are: alcohol, ammonia, cleaning solvents, paint thinner, gasoline vapors, and aerosol propellants. Aerosol cans such as hair spray usually contain a combustible gas. Always make sure that there is adequate ventilation when you use these products. Proper location will minimize alarms due to normal use of household products.

## TROUBLE INDICATOR

The trouble signal is determined mostly by the configuration of the alarm panel, with the detector trouble relay only providing an open circuit for actuation. A failure of the gas-sensing element will result in both lights turning on and off and the trouble relay opening. Failure of power supplies in the detector or a lack of power to the detector will result in the trouble relay opening. The most common expected trouble would be a break in the wiring between the panel and the ENVIROMUX-H2. When a trouble signal occurs call the alarm panel installer for assistance.

### WARNING

Do not cover or obstruct visual alarm LED. Doing so may adversely affect product performance and **result in sickness or death.**

---

## MAINTENANCE

The ENVIROMUX-H2 does not require regular maintenance. The unit uses a self-purging semi-conductor sensor that has a long life expectancy. All service and repair of the detector are to be performed by NTI. NTI does not sanction any third-party repair facilities.

### WARNING

Do not disassemble unit or attempt to repair or modify any component of this instrument. This instrument contains no user serviceable parts, and substitution of components may impair intrinsic safety which may adversely affect product performance and **result in sickness or death.**

---

## TESTING

Once the unit is fully operational (the green light is on steady), test the unit by directing gas from an unlit butane cigarette lighter into the sensor near the green light on the left hand side. It will be necessary to hold the lighter valve open for 2 to 3 seconds. The red light (ALARM) will turn on, the alarm relay switches, and any devices connected should activate. The detector should be tested regularly by using gas from an unlit cigarette lighter, as detailed above.

## CLEANING

The detector should be cleaned using the soft brush attachment of your vacuum cleaner. The detector should be tested after cleaning to ensure the unit is operating normally.

## SENSOR POISONS

The gas-sensing tip in the detector is designed with extreme sensitivity to the environment. As a result, the sensing function of the tip may deteriorate if it is exposed to a direct spray from aerosols such as paints, silicone vapors, etc., or to a high density of corrosive gases (such as hydrogen sulfide, sulfur dioxide) for an extended period of time.

## WIRING METHODS

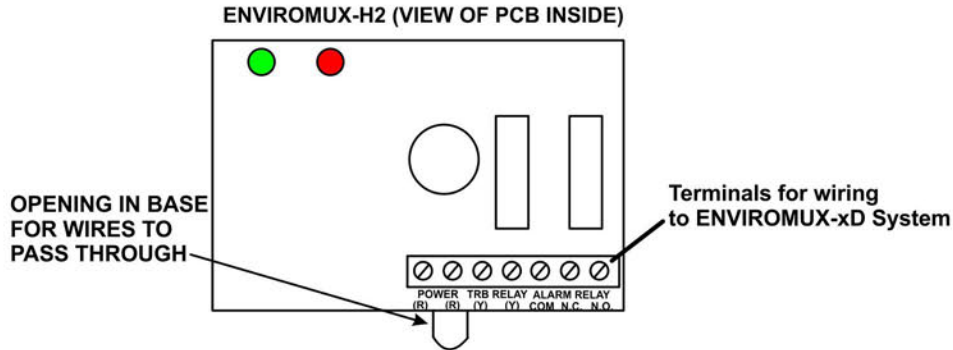

**Schematic for wiring Hydrogen Gas Detector to ENVIROMUX SYSTEM**

### FOR ENVIROMUX-16D

**VIEW OF TERMINALS ON ENVIROMUX-16D**

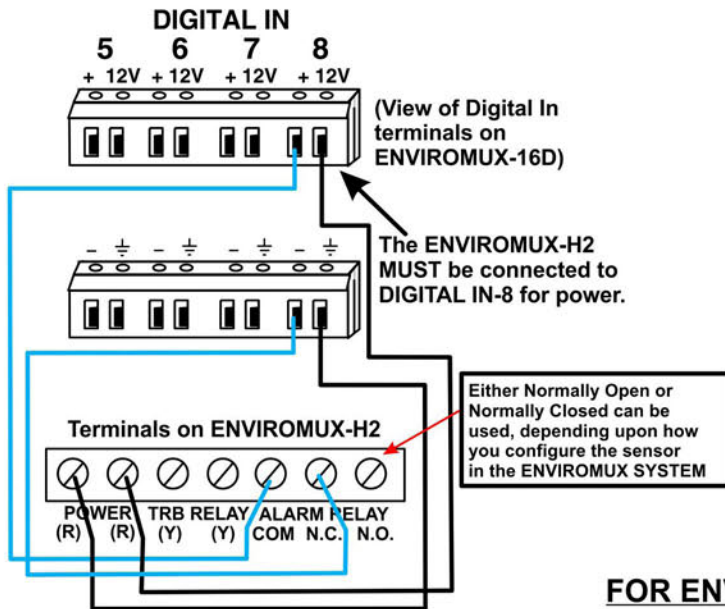

### FOR ENVIROMUX-5D

**VIEW OF TERMINALS ON ENVIROMUX-5D**

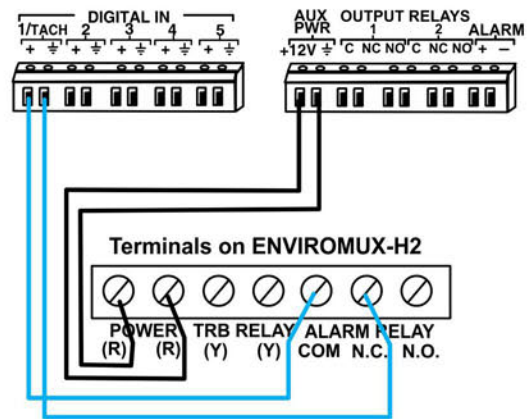

### FOR ENVIROMUX-2D

**VIEW OF TERMINALS ON ENVIROMUX-2D**

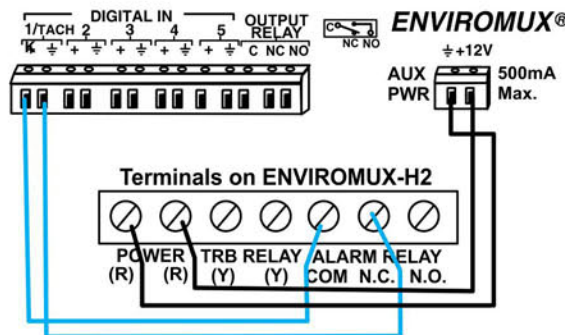

If AUX PWR capacity is in use, an external 12VDC power supply is available from NTI.

**To configure the ENVIROMUX-H2 in the ENVIROMUX-xD System, follow the instruction for configuring Contact Sensors found in the ENVIROMUX-xD manual.**