

Kramer Electronics, Ltd.



USER MANUAL

Models:

610T, Detachable Optical DVI Transmitter

610R, Detachable Optical DVI Receiver

Contents

1	Introduction	1
2	Getting Started	1
3	Overview	2
3.1	Powering the 610T and the 610R	3
4	Your Detachable Optical DVI Transmitter/ Receiver	4
5	Using the Detachable Optical DVI System	4
5.1	The Display Device EDID	4
5.1.1	Defining EDID	5
5.1.2	Capturing the Virtual EDID	5
5.2	Connecting the Detachable Optical DVI Transmitter/Receiver	6
5.3	Avoiding Pitfalls using the 610T and 610R	7
6	Technical Specifications	8

Figures

Figure 1:	610 Detachable Optical DVI Transmitter and Receiver	4
Figure 2:	The Auto EDID Button on the 610T	5
Figure 3:	Connecting the Fiber Optic Cables	6
Figure 4:	Connecting the 610T/610R Detachable Optical DVI Transmitter/Receiver	7

Tables

Table 1:	Technical Specifications of the 610T/610R	8
----------	---	---

1 Introduction

Welcome to Kramer Electronics! Since 1981, Kramer Electronics has been providing a world of unique, creative, and affordable solutions to the vast range of problems that confront the video, audio, presentation, and broadcasting professional on a daily basis. In recent years, we have redesigned and upgraded most of our line, making the best even better! Our 1,000-plus different models now appear in 11 groups¹ that are clearly defined by function.

Congratulations on purchasing your Kramer **610T Detachable Optical DVI Transmitter** and **610R Detachable Optical DVI Receiver**, which are ideal for:

- Digital flat panel displays, plasma display panels and projectors for medical appliances, aero and traffic control, factory facilities, banks, conference rooms and auditoriums
- Kiosks with digital flat panel displays for information display
- LED signboards in streets and in stadiums
- Digital Signage

The package includes the following items:

- **610T Detachable Optical DVI** and/or **610R Detachable Optical DVI**
- 2 Power adapters (5V DC Input) and this user manual²

2 Getting Started

We recommend that you:

- Unpack the equipment carefully and save the original box and packaging materials for possible future shipment
- Review the contents of this user manual
- Use Kramer high performance high resolution cables³

¹ GROUP 1: Distribution Amplifiers; GROUP 2: Switchers and Matrix Switchers; GROUP 3: Control Systems; GROUP 4: Format/Standards Converters; GROUP 5: Range Extenders and Repeaters; GROUP 6: Specialty AV Products; GROUP 7: Scan Converters and Scalers; GROUP 8: Cables and Connectors; GROUP 9: Room Connectivity; GROUP 10: Accessories and Rack Adapters; GROUP 11: Sierra Products

² Download up-to-date Kramer user manuals from the Internet at <http://www.kramerelectronics.com>

³ The complete list of Kramer cables is on our Web site at <http://www.kramerelectronics.com>

3 Overview

The high performance Kramer **610T** and **610R** have a transmission range of up to 1640 ft. (500 meters) of single link high-resolution digital graphic data over four fiber optic cables¹ with LC connectors. The **610T** converts electrical signals to optical signals and the **610R** decodes the optical signals back to electrical signals. The transmitter can read the display device's EDID², and once it is connected to the computer, it provides this data³.

In particular, the **610T/610R** pair:

- Is EMI/RFI cable free
- Provides a single-link DVI-D connection⁴
- Supports DVI1.0 and DDC2B, fully implemented by fiber-optic communication
- Supports resolutions exceeding WUXGA at 60Hz or 1.65Gbps bandwidth per graphic channel
- Transmits one red, one green and one blue channel, and one clock with a 1 pixel/clock mode – over the fiber optic cables, with 2 duplex LC fiber connectors
- Complies with the limits for a Class A digital device, pursuant to part 15 and 2 of FCC and CE
- Does not require any special memory size, CPU speed and chipsets, when using a computer

1 Multi-mode glass fiber cables with LC connections must be used

2 Extended Display Identification Data

3 See section 5.1

4 With no HDCP support

To achieve the best performance:

- Connect only good quality connection cables, thus avoiding interference, deterioration in signal quality due to poor matching, and elevated noise-levels (often associated with low quality cables)
- Avoid interference from neighboring electrical appliances and position your Kramer **610R** and **610T** away from moisture, excessive sunlight and dust



Caution – No operator-serviceable parts inside unit.

Warning – Use only the Kramer Electronics input power wall adapter that is provided with this unit¹.

Warning – Disconnect power and unplug unit from wall before installing or removing device or servicing unit.

3.1 Powering the 610T and the 610R

The Kramer **610T** can be powered either by an external power adapter or internally by the 5V pin on the DVI card of the computer. The **610T** automatically detects if it is being powered via the external power adapter, and if so, the internal power supply will be cut off.

The **610R** module must always be powered by the power adapter.

Most laptops require that the external power adapter is used for the transmitter.

¹ For example, part number 2535-052002

4 Your Detachable Optical DVI Transmitter/ Receiver

Figure 1 illustrates the **610T** and **610R** optical DVI extension system:

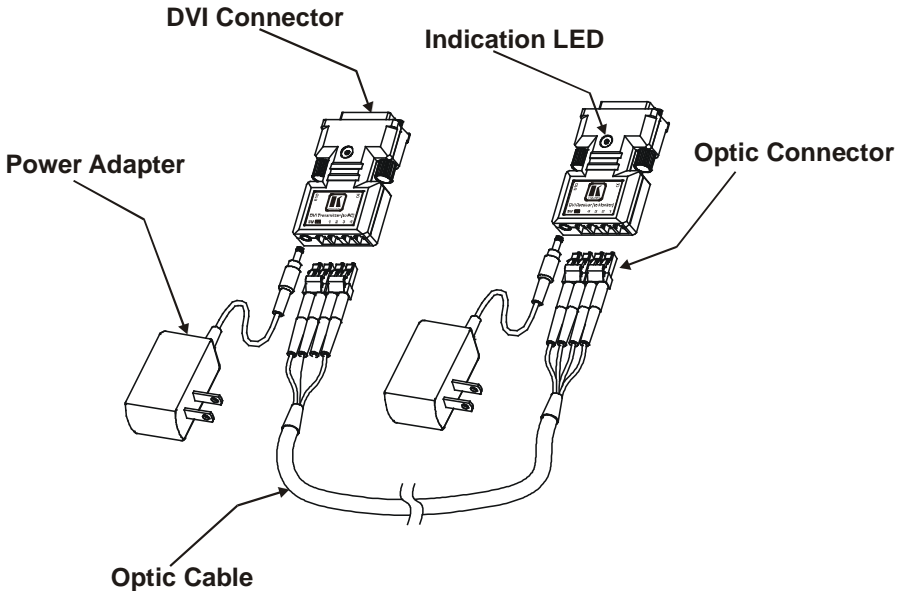

Figure 1: 610 Detachable Optical DVI Transmitter and Receiver

5 Using the Detachable Optical DVI System

This section describes how to:

- Capture the EDID of the display device
- Connect the detachable optical DVI transmitter and receiver

5.1 The Display Device EDID

The **610T** and **610R** are connected via four channels that transmit R, G, B and clock signals. The EDID of the display device is captured onto the transmitter for the computer to read.

5.1.1 Defining EDID

The Extended Display Identification Data (EDID¹) is a data-structure, provided by a display, to describe its capabilities to the DVI graphics source (for example, the graphics card of the computer). The EDID enables the computer to “know” what kind of monitor is connected to the output. The EDID includes the manufacturer’s name, the product type, the phosphor or filter type, the timing data supported by the display, the display size, luminance data and, for digital displays only, the pixel mapping data.

5.1.2 Capturing the Virtual EDID

You can capture the EDID of the display device on the **610T** so that when the computer connects to the **610T**, it will read the virtual EDID information and identify the display device. This procedure is performed only once for the connected display device. After storing the EDID, the system can be connected and disconnected without having to set the EDID again. If the display device is replaced, the new EDID should be set on the **610T** transmitter.

To capture the EDID of a display device, do the following:

1. Connect the 5V power adapter to the power socket of the **610T**, and connect the adapter to the mains electricity.
The Indication LED lights.
2. Push the Auto EDID button (illustrated in Figure 2), using a thin screwdriver.
3. Connect the **610T** unit **directly** to the display device.
The Indication LED blinks several times while reading the EDID.
4. When the Indication LED stops blinking, disconnect the power.
5. Disconnect the **610T**.
The EDID information is now stored and the Indication LED is on.

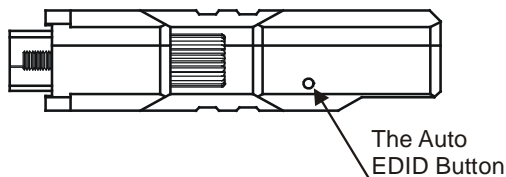

Figure 2: The Auto EDID Button on the 610T

¹ EDID is defined by a standard published by the Video Electronics Standards Association (VESA)

5.2 Connecting the Detachable Optical DVI Transmitter/Receiver

To connect the **610T Detachable Optical DVI Transmitter** with the **610R Detachable Optical DVI Receiver**, as the example in Figure 4 illustrates, do the following:

1. Set the EDID of the display device (see section 5.1).
2. Plug the **610T** DVI connector **directly**¹ to the DVI connector of the computer.
3. Connect the **610R** to the 5V DC power adapter and connect the adapter to the mains electricity. The Indication LED is on.
4. Connect the **610R** DVI connector **directly**¹ to the DVI connector of the display device.
5. Connect the duplex LC fiber cables² to the **610T** and **610R** modules, one cable at a time, as illustrated in Figure 3.

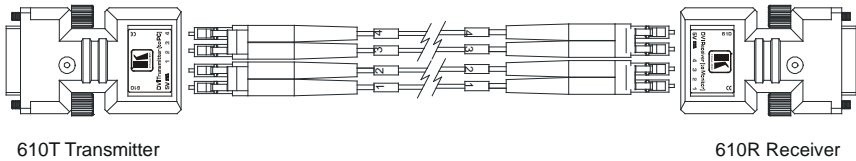

Figure 3: Connecting the Fiber Optic Cables

6. Turn ON the Power on the computer and the display device.
7. If the transmitter does not power up, connect the 5V power adapter³ to the **610T** transmitter, and connect the adapter to the mains electricity.
8. Set up the screen resolution as required.

¹ Do not use any intermediate cable or adapter between them

² Two duplex LC receptacles connected to two duplex LC patch cord multimode glass of fibers with a 62.5/125µm or a 50/125µm core

³ You can use the power supplied through a DVI pin from the graphic cards instead of using the power adapter. After completing the installation, if the system does not seem to work properly, reconnect the power adapter while the system is powered

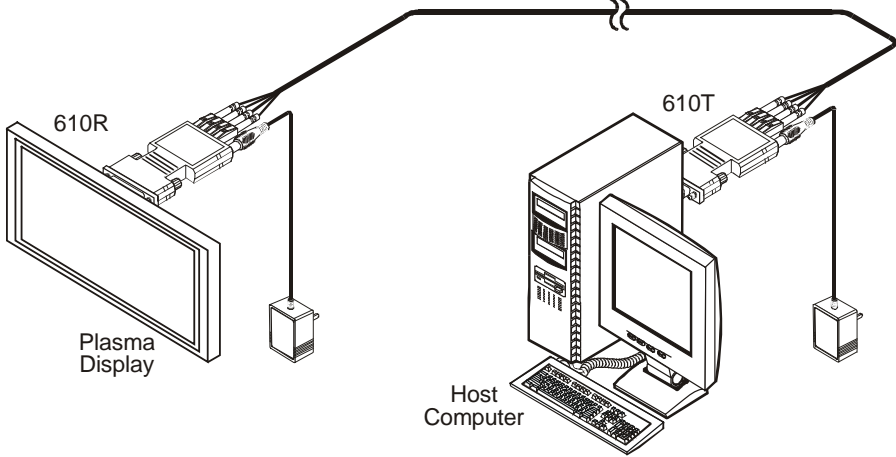

Figure 4: Connecting the 610T/610R Detachable Optical DVI Transmitter/Receiver

5.3 Avoiding Pitfalls using the 610T and 610R

In the event that any of these problems occur, we recommend the following:

If the display device shows only a black screen:

- Make sure that all the AC and DC plugs and jacks used by the external power supplies are firmly connected
- Be sure that the DVI ports are firmly plugged into the computer and the display device, and be sure that the Transmitter and Receiver modules are correctly plugged into the computer and display device, respectively
- Check if the computer and display are powered ON and properly booted
- Reset the system by unplugging and then replugging the Transmitter DVI port or Receiver DVI port and then reboot the system

If the screen is distorted or displays noise:

- Check if the graphics resolution is properly set
- Go to the Display Properties of Windows and check the settings
- Be sure that the resolution is set for WUXGA (1,920 x 1,200) at 60Hz, or lower
- Reset the system
- Disconnect and reconnect the optical DVI cables

Be sure that at all times the cables are stored and used away from liquid or dirt

6 Technical Specifications

Table 1 includes the technical specifications:

Table 1: Technical Specifications¹ of the 610T/610R

INPUTS:	DVI IN (610T), 4 LC optical connectors (610R)
OUTPUTS:	4 LC optical connectors (610T), DVI OUT (610R)
RESOLUTION:	Up to WUXGA @60Hz (1.65Gbps)
POWER SOURCE:	5V DC, <500mA
DIMENSIONS:	3.8cm x 7.2cm x 1.9cm (1.5" x 2.83" x 0.75") W, D, H
WEIGHT:	0.14kg (0.31lbs) approx.
ACCESSORIES:	2 power supplies

¹ Specifications are subject to change without notice. For details of the operating and storage temperature ranges, see the General Operating Conditions on our Web site at <http://www.kramerelectronics.com>

LIMITED WARRANTY

Kramer Electronics (hereafter *Kramer*) warrants this product free from defects in material and workmanship under the following terms.

HOW LONG IS THE WARRANTY

Labor and parts are warranted for one year from the date of the first customer purchase.

WHO IS PROTECTED?

Only the first purchase customer may enforce this warranty.

WHAT IS COVERED AND WHAT IS NOT COVERED

Except as below, this warranty covers all defects in material or workmanship in this product. The following are not covered by the warranty:

1. Any product which is not distributed by Kramer, or which is not purchased from an authorized Kramer dealer. If you are uncertain as to whether a dealer is authorized, please contact Kramer at one of the agents listed in the Web site www.kramerelectronics.com.
2. Any product, on which the serial number has been defaced, modified or removed, or on which the WARRANTY VOID IF TAMPERED sticker has been torn, reattached, removed or otherwise interfered with.
3. Damage, deterioration or malfunction resulting from:
 - i) Accident, misuse, abuse, neglect, fire, water, lightning or other acts of nature
 - ii) Product modification, or failure to follow instructions supplied with the product
 - iii) Repair or attempted repair by anyone not authorized by Kramer
 - iv) Any shipment of the product (claims must be presented to the carrier)
 - v) Removal or installation of the product
 - vi) Any other cause, which does not relate to a product defect
 - vii) Cartons, equipment enclosures, cables or accessories used in conjunction with the product

WHAT WE WILL PAY FOR AND WHAT WE WILL NOT PAY FOR

We will pay labor and material expenses for covered items. We will not pay for the following:

1. Removal or installations charges.
2. Costs of initial technical adjustments (set-up), including adjustment of user controls or programming. These costs are the responsibility of the Kramer dealer from whom the product was purchased.
3. Shipping charges.

HOW YOU CAN GET WARRANTY SERVICE

1. To obtain service on your product, you must take or ship it prepaid to any authorized Kramer service center.
2. Whenever warranty service is required, the original dated invoice (or a copy) must be presented as proof of warranty coverage, and should be included in any shipment of the product. Please also include in any mailing a contact name, company, address, and a description of the problem(s).
3. For the name of the nearest Kramer authorized service center, consult your authorized dealer.

LIMITATION OF IMPLIED WARRANTIES

All implied warranties, including warranties of merchantability and fitness for a particular purpose, are limited in duration to the length of this warranty.

EXCLUSION OF DAMAGES

The liability of Kramer for any effective products is limited to the repair or replacement of the product at our option. Kramer shall not be liable for:

1. Damage to other property caused by defects in this product, damages based upon inconvenience, loss of use of the product, loss of time, commercial loss; or:
2. Any other damages, whether incidental, consequential or otherwise. Some countries may not allow limitations on how long an implied warranty lasts and/or do not allow the exclusion or limitation of incidental or consequential damages, so the above limitations and exclusions may not apply to you.

This warranty gives you specific legal rights, and you may also have other rights, which vary from place to place.

NOTE: All products returned to Kramer for service must have prior approval. This may be obtained from your dealer.

This equipment has been tested to determine compliance with the requirements of:

- EN-50081: "Electromagnetic compatibility (EMC);
generic emission standard.
Part 1: Residential, commercial and light industry"
- EN-50082: "Electromagnetic compatibility (EMC) generic immunity standard.
Part 1: Residential, commercial and light industry environment".
- CFR-47: FCC* Rules and Regulations:
Part 15: "Radio frequency devices
Subpart B Unintentional radiators"

CAUTION!

- Servicing the machines can only be done by an authorized Kramer technician. Any user who makes changes or modifications to the unit without the expressed approval of the manufacturer will void user authority to operate the equipment.
- Use the supplied DC power supply to feed power to the machine.
- Please use recommended interconnection cables to connect the machine to other components.
* FCC and CE approved using STP cable (for twisted pair products)



For the latest information on our products and a list of Kramer distributors, visit our Web site: www.kramerelectronics.com, where updates to this user manual may be found. We welcome your questions, comments and feedback.



Caution

Safety Warning:

Disconnect the unit from the power supply before opening/servicing.



Kramer Electronics, Ltd.

Web site: www.kramerelectronics.com

E-mail: info@kramereel.com

P/N: 2900-000152 REV 5