



Model: WS RETROFIT FOR iPad PRO 10.5" BLACK/WHITE

Model No.: 10-01-796-BL/-WH

Family: WALL-SMART

DWG NO. 10-04-796-SPC

PRODUCT SPEC.

REVISION B

DATE 29/NOV/2018



**Make Your Wall Smart**

**“WS RETROFIT FOR iPad PRO 10.5" BLACK/WHITE” - Product description:**

The “WS RETROFIT FOR iPad PRO 10.5" BLACK/WHITE” is an adapter for in-wall nearly flush retrofit installation of iPad PRO 10.5".

The “WS RETROFIT FOR iPad PRO 10.5" BLACK/WHITE” firmly mounts the iPad PRO 10.5" while allowing easy insertion, removal and operation.

**Key features and benefits:**

- Nearly flush with the wall (4mm [0.16"] thick on-wall bezel).
- Wall mount may be mounted in any orientation.
- Wall mount contains depth calibration screws.
- Designed for the use with iPad PRO 10.5" (by Apple) (iPad is not included).
- Adapter kit contains:
  1. (X1) Wall adapter;
  2. (X2) Wall-Smart rubber pads;
  3. (X1) Wall-Smart Pad Positioning Template;
  4. (X1) Bezel;
- The bezel is supplied painted black (-BL) or white (-WH). The bezel may be custom ordered without paint (-WO)
- The bezel is supplied, by default, with speaker and mic grills. The bezel may be custom ordered without audio grills (add suffix -NG to the part number)

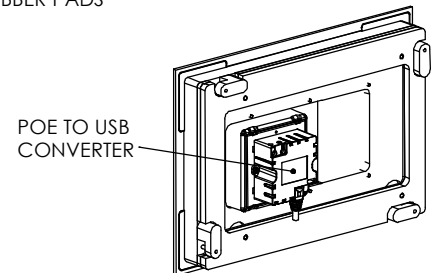
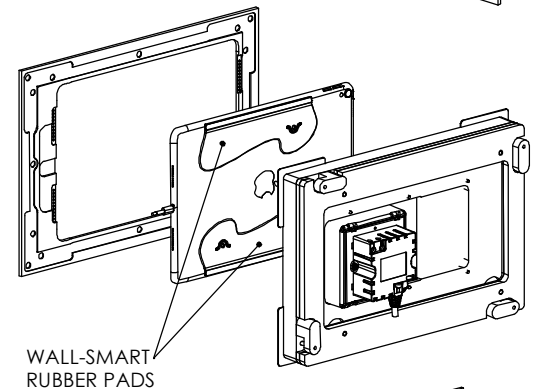
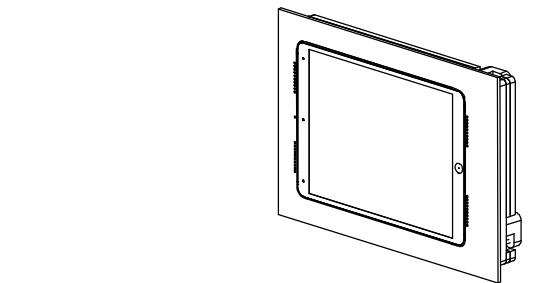
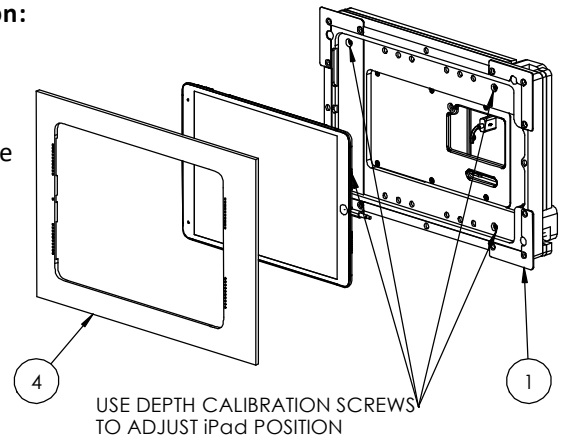

**Key properties:**

- Dimensions: (W/H/D): 327.1mm (12.88")/ 229.3mm (9.03")/ 79.1mm (3.12")
- Power Supply: Wall mount includes POE to USB converter. The installer should connect the wall mount to an IEEE 802.3at POE+ power source via CAT6 cable and RJ45 connector. (Please verify the power source can supply up to 25.5W)
- Weight: 2.8Kg, 6.16lbs.
- Material: Moisture resistant MDF

iPad® is a trademark of Apple Inc., registered in the U.S. and other countries.

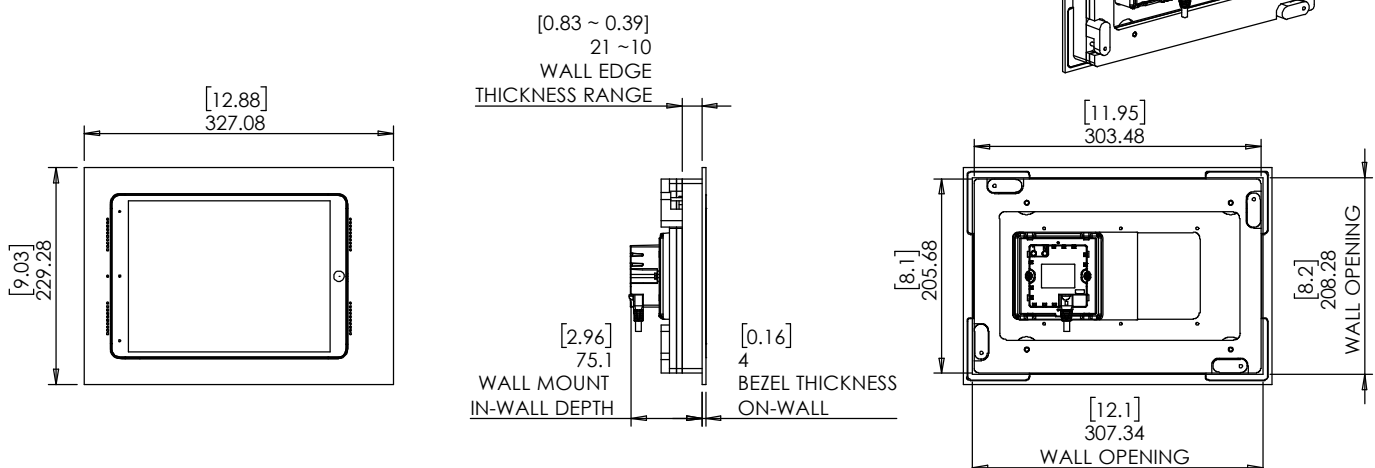



Model: WS RETROFIT FOR iPad PRO 10.5" BLACK/WHITE

Family: WALL-SMART

DWG NO. 10-04-796-SPC

Model No.: 10-01-796-BL/-WH

PRODUCT SPEC.

REVISION B

DATE 29/NOV/2018



### Wall-Smart rubber pads installation:

1. Clean iPads back surface.
2. Position template.

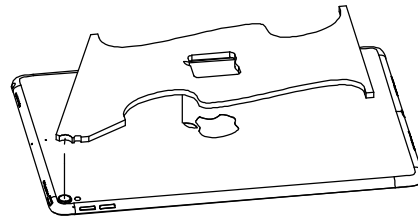

3. Align template cutouts with Apple logo and cam lens housing.

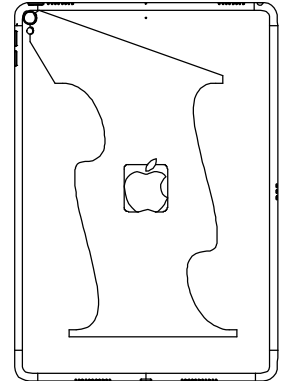

4. Remove protective tape of a rubber pad back adhesive.
5. Align rubber pad to template while maintaining the position of the template.
6. Adhere the rubber pad to the iPad gradually from template to the iPad edge.

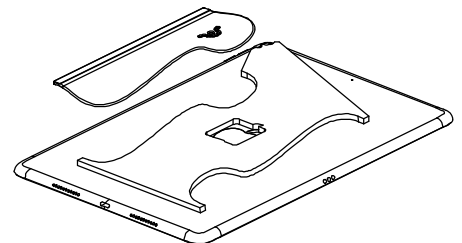

7. Press down from the center of the rubber pad and towards the pad edges to remove air bubbles.
8. Push down the edges of the rubber pad to close all gaps.
9. Repeat steps 4-8 for the second rubber pad.
10. Remove the template and wait 6mins before mounting.

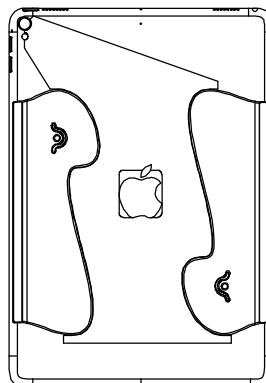
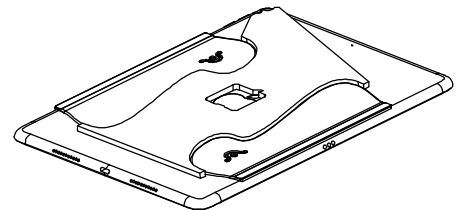



WS RETROFIT FOR  
Model: iPad PRO 10.5" BLACK/WHITE

Family: WALL-SMART

DWG NO. 10-04-796-SPC



Model No.: 10-01-796-BL/-WH

PRODUCT SPEC.

REVISION B

DATE 29/NOV/2018

